

dSPACE NEWS

FACTS · PROJECTS · EVENTS

Customers

Audi – Songs from
the Simulator

Products

AutomationDesk 2.0 –
Develop Tests More
Efficiently

**Kässbohrer –
MicroAutoBox Pulls 9-Tonner**

A red PistenBully 6120 snowcat is shown driving through deep snow in a mountainous, snowy landscape. The snowcat is equipped with a large front-mounted blade and has the number '6120 PistenBully' visible on its side. The background features snow-covered mountains and a clear sky.

Editorial

- 3** By Dr. Herbert Hanselmann
President

Customers

- 4** Audi: Infotainment HIL Simulator
- 6** Delphi: Audio Playback
Control Development
- 8** Airbus Germany: The Pressure on Planes
- 10** TU München: Optimized CVT Hybrid
- 12** Universität Graz: ABS Test Bench
for Teaching and Research
- 14** Piaggio: HIL for a Three-Wheeler
Scooter
- 16** Ohio State University: Control of
Hybrid-Electric SUV
- 18** ZF Lenksysteme: Efficient Test Processes
- 20** Eurocopter Germany: Comfort Mode
for Helicopters
- 22** Kässbohrer: Snow Cat on a Hook
- 24** Mitsubishi: Virtual Outlander
- 27** DAF: Keeping the Right Speed

Products

- 28** AutomationDesk is 2.0!
- 30** Generating Test Cases Automatically
(TargetLink/EmbeddedTester)
- 32** Hand in Hand (SystemDesk / TargetLink)

Business

- 34** 5th German User Conference
- 36** 2nd Japanese User Conference
- 37** Reader Survey
- 37** dSPACE Inc. Keeps Growing
- 38** Compact News
- 39** Info and Dates

dSPACE NEWS

dSPACE NEWS is published periodically by:

dSPACE GmbH · Technologiepark 25
33100 Paderborn · Germany
Tel.: +49 52 51 16 38-0 · Fax: +49 52 51 6 65 29
dspace-news@dspace.de · info@dspace.de
support@dspace.de · www.dspace.com

Project Manager and Author: André Klein
Technical Authors: Alicia Alvin, Bettina Henking-Stuwe,
Ralf Lieberwirth, Sonja Lillwitz, Julia Reinbach,
Dr. Gerhard Reiß, Klaus Schreiber
Editors and Translators: Robert Bevington, Stefanie Bock,
Michelle Kloppenburg, Christine Smith
Layout: Beate Eckert, Tanja Raeisi, Sabine Stephan

© Copyright 2007
All rights reserved. Written permission is required for
reproduction of all or parts of this publication.
The source must be stated in any such reproduction.
This publication and the contents hereof are subject to
change without notice.
Brand names or product names are trademarks or registered
trademarks of their respective companies and organizations.

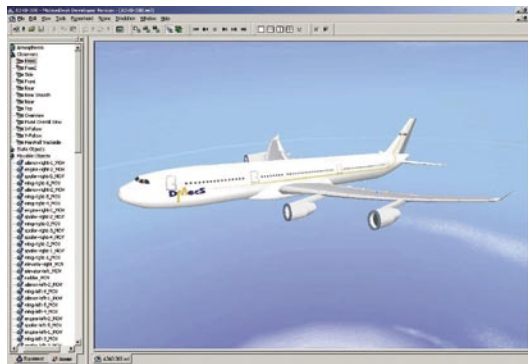

8 To determine the structural loads on aircraft during flight, Airbus and DMecS developed a parallel aircraft model and tested it with a dSPACE real-time system, including two DS1006s.



14 With its two front wheels, Piaggio's MP3 runs very stably even at tight angles. The electronic control unit (ECU) network was tested with a hardware-in-the-loop (HIL) simulator from dSPACE.



The heat is on! The automotive industry is investing heavily in software and electronics, and since OEMs either do not have enough internal resources themselves, or do not want to take on more, they delegate tasks to suppliers and service

providers, who also have their hands full. We too, as tool manufacturers, are noticing an upsurge in the area of embedded electronic development and test. Rapid control prototyping (RCP), hardware-in-the-loop simulation (HIL), or production code generation with TargetLink, demand for all of this is increasing. With RCP, our customers are performing an enormous number of new and expanded developments. With HIL, we see the necessity of rigorous testing. And with TargetLink, it is the growth of model-based design.

The need to invest heavily in more rigorous, efficient and effective testing has been clear to some European auto manufacturers for a long time – especially to those utilizing significant amounts of electronics and software. HIL has long since advanced from an optional instrument for boosting productivity to a vital instrument for quality assurance. Even large “virtual vehicle” HIL simulators for entire vehicles or major vehicle sections are built at dSPACE in such numbers now that it almost makes me think of an assembly line, if they weren’t so customer-specific.

Even so, virtual vehicles are not yet common practice everywhere. The USA and Japan started showing interest only over the last two years, so it is still early days for this technology in those countries. The speed with which the Japanese are embracing the technology is amazing. It started taking off there in 2005/2006, around the time when we set up our Japanese subsidiary. Since then, several projects have been completed or are underway. This is just one of the reasons why, our Japanese subsidiary has already doubled its office and laboratory space in less than two years.

What is also amazing is the openness of one of our Japanese virtual vehicle customers. When did you ever get to peek inside a Japanese laboratory? Take a look at page 24! A major factor in the success of this HIL project was the openness and trust between Mitsubishi and ourselves in our role as the HIL system manufacturer.

We know precisely what information we need and why. If a customer is unable to provide the necessary information early enough, the result is a loss in efficiency, reliability, performance and then satisfaction both for the customer and us. To put together a virtual vehicle and get it up and running, we need a good idea of the overall system. This is the only way we can understand how things interact and put the simulator into operation fast. After all, the point is to find errors in the vehicle network and not in the simulator.

*Dr. Herbert Hanselmann
President*



16 *The Ohio State University team taking part in Challenge X, the engineering competition, used a dSPACE MicroAutoBox as the primary control for essential functions of the hybrid drive train.*

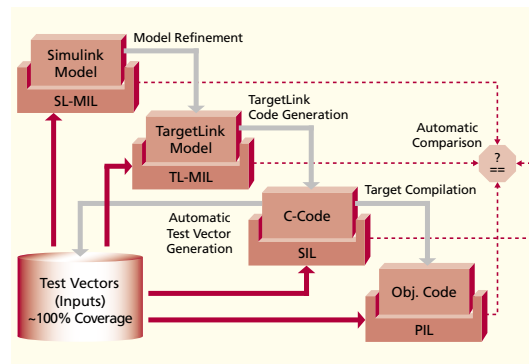

30 *The TargetLink/EmbeddedTester duo gives control engineers an integrated development environment and also enables them to test and validate automatically – thanks to automatically generated test cases.*

Infotainment HIL Simulator at Audi

- ▶ **Testing infotainment networks for Audi's A4/A5 series**
- ▶ **dSPACE Simulator is core of HIL test system**
- ▶ **MOST® bus connection via OptoLyzer**

Car buyers nowadays can expect to find an optimum onboard functionality mix of information, entertainment, and communication, collectively known as infotainment. To test the fault diagnostics capability of networked infotainment components in its A4/A5 series, Audi uses a dSPACE Simulator combined with a MOST® interface (based on SMSC OptoLyzer) and 152 original infotainment components. Using the dSPACE Simulator, Audi can switch back and forth between all the different component configurations, simulate faults, and simulate LIN/CAN ECUs in restbus simulation – with a minimum of configuration work and the highest possible testing speed.

The Infotainment Superbrain

From pure “onboard entertainment” to a major human-machine interface – that’s how the evolution of in-vehicle infotainment systems could be described. For driver and passengers to use the radio, CD, TV, telephone, navigation system and various vehicle settings in the Audi A4/A5, the vehicle has a Multi Media Interface (MMI). This is a central system with an eye-level display and a terminal within easy reach. The infotainment components communicate with one another via the optical MOST bus (Most = Media Oriented Systems Transport). Vehicle data from the CAN bus such as battery status and speed are provided to the gateway ECU via restbus

simulation. Because customers can request different configurations of infotainment components in the same vehicle model, Audi has to test all possible configurations via hardware-in-the-loop (HIL) tests and simulate possible faults. Audi uses a dSPACE Simulator for this, with 152 original infotainment components and a MOST interface implemented by dSPACE (based on SMSC OptoLyzer).

Flexibility with dSPACE Simulator

34 possible MOST nodes are integrated into the dSPACE Simulator-based test environment (central ECU, amplifiers, radios, telephones, navigation systems, CD drives/jukeboxes and vehicle gateway), together

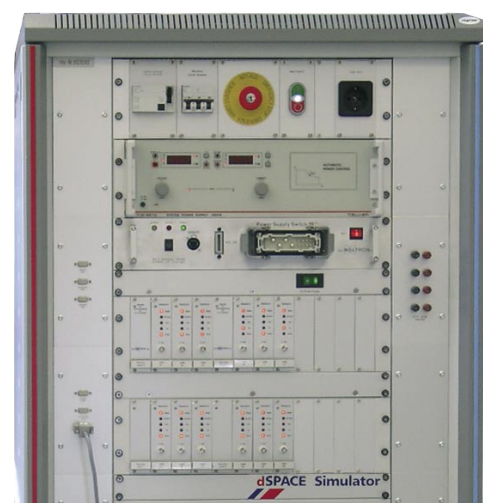
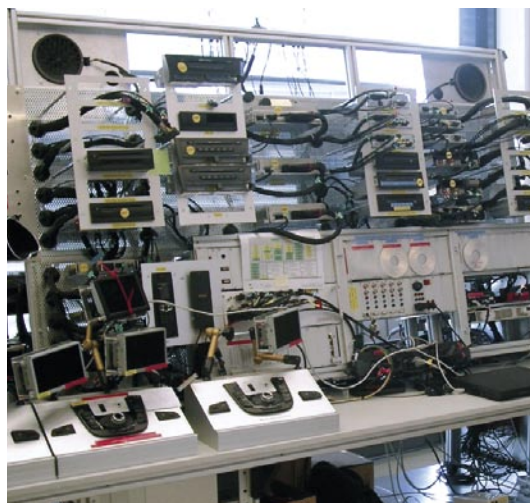

▲ Audi makes quick work of combining and recombining 152 infotainment components to test fault diagnostics. The developers switch component configurations on the dSPACE Simulator in next to no time, simulate fault cases, and perform restbus simulation of LIN/CAN ECUs.

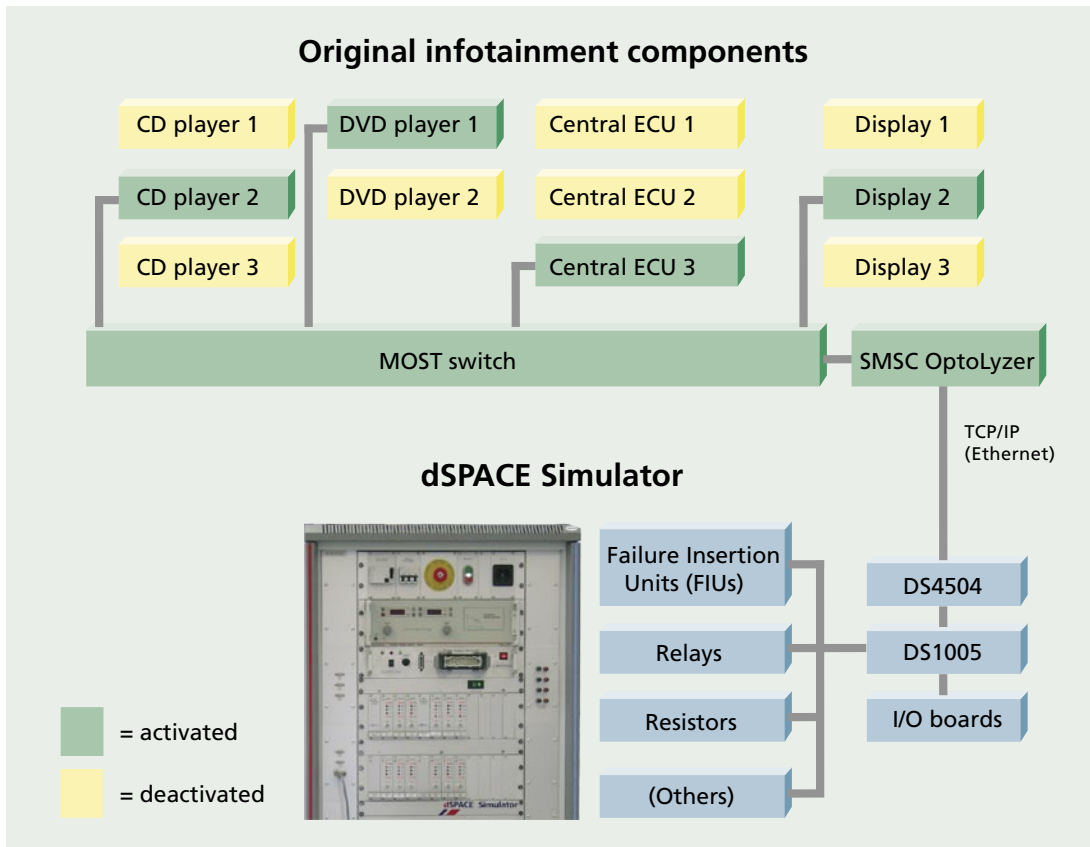

▲ Because it saved so much time, the infotainment HIL system used for the Audi A4/A5 series, based on dSPACE Simulator, will soon be used for other model series as well.

with 82 aerials (such as radio, TV, GSM and GPS) and 36 different types of loudspeakers, and they can all be switched in and out as required. In addition, there are several different terminal/display combinations for the Multi Media Interface. The dSPACE Simulator is based on DS1005 PPC Boards with ControlDesk as the experiment software and uses approx. 600 relays, more than 200 digital outputs, 300 failure insertion

was to give the dSPACE Simulator a MOST interface. dSPACE very quickly created a custom MOST interface for Audi, based on SMSC OptoLyzer (MOST analysis and development platform from SMSC), a dSPACE Ethernet interface board, special Simulink® S-functions, and the DS1005 PPC Boards.

The Future with dSPACE Simulator

It took only 4 months from start of project to get Audi’s infotainment simulator into productive operation, including the test phase and despite the MOST interface having to be implemented from scratch. Formerly, Audi had to perform installation work to change infotainment components. Now the developers can switch between configurations flexibly, so the dSPACE Simulator is in nonstop active use. In the future, the infotainment simulator from dSPACE will be used for other model series in addition to the A4/A5 series.

“Our dSPACE Simulator for testing infotainment networks fulfills our requirements outstandingly: We achieve considerable time savings in both configuring and testing compared with previous processes.”

Markus Ritzer, Audi AG

channels and 32 resistance channels. It enables Audi to perform failure simulation rapidly for all configurations and on almost all pins. Examples of faults are a break in the MOST ring caused by the failure of a MOST node (every node can receive and send) and a weak battery. Audi can simulate LIN/CAN ECUs on the dSPACE Simulator as the restbus. An initial challenge

*Markus Ritzer
 Audi AG
 Ingolstadt, Germany*



Audio Playback Control Development

- Model-based audio playback development at Delphi
- Stateflow logics for behavior, error handling, and communication
- Efficient production code generation with TargetLink

Audio playbacks are mechanisms that read data from a storage medium, such as CD digital audio, CD-R or MP3 disc, and produce commands and signals that an audio system turns into music. Playbacks are constantly changed to meet market demands, requiring the control software to be updated quickly and efficiently. A development team at Delphi demonstrated working units running production-ready code within 12 months by using model-based design and automatic production code generation with TargetLink from dSPACE.

A modern radio is constructed of building blocks, such as the AM/FM tuner, the human-machine interface (HMI), communications, the playback mechanism, and so forth. The various building blocks are run as tasks, controlled by the operating system (OS). The OS calls these tasks, based on assigned priorities and interdependencies triggered either internally or in response to button-presses or media insertions on the radio faceplate. Audio playback mechanisms (“playbacks”) are typically the most complex building block in a radio. Aggressive price-cutting by playback vendors and a steady flow of new functions

and requirements all drive rapid change. To handle changes of such complex products, radio suppliers must accelerate software development, testing, and implementation for playbacks. Modular design within a universal architecture is a design goal, using customizable building blocks from a reuse library.

Special Challenges

The interface between the main board and the playback is typically a low-end microprocessor sending and receiving digital communications messages in two directions using a protocol such as Inter Integrated Circuit (I²C). Despite communication standards, playbacks vary in their implementation of I²C or other protocols – a problem usually related to the low level drivers. A further difficulty is the fact that not all digital audio CDs follow the Red Book industry standard, since numerous widely available CD burning programs do not comply. If every CD followed the standards and never received a scratch, if every playback worked perfectly, and if no driver allowed their children to insert hotel keycards into their car radios, playback control would be a straightforward task.

Behavior Modeling

Playbacks execute typical commands known to all users of modern audio devices, such as: load, eject, play, stop/pause, scan, fast forward/reverse, seek up/down (track and/or folder), and options such as shuffle. The functionalities which are evoked in response to these commands are called behaviors. The logic for behaviors, error behavior and communications is captured in Stateflow® Interfaces, and control signals are captured in Simulink®.



▲ Example of a modern navigation radio consisting of several building blocks.

Efficient Code Generation Process

Upon completion of unit testing, we used the production code generator TargetLink to automatically generate ANSI compliant C code. A data dictionary, developed in-house at Delphi, was employed to capture engineering variable characteristics and to map software variables to hardware I/O. TargetLink provides automated documentation in HTML format, which facilitates reading and review of the generated code.

“Using TargetLink, code was generated and tested in just a fraction of the time that is typically required for hand-code implementation of the same algorithm.”

Lev Vitkin, Delphi Electronics & Safety

A comparison of bytes for hand-code (14903 bytes) versus automatically generated code (12437 bytes) shows an improvement of about 17%.

Lessons Learned

Near the project endpoint, a new playback unit was being considered. As a test case, we adapted the interfaces to the new unit in only four hours. This demonstrates the considerable time savings possible with a modular architecture, reusable building blocks and customizable, adaptive interfaces.

Benefits

We found that the visual nature of the architecture made it accessible to high-level managers and less-technical supervisors, as well as facilitated technical discussions amongst our team. We found legacy code easy to integrate with either Stateflow or TargetLink. Code was generated and tested in just a fraction of the time that is typically required for hand-code implementation of the same algorithm.

*Peter J. Schubert,
Packer Engineering, Inc., USA
Lev Vitkin,
Delphi Electronics & Safety, USA
David Braun,
Purdue University, USA*



▲ Radio user interface for virtual control.

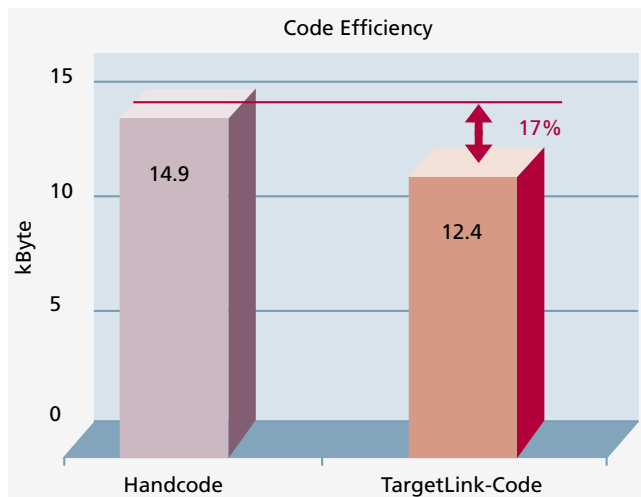

▲ Comparison between handcoded software and code generated with TargetLink for identical function models.

Glossary

Red Book –

The standard for audio CDs is defined in the Red Book. It is named after one of a set of color-bound books that contain the technical specifications for all CD and CD-ROM formats. It was ratified as IEC 908.

Inter Integrated Circuit (I²C) –

A multi-master serial computer bus that is used to attach low-speed peripherals to devices like a motherboard or embedded system.

Reference:
Model-based Development for Event-driven Applications using MATLAB: Audio Playback Case Study, SAE World Congress 2007, paper 2007-01-0783

Test of Strength in the Sky

- **Determining structural loads during flight**
- **Avoiding unnecessary aircraft inspections**
- **Multiprocessor environment of DS1006 Processor Boards**

Due to flight maneuvers and gusts, loads are acting on an aircraft structure during the flight. Severe gusts can result in high structural loads, so that when damages are suspected, the aircraft has to be grounded and a mandatory inspection has to be carried out. To monitor the structural loads during flight, Airbus Germany and DMecS GmbH developed an "observer" – a parallel model of the aircraft – which was tested onboard an A340 using dSPACE equipment.

Avoiding Expensive Grounding Time

To avoid unnecessary inspection and grounding time, we aim to monitor structural loads at any time during operation of an aircraft. Since the loads cannot be measured simultaneously for all locations of the aircraft structure, we have to reconstruct the loads from control surface deflections and the flight data (acceleration, air speed, body rates, Euler angles, etc.) available onboard a passenger aircraft by using a model of the aircraft. In addition, estimates of the gust velocities that impact the aircraft are needed to determine the loads caused by gusts.

The Observer – A Model of the Aircraft

To determine the structural loads caused by gusts, an observer was developed in a joint project by Airbus Germany (Airbus Deutschland GmbH); Department EGLG23, Hamburg; and DMecS Development of Mechatronik Systems GmbH & Co. KG, Cologne. The

observer is a parallel model of the aircraft that is driven by the control surface deflections and corrected via measurements of the resulting aircraft motion. An extension to the aircraft model in the observer accounts for the unknown gust velocities in the observation process. The observer output comprises the estimates of gust velocities and the resulting structural loads due to maneuvers and gusts.

"The dSPACE development environment was an indispensable tool for carrying out the flight tests."

Lars Bensch, Airbus Deutschland

The basis for the observer design is a nonlinear aircraft model developed by Airbus Germany. It takes into account the flexible structure of large, modern passenger aircraft and allows the internal loads at any desired point on the structure to be calculated.

► The observer installed on the dSPACE system receives the control surface deflections and various flight data from the real aircraft and computes the gusts and structural loads.

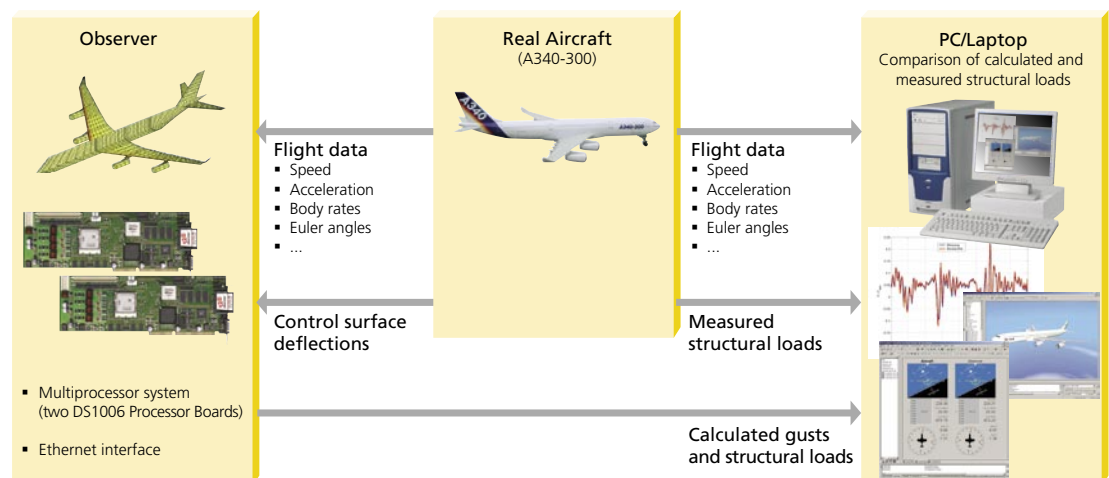

Airbus implemented the model in the VarLOADS (Variable Loads Simulation) environment by means of MATLAB®/Simulink®.

Flight Tests with dSPACE System

We tested the observer in flight tests conducted as part of the European technology project AWIATOR (Aircraft Wing with Advanced Technology Operation) coordinated by Airbus Germany. The objective was to reconstruct the gust velocities acting on the aircraft during flight and validate them by comparing the estimated and measured structural loads. The observer was implemented on a dSPACE real-time system and installed onboard an A340-300 test aircraft. The flight data and control surface deflections are read in UDP format by a DS4502 board, which is equipped with an

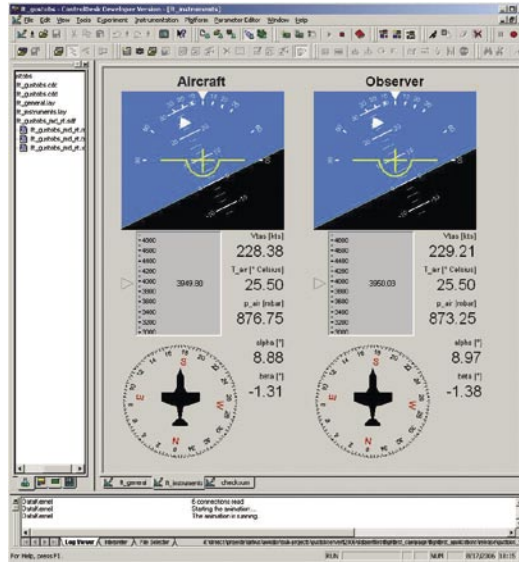

◀ ControlDesk allows comparison of measured and calculated values.

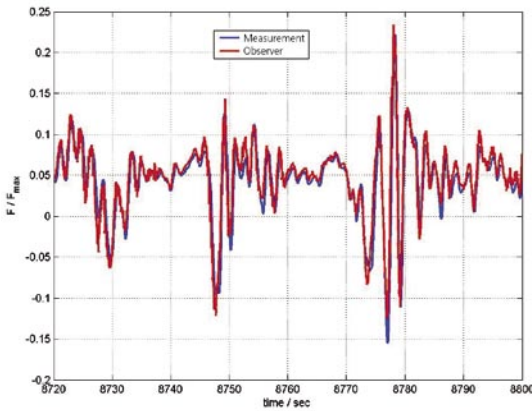

▲ There is high correspondence between the measured structural loads and the ones estimated by the observer.

Implemented within 6 Months

Using the dSPACE development environment, we implemented the observer and all the additional functions needed for the flight test within half a year. The dSPACE tools provided the necessary high computing performance and all the resources for real-time operation and for animating the results. The system worked perfectly throughout the 50 flight hours.

Lars Bensch, Michael Enzinger,
Airbus Germany
Jürgen Jusseit, DMecS –
Development of Mechatronic Systems
Germany

Ethernet communication module. Afterwards, the data are spline interpolated on the first DS1006, sampled at a common frequency of 100 Hz, and passed on to the observer hosted on the second DS1006.

The turn-around time for processing 44 measurement signals is 260 microseconds, and for the observer it is 60 microseconds. The aircraft model used in the observer includes the 6 degrees of freedom for rigid body motion and 34 modes for the flexible structure of the aircraft. The model also provides the structural loads at 20 different locations along different aircraft components.

ControlDesk and MotionDesk are used to visualize the results from the observer and for comparison with the real aircraft motion.

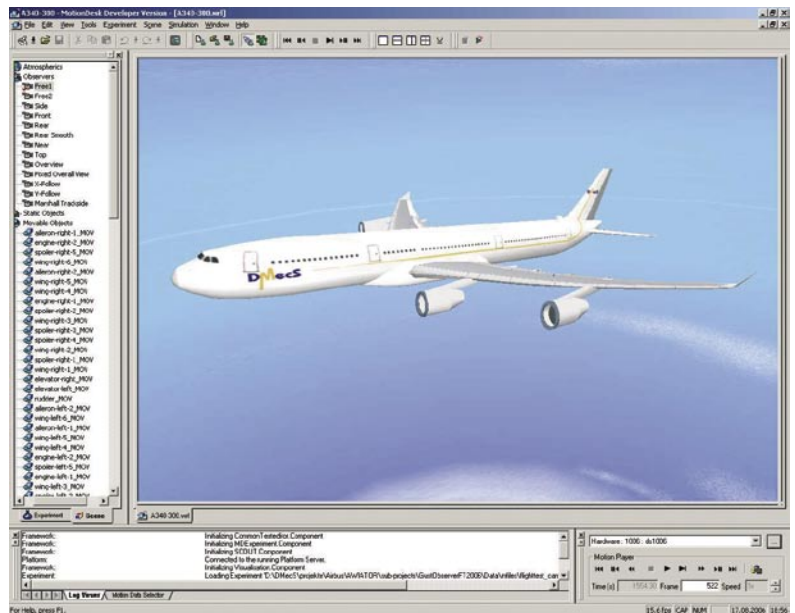

▲ MotionDesk provides 3-D animation for visualizing the results.

Optimized CVT Hybrid

Research team at Technische Universität München developing special CVT hybrid powertrain

Hybrid powertrain control based on a DS1005 PPC Board

Simulation shows great energy saving potential

A team of researchers at the Technische Universität München in Germany has developed a CVT hybrid powertrain that enables combustion engines to start up very fast. Another special feature is that it uses double-layer capacitors for energy storage. This hybrid concept is used to develop control algorithms for CVTs and for power management in hybrid vehicles. The algorithms are implemented and tested on two test benches and also in a prototype vehicle.

Working together with the companies GM Powertrain Europe, ZF Friedrichshafen AG and ZF Sachs AG, our team of researchers has developed a new kind of hybrid powertrain. The powertrain consists of a combustion engine, continuously variable transmission (CVT), electric motor and an electric energy storage module composed of double-layer capacitors (ultracapacitors). Used in hybrid vehicles, ultracapacitors are impressive in their great performance density and high efficiency due to low resistance. Moreover, they have a considerably longer lifetime than high-performance batteries.

Running the Optimized CVT Hybrid

With the CVT hybrid, vehicle start-up is performed purely electrically, meaning that the combustion engine is decoupled and the electric motor propels the vehicle via the CVT variator. The combustion engine is then coupled in according to the current and expected powertrain status. The optimized CVT hybrid provides the

ability to start the combustion engine very fast with a flywheel start. Rapid adjustment of the transmission gears brakes the electric motor. This makes the motor give off kinetic energy, which is used for starting the combustion engine very quickly and smoothly. During the flywheel start, the variable transmission can be used for the electric motor, and as the vehicle continues running, it is applied to the combustion engine by switching two toothed couplings.

Control System on the Test Bench and in the Prototype Vehicle

The overall vehicle control and the control systems for the CVT variator and power management are developed on hardware-in-the-loop (HIL) test benches and in a prototype vehicle. The development and testing processes for the algorithms and control structures are iterative. We begin by evolving new concepts and modifications in MATLAB®/Simulink® and then test them by simulation.

We have installed one dSPACE system for each of the two control systems, with identical control hardware and software. The test benches accommodate the dSPACE system with a DS1005 PPC Board, CAN and multi-I/O boards in a PX10 enclosure. In the vehicle, the boards are housed in an AutoBox. Communication with the electronic control unit (ECU) for the combustion engine runs via the CAN interface that is available as standard. We split the CAN bus between the vehicle and the combustion engine to do this. We use a second CAN controller for communication with the vehicle CAN bus, and the dSPACE system simulates the other side in each case. Following successful verification, we apply the developed software directly to the test benches and the prototype vehicle. When new modifications and improvements

The ultracapacitors for energy storage and the dSPACE system are located in the trunk of the prototype vehicle.

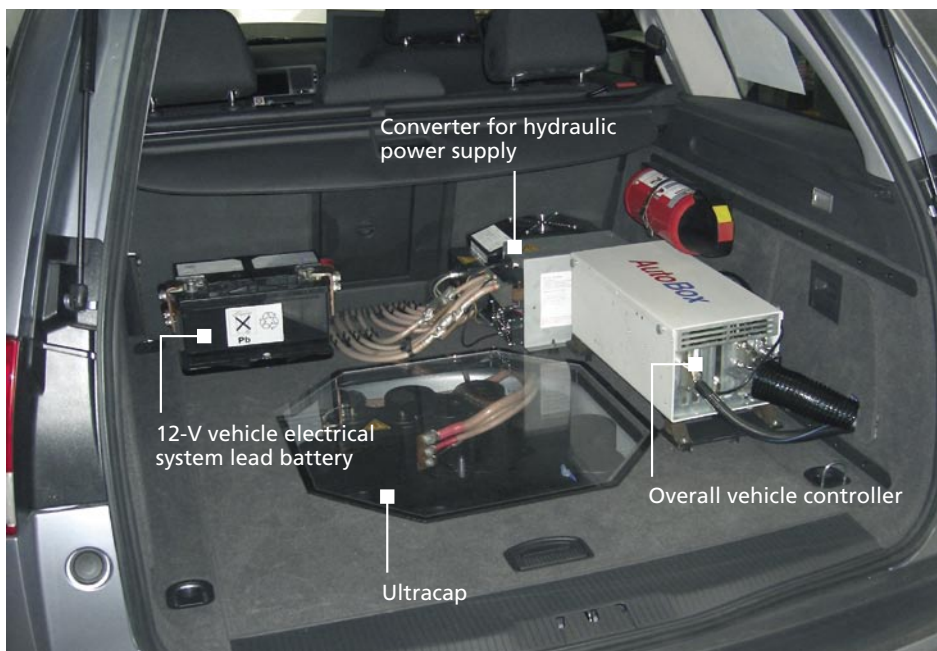

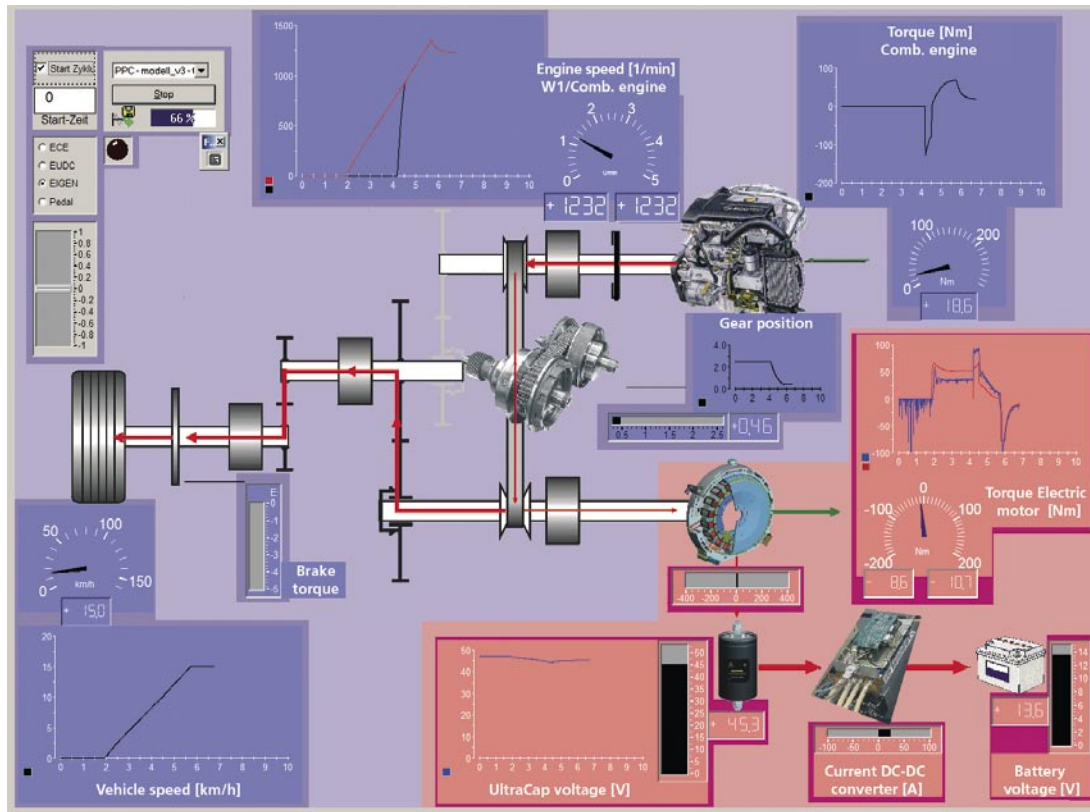

▲ During operation, the power flows are visualized in the ControlDesk experiment software according to the structure of the optimized CVT hybrid powertrain.

are made, these too are tested in the simulation. To visualize the power flow during test bench or vehicle operation, we used the powertrain structure as a basis for developing an animation in the ControlDesk experiment software, and this visualizes the power flows in the individual components.

Efficient Power Management

An important aspect of running a hybrid vehicle is to achieve optimum, consumption-reducing power management. Optimal control of the charge levels in the ultracapacitors is decisive here. The total system losses

“By using the dSPACE hardware in conjunction with MATLAB®/Simulink®, we can implement modifications to the controller structure very quickly.”

Andreas Jörg, Technische Universität München

are calculated according to the powertrain structure and also by using the characteristics and look-up tables for the individual powertrain components. To identify the driving and braking behavior and predict it as precisely as possible, we use artificial neural networks. The

additional information obtained in this way extends the procedure for loss minimization and improves power storage utilization.

We run the calculations this requires on the DS1005 PPC Board, which also executes the control algorithms for the overall vehicle control. Another challenge connected with the CVT hybrid is to coordinate the drives and couplings during the flywheel start. Test drives and measurements taken on the prototype vehicle show that combustion engine start-up occurs within a few tenths of a second and is imperceptible to the driver.

In the simulation, we already achieved a power saving potential of approx. 20% in a mixed European Drive Cycle. The aim now is to verify this by test bench trials and test drives with the prototype vehicle as the project continues.

*Andreas Jörg and Jens Schlurmann
Institute for Electrical Drive Systems
Technische Universität München
Germany*

ABS Test Bench for Teaching and Research

- **ABS test bench at Graz University of Technology**
- **Controlled by MicroAutoBox**
- **Trials on both innovative and conventional ABS and ASR algorithms**

A test bench for testing anti-lock braking (ABS) and anti-slip (ASR) algorithms was developed and set up at the Institute of Automation and Control at Graz University of Technology in Austria. A MicroAutoBox from dSPACE performs all the sequence control for the test bench, making it easy to implement both conventional and innovative ABS and ASR concepts with MATLAB®/Simulink®, Stateflow®, and TargetLink®.

Modern information technologies are opening up new ways of designing and controlling mechatronic systems. One precondition for this is a profound understanding of the underlying principles. At the Institute of Automation and Control, we developed and set up an ABS test bench for laboratory and research activities. This fulfills a main research focus in the automotive field at Graz University of Technology, and students can familiarize themselves with professional development tools at an early stage.

Design and Functional Principle

A wheel with a tire rests on a steel roller whose surface replicates the road surface and whose mass represents the inertia of the vehicle that has to be braked. First the drive unit accelerates the wheel. The

contact between the tire and the road surface rotates the roller so that its circumferential speed matches the speed of the vehicle. When this has reached the reference value, the drive unit is deactivated and the system is ready for braking. To create a realistic braking scenario, the components used have to be precisely adjusted to one another (for example, the geometry of the steel roller). In addition, we use components from production vehicles such as the brake system from a VW Golf. To measure the speed at which the wheel and steel roller rotate, inductive sensors from a production vehicle and also incremental encoders are available. The brake is activated by a foot pedal. It is currently not possible to trigger it electronically. To measure the rotational speeds and control the whole test bench, a MicroAutoBox from dSPACE is used.

▼ Schematic of the test bench with components.

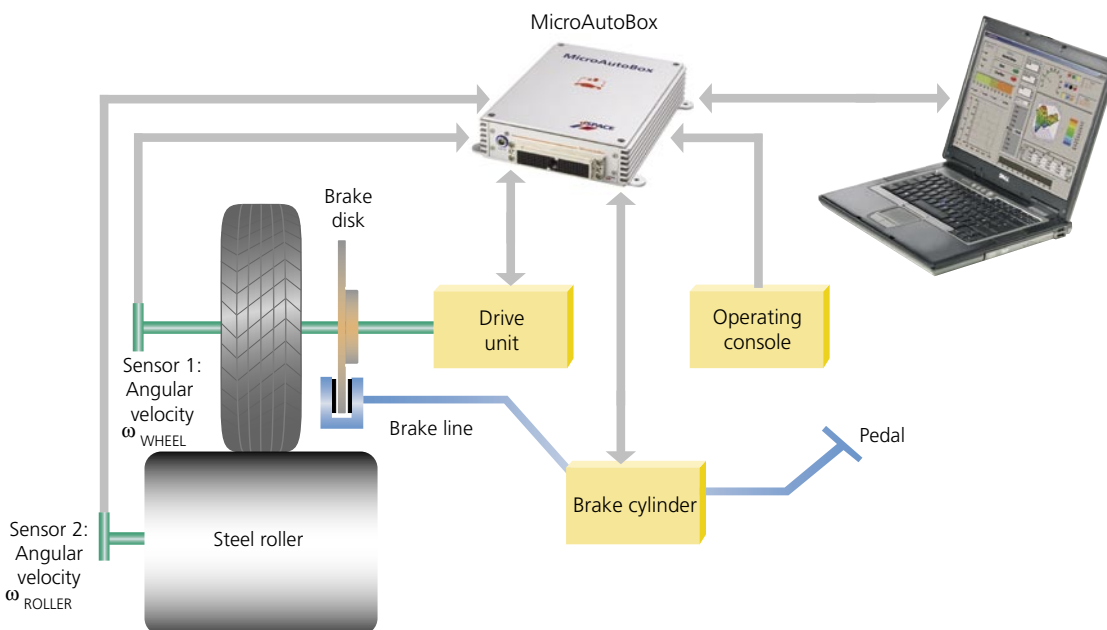

Implementing an ABS Algorithm

A typical student assignment is to design an intuitive anti-lock braking system. The system has to use MicroAutoBox to maximize the transmittable braking force between wheel and roller by setting the optimum slip. With the mechanical design of the test bench as a starting point, the students produce a mathematical model for the "wheel" and "roller" subsystems and for coupling them via the

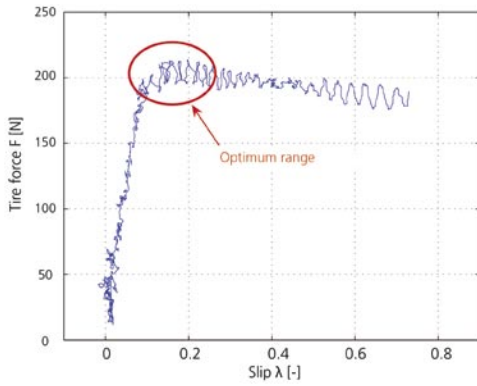

▲ Slip characteristic curve of the contact force between wheel and roller, ascertained experimentally.

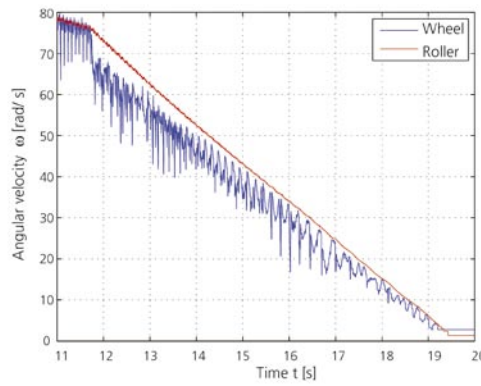

▲ Behavior of the angular velocity of wheel and roller during a controlled ABS braking procedure.

slip-dependent wheel force. The students discover that they can find the slip characteristic curve experimentally by start-up trials. The temporal derivation of the measured angular velocity that this requires

a MATLAB S-function designed for both simulation under Simulink and the real-time application on the MicroAutoBox. The optimum brake slip is the range on the slip characteristic curve that has maximum longitudinal force. Using MATLAB/Stateflow, the students then design a sequence logic that activates the appropriate valves in the brake circuit to hold the slip as close as possible to the optimum that was determined experimentally. The ABS strategy is transferred straight to the MicroAutoBox with the Stateflow Coder.

“The combination of MATLAB and dSPACE products lets us test the algorithms that were designed in teaching or research quickly and easily on the real system.”

Dr. Martin Horn,
Graz University of Technology

is performed with the Derivate Estimation Toolbox developed at the Institute. This toolbox puts the ideas of the differential algebra into practice, using

Outlook

We already ran trials on several promising approaches to ABS algorithms on the test bench described here. In particular, we developed a wheel slide protection concept for rail vehicles based on sliding mode methods. We will soon have completed the necessary conversion of the test bench to represent the wheel/rail contact.

*Dipl.-Ing. Josef Zehetner
Ao. Univ. Prof. Dr. Martin Horn
Institute of Automation and Control
Graz University of Technology, Austria*



▲ Design of the test bench with MicroAutoBox and operating console.

Glossary

Incremental encoder –
Sensor for capturing changes in position (linear or rotating).

Sliding mode –
Robust control method for nonlinear systems with restricted parameter variations and/or model uncertainties.

HIL for a Three-Wheeler Scooter

➤ Piaggio MP3 scooter with two front wheels

➤ HIL simulation at ELASIS

➤ Test automation with AutomationDesk

Piaggio developed the three-wheeler scooter MP3 with two front wheels. The two independent and balancing wheels on the front suspension assembly frame provide greater dynamic stability performance than a standard scooter. The innovative, electronically controlled locking system keeps the vehicle upright without using the usual central stand. The complete system of networked electronic control units (ECU) was tested by ELASIS using a dSPACE hardware-in-the-loop (HIL) simulator.

Three-Wheeler Scooter

Ordinary scooters with two wheels are a little bit instable, and you have to be very careful while driving on slippery road surfaces. Our new three-wheeler scooter MP3 with two front wheels has great advantages in terms of maneuverability and safety, due to better road holding in whatever grip conditions and on bad surface roads. It has a parallelogram suspension anchored to the frame that allows a tilt angle of up to 40°. The locking mechanism for the front suspension mainly consists of the NST (Nodo Stazionamento, Locking Mechanism Control Unit) and the engine control unit NCM (Nodo Controllo Motore). The implementation of the NST is feasible only if the electronic control unit (ECU) which controls it is connected to the NCM via a CAN network

▼ The parallelogram suspension holds the two front wheels.

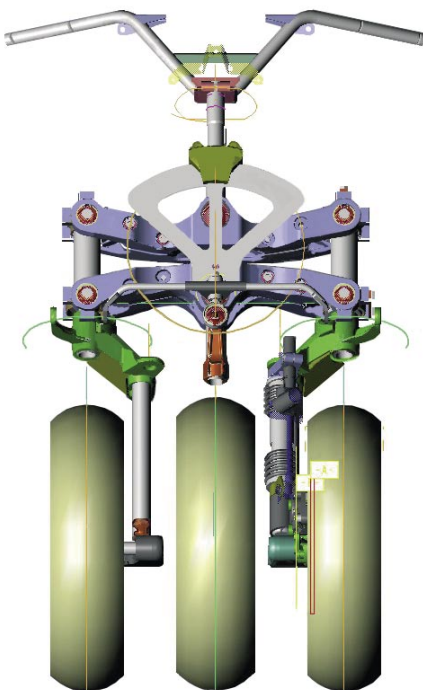

Upright Without Kickstand

Our new locking system NST allows “easy parking” without the kickstand, even on an inclination or with a difference in height of up to 20 cm between the two front wheels. When the pilot pushes the lock request lever, the lock conditions have to be simultaneously verified:

- Vehicle speed below a threshold which is a function of vehicle deceleration
- Throttle closed and engine speed under a threshold

If these conditions are not reached after a certain time span, the lock request is



▲ The three-wheeler MP3 scooter from Piaggio.

rejected. If the locking conditions are true, a lamp on the dashboard starts flashing and is lit permanently when the suspension is locked.

When the driver is on the scooter, the suspension is unlocked on the driver's request and, for safety reasons, if one of the following conditions is verified:

- Engine speed above a threshold which assures that the clutch is closed
- Vehicle speed above a threshold

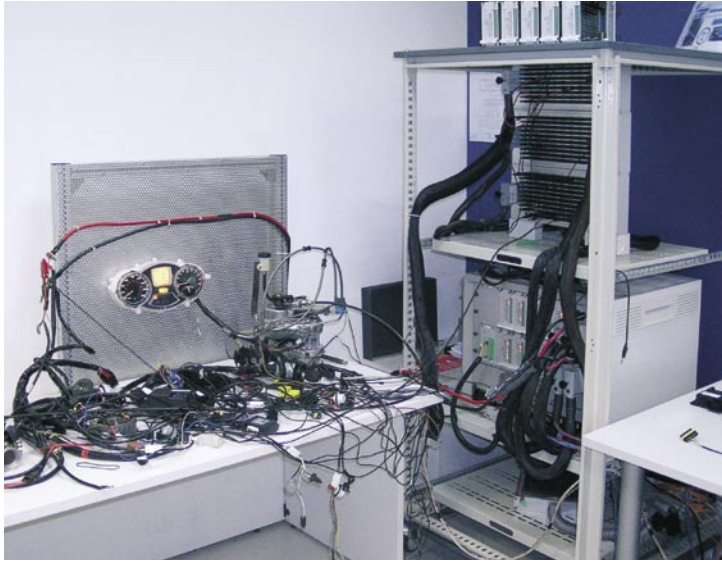

▲ The hardware-in-the-loop setup with a dSPACE Simulator Mid-Size.

Simulation with dSPACE Simulator

To test the NST thoroughly, we needed a lot of severe testing conditions that are difficult or even dangerous to reach, like cornering sharply or braking at top speed on rain-soaked surfaces. Moreover, it is almost impossible to generate exactly the same testing condition twice. We tested the NST and the NCM simultaneously on the CAN network. The model of the engine runs in real time to verify correct control system integration on the CAN network. The simulation therefore had to provide a short turn-around time. We also needed a test platform with closed-loop simulation, the facility for test automation, and fault insertion (FIU) capabilities. To make sure the locking mechanism will be reliable even if other components fail, FIU is very important. Having this in mind

“Testing on an HIL platform accelerated our verification and validation process significantly.”

Ferdinando Ferrara, ELASIS

and working towards extending the same development platform for different ECUs, we at ELASIS selected a dSPACE Simulator Mid-Size as real-time hardware. We built the model for the scooter behavior in MATLAB®/ Simulink® and computed it with a DS1005 PPC Board. The I/O signals were generated and measured by the DS2210 HIL I/O Board, which also performed the signal conditioning. This board contains special functions for generating and reading ECU crank-angle-based signals with high accuracy and convenience.

Test Automation

After the HIL platform was completely functional, test automation played a crucial role by allowing us to do lights-out testing on the ECU. For defining these test patterns and organizing the results, we used AutomationDesk from dSPACE.

In later stages of development, we used the HIL simulator as a validation tool to evaluate any change to the already developed software. In the final part of development dSPACE Simulator’s test automation ability was very important, because this allowed repeatable execution of test sequences to

ensure that changes in one area do not affect functions elsewhere.

Ferdinando Ferrara, Massimiliano de Manes, ELASIS Pontedera, Italy

Edoardo Ruggiero, Piaggio Pomigliano d’Arco, Italy



▲ The MP3 provides a tilt angle of up to 40°.

Control of a Power-Split Hybrid-Electric SUV



- Hybrid electric SUV developed at Ohio State University
- Government, industry, and university partnership
- Supervisory control implemented on MicroAutoBox

Ohio State University students designed and built a power-split hybrid-electric vehicle (HEV) for the Challenge-X vehicle development competition. They re-engineered a mid-sized sport utility vehicle (SUV), provided by General Motors Corporation®. The Ohio State team used dSPACE's MicroAutoBox as the primary vehicle control unit to perform fundamental hybrid powertrain operations. dSPACE Inc. also is one of the Silver Sponsors for this event.

Hybrid electric vehicles (HEVs) reduce dependency on nonrenewable fuels and significantly eliminate pollutant emissions, while maintaining similar consumer acceptability, safety and utility features as their non-hybrid counterparts. No wonder they are growing in popularity. The Challenge-X competition is a government- and industry-sponsored event that motivates engineering students to find innovative solutions to improve fuel economy and reduce emissions for mid-sized SUVs, which are popular in the North American market.

The Ohio State Hybrid-Electric SUV

As part of this competition, Ohio State University (OSU) engineering students developed an HEV that is powered

by a combination of a turbocharged diesel engine, a high-voltage, belted starter-alternator (BSA) and an AC induction type traction electric machine. In this configuration, the rear and front drive systems are coupled through-the-road.

The selected vehicle architecture and control strategy enabled the use of the following features:

- **Energy optimization via adaptive control:** The control strategy utilizes a weighted combination of actuator torques to fulfill the driver's power request under normal driving conditions. This power split is based on the estimated efficiencies of all hybrid drivetrain components. Using statistical techniques, the control strategy also adapts itself to driving conditions to achieve further improvements in fuel savings.
- **Electric launch:** Due to the high torque capacity of electric machines at low speeds, our control strategy launches the vehicle using the rear electric drive. This provides a smooth and quiet vehicle launch, since the engine is off during this period. The electric-only operation also helps to achieve additional fuel savings by eliminating engine idling while also operating the vehicle in zero-emissions mode.
- **Start-stop:** We have the ability to start and stop the engine within less than 0.3 seconds using the BSA system. This feature enhances consumer acceptability of our vehicle and helps us to utilize the electric-only operation in a variety of driving conditions.



▲ Ohio State Challenge-X hybrid-electric vehicle competing in a dynamic handling event.

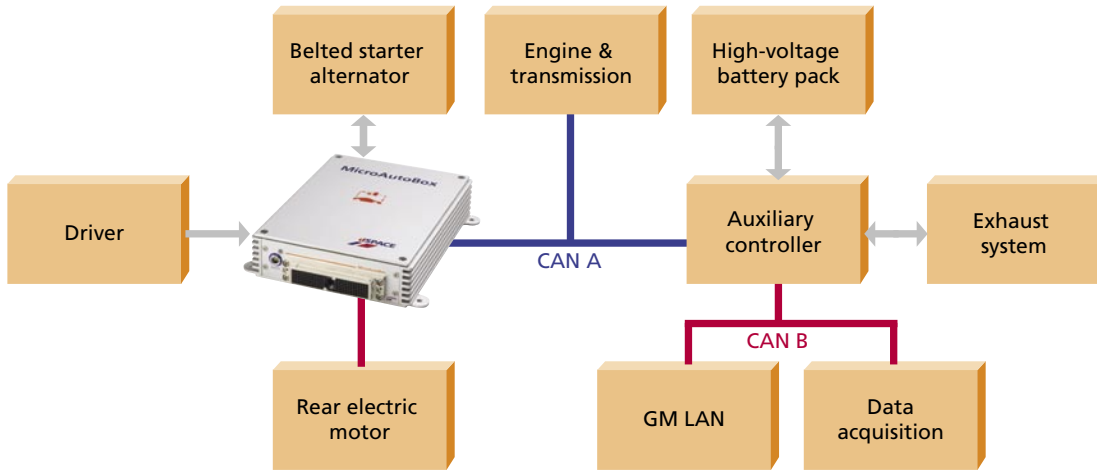

▲ The MicroAutoBox interfaces with the powertrain control modules via dual CAN buses and several I/Os.

- **Regenerative braking:** During deceleration, part of the vehicle's lost kinetic energy is recuperated by utilizing electrical braking via the rear electric machine. The braking power generates electrical current which is stored in the high-voltage battery pack.
- **Electric traction control:** Our vehicle has the ability to drive rear and front axles individually, which enables us to do electric traction control. The traction control system appropriately changes the power split between the front and rear axles when an adverse driving or weather condition is detected.
- **Driveline torque smoothing:** The presence of various hybrid operating modes requires a careful blending between the modes during transients. This prevents the high-frequency dynamics from being excited and helps to maintain a high level of driving comfort. We designed a hybrid transition controller for the vehicle to avoid such issues.

Control Implementation Using the MicroAutoBox

Prior to the actual implementation, we tested the performance of its control strategy using custom-designed vehicle simulation tools developed in the MATLAB®/ Simulink® environment. After initial testing, the control strategy was implemented on the MicroAutoBox system via dSPACE's Real-Time Interface and the RTI CAN Blockset. MicroAutoBox is the primary vehicle control unit to perform fundamental hybrid powertrain

operations such as energy optimization, battery charge control, engine start-stop, drivability control, electric traction control, and regenerative braking. In the student-designed vehicle, the MicroAutoBox communicates with several control modules through dual CAN buses. The versatile I/O interface simplified the integration of several analog and digital I/Os into the controller for

"ControlDesk greatly reduced our controller development time."

Kerem Koprubasi, Ohio State University

the added hybrid components. The fast numerical processor featured by the MicroAutoBox made it possible to implement computationally burdensome algorithms onboard the vehicle.

The OSU engineering team greatly benefited from the real-time calibration capability of the MicroAutoBox system. A supervisory control algorithm contains numerous parameters that need to be tuned to achieve high performance. dSPACE's ControlDesk software allowed us to modify these parameters and monitor I/O signals in real time. This feature greatly reduced our controller development time.

*Kerem Koprubasi
Ohio State University
Columbus, Ohio, USA*

dSPACE Inc. congratulates the Ohio State University team on its fine results during the Challenge X event.

For the individual scores in the different categories, please see www.challengex.org/competition/2006_competition_results.html

Efficient Test Processes

- **Mechatronic simulator for ECU tests on steering systems**
- **Process optimized by coupling AutomationDesk and DOORS**
- **Greater transparency and efficiency for everyone involved**

ZF Lenksysteme GmbH develops and produces steering systems for passenger and commercial vehicles. The company uses the requirement management tool DOORS® for drawing up software requirements and specifying ECU tests, and the test automation software AutomationDesk from dSPACE for implementing, executing, and documenting the tests. AutomationDesk and DOORS® are coupled via the dSPACE Connect&Sync Module, giving ZF Lenksysteme a very clear and simple environment for designing ECU tests.

Optimized Test Processes

Our objective was to optimize our test processes and design them so developers who are new to the team can easily get started in ongoing projects. We chose DOORS, the requirement management tool from Telelogic, for defining software requirements and associated test specifications. Then to make the next steps in the process (test implementation/test execution) easy to track, we opted for dSPACE's AutomationDesk, the graphical test automation software. Our experience with both tools was positive, so the next logical step was to couple DOORS and AutomationDesk via the dSPACE Connect&Sync Module to increase the transparency of our workflows.

Hardware Landscape with HIL Simulator

Our hardware landscape for testing power steering systems consists of a terminal PC with DOORS and AutomationDesk for accessing the HIL simulator. The HIL simulator provides the simulation data for the power steering system under test. This consists of an ECU, a motor (the actuator that generates the

steering forces) and a system of counteracting forces for introducing variables such as torques and engine speed, which in a real vehicle would affect the steering via the chassis. The power steering returns various measurement values (steering torque/angle etc.) to the HIL simulator as the result.

Workflow with DOORS, AutomationDesk and Connect&Sync Module

The first step is to create the software requirements as well as the test specifications in DOORS. Because we do this entirely in DOORS, we can simply link each software requirement with its associated test specification to ensure that there is no ECU requirement without its own test specification.

The second step is to transfer the test specification to AutomationDesk. The Connect&Sync Module provides a set of rules for this transfer process, defining how structures and data from DOORS are mapped in AutomationDesk. The structures and data that were designed in DOORS then also appear in AutomationDesk.

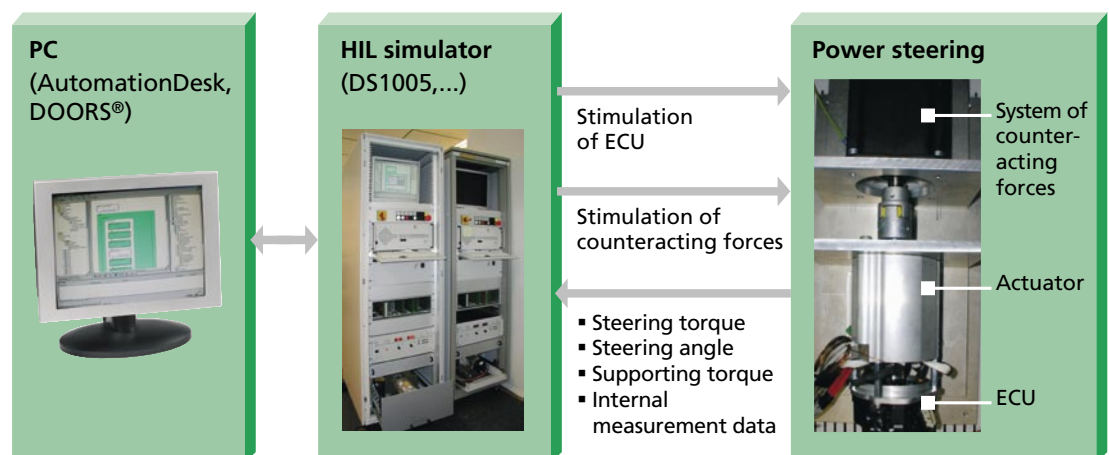

▲ The hardware landscape for testing power steering systems.

DOORS

Step 1: Creation of software requirements and test specification

ID	Status	Object Heading and Object Test	Uebungung
TS-104	in Bearbeitung	105 Vorlage	
TS-106	beendet	105.1 TS-1026: Auftreten der Motorphase U im Drive	Leboreato
TS-107	beendet	105.1.1 Beschreibung	Leboreato
TS-108	beendet	Abstrakt: Motorphase U wird im DRIVE-Mode aufgetrennt.	Leboreato
TS-109	beendet	Vorbereitung: SO aus PDP aus	Leboreato
TS-100	beendet	Teststrategie: (A) System aufsetzen in den Drive-Modus (A) Motorphase U über Relaisbox aufsetzen (A) Vorgabe Lastübergang (Leistungsweg): Dauer, 20%, 0.5Hz, Dauer 2s (A) SO2 Lastzustand und Status HBC während Lastübergang aufzeichnen (A) Status HBC aufzeichnen (A) Fehlerregister auslesen	Leboreato
TS-101	beendet	Sollzustand: Solange keine Lastübergänge stattfinden befindet sich das SO in der Stillstehende-Abschaltung. Der Phasenstoß kann hier nicht erkannt werden. Erst wenn eine Motorübergang angefordert wird und die Phase freigegeben werden, soll der Phasenstoß erkannt werden. KPC_SMCURR / KFA_MCURR SO 2s nach dem ersten Lastübergang im Mode ERROR	Leboreato
TS-102	beendet	Nachbereitung: Motorphase U wieder verbinden; Fehlerregister löschen	Leboreato
TS-103	beendet	105.1.2 Parameter	Leboreato
TS-104	beendet	EXP_STATE_1 = HBC_ERROR	Leboreato
TS-105	beendet	EXP_KPC_1 = KPC_SMCURR	Leboreato
TS-106	beendet	EXP_KFA_1 = KFA_OC	Leboreato

AutomationDesk

Step 2: Transfer of the test specification and parameters

Step 3: Test implementation

Step 4: Test run

Step 5: Transfer of the test results (passed, failed or undefined)

DOORS **Test results**

ID	Status	Object Heading and Object Test	Uebungung	dSPACE AUD.
TS-104	in Bearbeitung	105 Vorlage		
TS-106	beendet	105.1 TS-1026: Auftreten der Motorphase U im Drive	Leboreato	Passed
TS-107	beendet	105.1.1 Beschreibung	Leboreato	
TS-108	beendet	Abstrakt: Motorphase U wird im DRIVE-Mode aufgetrennt.	Leboreato	
TS-109	beendet	Vorbereitung: SO aus PDP aus	Leboreato	
TS-100	beendet	Teststrategie: (A) System aufsetzen in den Drive-Modus (A) Motorphase U über Relaisbox aufsetzen (A) Vorgabe Lastübergang (Leistungsweg): Dauer, 20%, 0.5Hz, Dauer 2s (A) SO2 Lastzustand und Status HBC während Lastübergang aufzeichnen (A) Status HBC aufzeichnen (A) Fehlerregister auslesen	Leboreato	
TS-101	beendet	Sollzustand: Solange keine Lastübergänge stattfinden befindet sich das SO in der Stillstehende-Abschaltung. Der Phasenstoß kann hier nicht erkannt werden. Erst wenn eine Motorübergang angefordert wird und die Phase freigegeben werden, soll der Phasenstoß erkannt werden. KPC_SMCURR / KFA_MCURR SO 2s nach dem ersten Lastübergang im Mode ERROR	Leboreato	
TS-102	beendet	Nachbereitung: Motorphase U wieder verbinden; Fehlerregister löschen	Leboreato	
TS-103	beendet	105.1.2 Parameter	Leboreato	
TS-104	beendet	EXP_STATE_1 = HBC_ERROR	Leboreato	
TS-105	beendet	EXP_KPC_1 = KPC_SMCURR	Leboreato	
TS-106	beendet	EXP_KFA_1 = KFA_OC	Leboreato	

▲ Typical workflow in the tool landscape consisting of DOORS, AutomationDesk and the Connect&Sync Module. Because the two tool worlds are linked, test results can be tracked from one to the other.

The third step is test implementation in AutomationDesk. This is based on the structures and data that were generated, which greatly facilitates our work. The

“Coupling AutomationDesk and DOORS via dSPACE’s Connect&Sync Module has greatly simplified ECU testing at ZF Lenksysteme.”
Heiko Hägele, ZF Lenksysteme GmbH

fourth step is the test run, while in the fifth step the test results (passed, failed, or undefined) are transferred back to DOORS via the Connect&Sync Module.

Advantages of Coupling DOORS and AutomationDesk

➤ **Clearly organized working environment**

The Connect&Sync Module keeps the data and structures synchronous in DOORS and AutomationDesk, resulting in high consistency throughout the process.

- **No need for additional management files**
 We no longer have to keep work-intensive and error-prone lists to synchronize test specification and implementation. Lists are also not needed for statistical evaluations, as that can all be done in DOORS.
- **Better quality assurance**
 DOORS contains the current test results as well as the requirements, so tests are more transparent for the management level, which greatly facilitates quality assurance.

Heiko Hägele
 ZF Lenksysteme GmbH
 Schwäbisch Gmünd
 Germany

Comfort Mode for Helicopters

- Reducing noise and vibrations in helicopters
- Additional, piezoelectrically controlled flaps in the rotor blades
- dSPACE prototyping system for real-time control of the additional flaps

To reduce helicopter noise and vibrations, Eurocopter Germany has developed piezoelectrically controllable flaps for the rotor blades. The deflections of the flaps are controlled by dSPACE equipment, and reduce noise by almost 50% and vibrations by virtually 90%. Dieter Roth, in charge of testing at Eurocopter, spoke to dSPACE NEWS about his experience with dSPACE tools in developing this technology.

Could you briefly explain what the piezoflap rotor is all about?

Helicopters often develop a kind of chugging noise, which is caused by one rotor blade colliding with the trailing vortex of the rotor blade in front. This is particularly loud during landing, because in this situation each rotor blade can be completely immersed in the trailing vortex. Vibrations are another problem and occur during travel flight. They are caused by the forward-moving rotor blade cutting through the air faster than the backward-moving blade because the flight speed of the helicopter is added to its rotational speed, giving it greater lift. As a consequence, the rotor blades beat up and down as they rotate, and this is transmitted to the cockpit as vibrations. We use the piezoelectrical flaps in the rotor blades to minimize the

noise and vibrations. During the landing approach, the flaps deflect the air vortex away from the following rotor blade, and during travel flight their deflections generate additional forces that help to counteract

"If I had to give school grades, I would say the dSPACE development environment is the top of the class."

Dieter Roth, Eurocopter Germany

the vibrations. There are approximately 35 flap deflections per second, which we control with a dSPACE prototyping system.

In the race to develop adaptive rotor systems, you have left strong competitors from the USA and Japan far behind. What part do the dSPACE tools play in this?

A decisive part. Because we need to perform very many different control tasks with our test helicopter, we must be flexible in programming. This is where the dSPACE tools can really show their true strengths. Controller designs under MATLAB®/Simulink® are easy to implement and then very easy to handle via ControlDesk. All the declared variables are available and above all changeable online. Access to the hardware is very simple, and the solution for monitoring individual tasks – we often have three tasks with different sampling rates – is excellent.

Do the dSPACE tools interact smoothly with your other tools?

We try to use as many dSPACE components as possible, but we do have some other hardware components which we cannot "marry" directly to our



▶ Dieter Roth, in charge of testing at Eurocopter Germany: "The dSPACE tools play a decisive part in our control tasks."

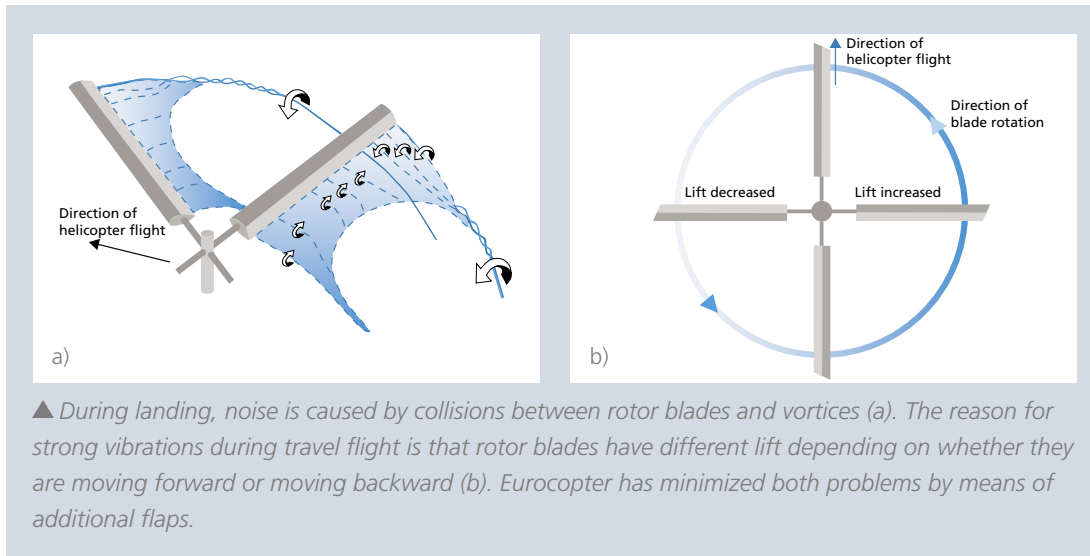

dSPACE tools. However, the solutions provided by dSPACE Support for such problems have all been excellent.

What is your overall impression of the development environment with dSPACE tools?

If I had to give school grades, I would definitely say they were the top of the class. We often had problems with other hardware, but none so far with dSPACE tools.

Are there any plans to use the piezoflaps for the primary control of helicopters?

This is the object of the INROS project (innovative rotor control) currently being funded by the German Federal Ministry of Research. The plan of action is two-fold: We aim to replace parts of the primary control – control rods and swash plate – with a combination of actuators, and also use the piezoflaps in a supporting role. A prototype for the rotor test bench will be ready by the end of 2009.

Will the level of electronics in helicopters continue to grow in the future?

Oh, yes. At the moment, for example, we have built a “special helicopter” for the German Aerospace Center (DLR). This helicopter has a new kind of “fly-by-light” control and is monitored by computers. The issue of flight control will also increasingly come to the fore, though that has safety-critical aspects that also have to be considered, of course.

Does Eurocopter use dSPACE tools in any other projects?

Yes, there are currently two other projects: A new modern flight control (AFCS) for the military transportation helicopter CH53 and the use of active force generators in place of passive mass dampers in the helicopter cell to minimize vibrations, called Active Control of Structural Response (ACSR).



What about the future, are you planning any other projects?

We are currently designing control algorithms to implement rotor stabilization for damping enhancement. This could mean that we could do without passive damping mechanisms in the future, which would in turn reduce costs and maintenance. In addition, we are looking into a performance booster for fast forward flight and turning with high load multiples. This uses a control to reduce the load on the rotor, which is under extreme stress in these flight states, achieving not only less vibration but also a lower power requirement.

▲ The rotor blade tip with the additional flaps. There are approx. 35 flap deflections per second, which Eurocopter controls with a dSPACE prototyping system.

Mr. Roth, thank you for talking to us.

Snow Cat on a Hook

- **PistenBully 600 W from Kässbohrer**
- **Ski run preparation vehicle for steep slopes**
- **Traction control developed with MicroAutoBox**

Kässbohrer Geländefahrzeug AG has developed new winch electronics for its PistenBully 600 W. The winch enables the vehicle to rope itself down steep slopes and climb back up again. The existing electronics were mapped to a dSPACE system, where their functions were extended and improved. Traction control functions were developed very efficiently and quickly with MicroAutoBox from dSPACE. The MicroAutoBox was also used to verify the production electronic control unit (ECU).

New Winch Electronics

Kässbohrer's snow slope preparation vehicle, the PistenBully 600 W, is used to maintain and smooth ski runs. The vehicle is about 10 meters long, with a plow blade in front to push the snow aside and a tiller at the rear to break up clumps of ice and snow. The 1.50 meter long tracks distribute the vehicle's weight of 9 tonnes so widely that the vehicle exerts less pres-

sure on the ground than a person walking. To work on steep mountain slopes, the vehicle is equipped with a cable winch, using a 1000-meter-long and 11-millimeter-thin steel cable to slide down slopes of up to 45° and pull itself back up again.

modern vehicle networking, various function nodes are connected via a CAN bus, so we had to replace the existing winch electronics. Since the functions of the replacement electronics also needed improving and extending, we decided to replicate them in-house. This meant we could respond to customers' wishes better and at the same time develop replacement electronics that were 1:1 compatible with the winch electronics in older vehicles.



▲ The 11-millimeter-thin steel cable allows work on slopes of 45°.

sure on the ground than a person walking. To work on steep mountain slopes, the vehicle is equipped with a cable winch, using a 1000-meter-long and 11-millimeter-thin steel cable to slide down slopes of up to 45° and pull itself back up again. Up to now, we always used third-party control electronics for the traction control. However, with

Traction Control with MicroAutoBox

We studied the existing winch electronics, taking measurements to identify their basic functions and then replicate and modify them. The first step was to model and validate the electronics as a function map in MATLAB®/Simulink®. The model was then implemented on the MicroAutoBox by means of the Real-Time Interface, both from dSPACE. The MicroAutoBox acted as a bypass system, replacing the functions that needed modifying with the new ones so we could test them on the actual cable winch. Thus at a very early stage, were able to test whether new functions worked correctly in the envisaged

constellation. The original ECU reads all the sensors and signals and controls the winch's actuators and sensors as before. It sends the signals that it reads to the MicroAutoBox via CAN.

The MicroAutoBox is the control unit that calculates the required traction along with other control variables and returns the results to the ECU via CAN. We pro-

grammed the CAN connection of the ECU graphically using the CAN MultiMessage Blockset from dSPACE. This gave us complete access to variables such as actual and desired cable traction and the function states of the winch and vehicle.

Access via ControlDesk

We access the controller's internal variables with the ControlDesk experiment software from dSPACE. The variables include various dynamic components in the controller such as integrative parts, limiting actuators and controller output.

We can therefore analyze the functions quickly and adapt them online. To ensure that the controller algorithms always have current values, it was important

“Using dSPACE tools, development was 50% faster than with conventional methods.”

Dr. Alexander Bulach, Kässbohrer Geländefahrzeug AG

to synchronize the data exchange between the ECU and the MicroAutoBox, which was no problem at all. At the same time, we used bypassing to verify the production ECU used in older versions of the winch electronics. We performed the necessary optimizations of control functions on the vehicle itself. These modifications were then fed back into the model to improve it.

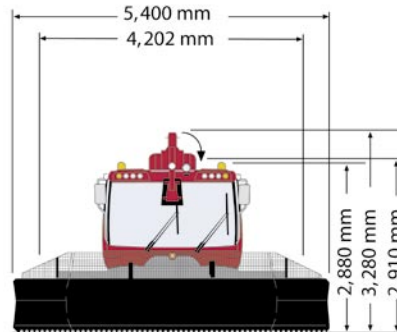
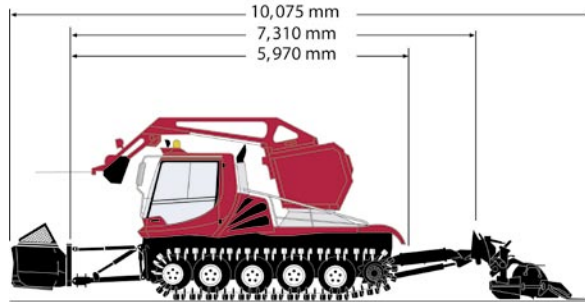

▲ The side and front dimensions of the PistenBully 600 W.

With the tool chain it took only a short time to model the functionality of the winch electronics. Compared with conventional programming, using dSPACE tools for function development gave us a time-saving potential of approx. 50%.

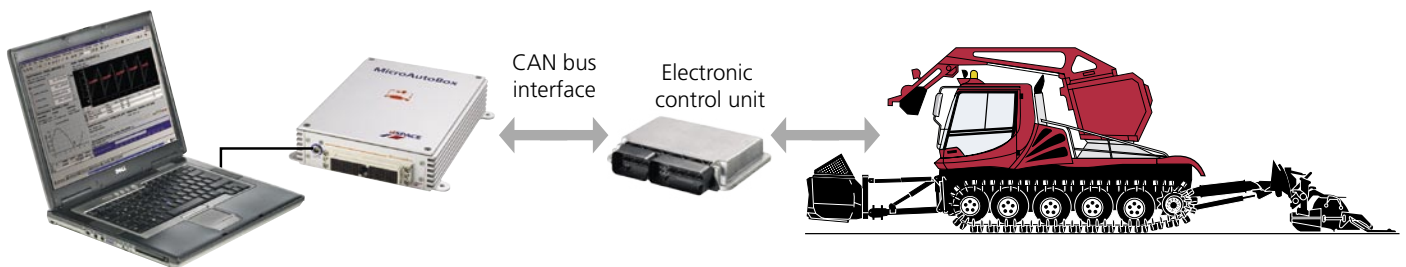

▲ Function modifications are transferred to the ECU via the MicroAutoBox.

Field Trials

We coded the modified traction control functions, tested them thoroughly in the field, and optimized them within the overall system. The dynamic cable traction behavior had to be tested for this, as there are two overlapping control loops. So far, we have implemented and tested the basic functions. New functions have been partially tested and are still in the prototype stage. It took approximately one week to test basic functionality on the vehicle.

*Dr. Alexander Bulach
Kässbohrer Geländefahrzeug AG
Laupheim
Germany*

Virtual Outlander

- **Mitsubishi using a virtual vehicle to develop a new Outlander**
- **Real-time execution of Automotive Simulation Models (ASM) with a network simulator**
- **Monkey tests integrated into test automation**

To develop the new Mitsubishi Outlander, a test system was required for the over 20 networked electronic control units (ECUs) and various electric drives. Mitsubishi aimed to meet the defined market launch deadlines and also fulfill quality requirements by running early integration tests on the networked functions. The test system was designed as a virtual vehicle consisting of a network simulator and the Automotive Simulation Models (ASM) from dSPACE.

Selecting a Test System for Integration Tests

The existing solutions for monitoring CAN traffic when failures are inserted in the system via switch box were no longer sufficient for the complexity of Mitsubishi Outlander's control systems. In particular, it was not possible to implement systematic, reproducible tests based on these tools with reasonable effort.

- Simulation of lock logics for electric doors and electric glass roof
- Different country variants: Japan, USA, Europe
- Installation of real parts such as power windows and power hatch in the HIL environment

"Virtual vehicle tests in real time are indispensable to assuring the quality of complex ECU systems."

Kunihiro Sakai, Mitsubishi Motors



▲ *The new Mitsubishi Outlander is equipped with numerous networked ECUs and various electric drives for comfort functions.*

We therefore began by evaluating test systems from several providers. The hardware-in-the-loop (HIL) solutions from dSPACE came out on top. Good, intensive cooperation with dSPACE also convinced us. Even during the evaluation, we managed to locate a field fault using the dSPACE Simulator Mid-Size, which greatly boosted acceptance.

The Outlander Project's Special Requirements

The variant diversity and various internal requirements resulted in the following requirement profile for the test system:

- Simulation of three different engines: 4- and 6-cylinder gasoline and 4-cylinder diesel
- Simulation of continuously variable transmission (CVT) and automatic transmission
- Integration and simulation of supplier models (transmissions, electric drives)

Different hardware versions of some ECUs had to be included. This required simple version detection on the part of the test system so that the correct test models are automatically activated when the ECU changes.

Another requirement was to perform automated monkey tests for all the vehicle's driver functions that can be activated by switch or button.

Configurable Virtual Vehicle

With this requirement profile as the basis, we worked with dSPACE on a specification for an extensive test system. The data and facts for the ECUs were included in the form of data sheets and ECU description files.



▲ *The virtual vehicle testing system as it is installed in the laboratory.*

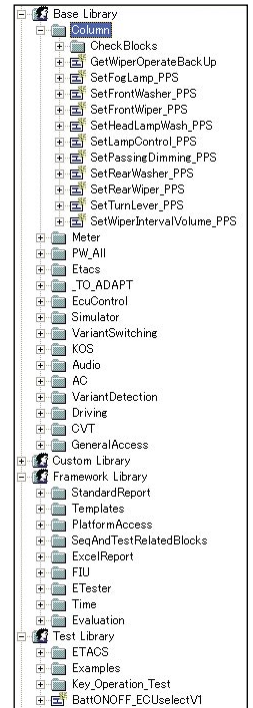
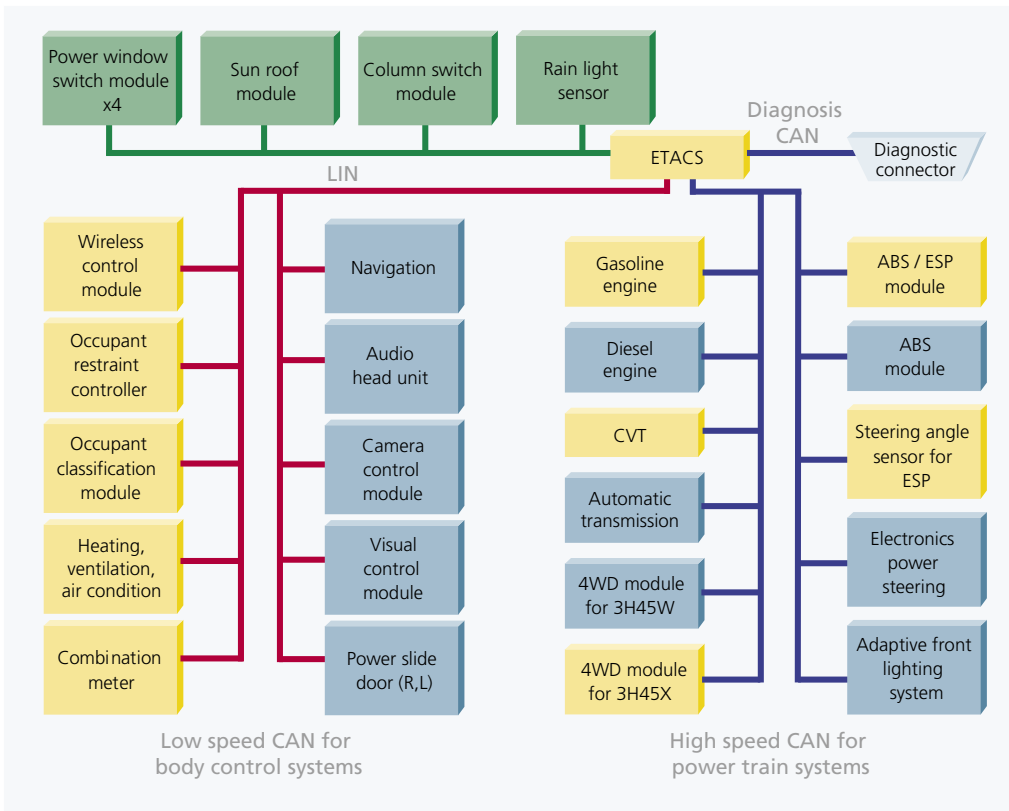

▲ The diverse ECUs and bus systems are connected by a central ECU, the Enhanced Total Access Communication System (ETACS).

▲ AutomationDesk libraries are the basis for fast, efficient test execution.

The specified system is called a virtual vehicle, and it is equipped with push-button configuration for different variants. It consists of five networked HIL simulators, to which all the ECUs and real parts have to be connected. The models of the components to be simulated are installed on the simulators. For the engines and vehicle dynamics, these are the ASM models from dSPACE. The models of various electric drives and the CVT were provided by the suppliers and integrated into the dSPACE models. Thanks to the expertise of dSPACE, the specification was quickly completed.

Installation in Two Phases

To put the system into operation, we decided to perform two-phase installation: First the simulators for testing the body system were delivered and commissioned, then the test solutions for the powertrain were added. This procedure was successful. Splitting in two steps ensured that we could begin the complex integration tests on the new electric components at a very early stage.

Variant-Based Integration Tests

The installed test system is able to simulate all the variants of the Mitsubishi Outlander in real time. Variant handling is carried out in a user interface created

“With the Automotive Simulation Models (ASM), we can virtualize the chassis and powertrain of the Mitsubishi Outlander realistically.”
Masahiro Kaneda, Mitsubishi Motors

with ControlDesk and takes only minutes. All the models are then correctly configured, the required parameter sets are loaded, and where necessary relays are switched to address the real installed components – all automatically. Hardware version detection for the ECUs was implemented as intelligent evaluation of connector coding. This automatically selects the correct variants for different ECU versions. It makes it particularly easy to replace ECUs quickly and then test them immediately. We run all tests with AutomationDesk. dSPACE set up a test frame in which our test engineers integrated all the test cases.

Virtual Vehicle in Action

The new virtual vehicle based on dSPACE network simulators enables us to test all the ECU functions in the Mitsubishi Outlander, including diagnostic functions, reliably and systematically with a single test system. In addition to the systematic tests, we successfully perform monkey tests to validate the controls of the new electric body systems. dSPACE developed a special function for this, which works like a random generator and can be connected with all the relevant function inputs. With the new dSPACE system we can perform functional test as well as study the behavior of all ECUs and network communication during any maneuver. During all tests, the HIL also lets us monitor the power consumption of each ECU, which becomes especially important when the ECU network enters sleep mode.

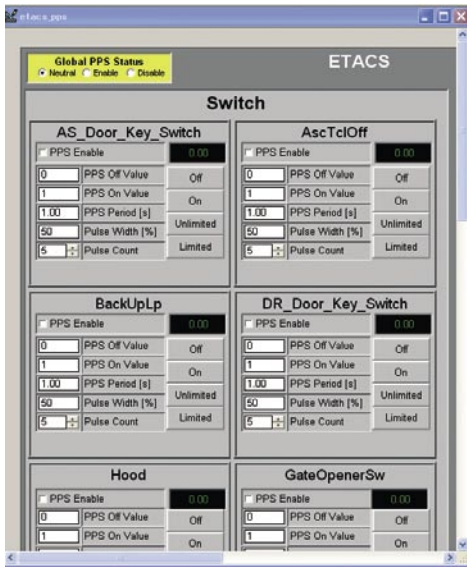

▲ ControlDesk layout for controlling and evaluating a lock logic featuring a Programmable Pulse Stimulus (PPS) for monkey tests.

Automated Tests Achieve Objectives Faster

The greatest advantage of an HIL system is test automation. In place of manual procedures, complex test sequences can be defined, executed, and reproduced as often as desired. Thus, it is easy to validate new versions of the ECU software for errors that were remedied. Simple test routines can be created, combined, and integrated in sequences for the numerous combinations of inputs/outputs and precise operating conditions of the algorithms. The entire control system can be subjected to stress tests in this way. Last but not least, the detailed test reports provide

clear information on the maturity status – even at network level. The major benefits for the Outlander project:

- Simple regression tests
- Efficient stress tests on ECU software
- Automated lifetime tests
- Efficient test analysis

The Performance of the dSPACE Virtual Vehicle

The virtual vehicle enables us to validate the quality of the ECU software we develop at a very early stage in the development process. Problematic code can be detected

and identified simply and reliably. Our engineers were very quickly familiar with the system and are convinced of its reliability and quality. We particularly appreciate the flexibility of the ASM simulation models, which are easy to extend by models from suppliers – this was very

“The new virtual vehicle based on dSPACE network simulators enables us to test all the ECU functions, including diagnostic functions, reliably and systematically with a single test system.”

Kunihiro Sakai, Mitsubishi Motors

important to us. The test system from dSPACE gives us very great test depth, and we can also reduce the time required for testing. Overall, we have been able to improve quality and even reduce development time.

Lancer Evolution X and Further Steps at Mitsubishi

The networked simulator we used for the Outlander was flexible enough to simulate other vehicles as well. In particular the HIL system helps us to develop the 6-speed twin clutch “Sport Shift Transmission (SST)” of the all-new Mitsubishi Lancer Evolution X. This is an automated manual transmission that delivers slicker shifting through the gears while freeing the driver from the need to operate the clutch.

In general, to ensure the quality of complex, extensive ECU software in the future, we will continue investing in HIL-based test methods and expand them further. We are convinced that this is an important and necessary step for enhancing the reliability of automotive controls. The dSPACE systems will play a major role in this.

*Kunihiro Sakai
Masahiro Kaneda
Mitsubishi Motors, Tokyo, Japan*

Glossary

Monkey test –

Random activation of switches in arbitrary combinations. Can be compared to the presumed behavior of a monkey sitting in the vehicle.

CVT (Continuously Variable Transmission) –

Allows an infinite variability between highest and lowest gears with no discrete steps or shifts using conical rollers that can be shifted axially.

Web presentation
Lancer Evolution X
<http://www.mitsubishi-motors.co.jp/evolspecial/index.html>

Keeping the Right Speed

As a part of the European research project EASIS, DAF developed a safe speed function for trucks. It helps comply with the legal speed limit by slowing the vehicle automatically if necessary. To analyze and validate the function, DAF used a hardware-in-the-loop simulator from dSPACE in combination with a real steering wheel, pedals, and switches.

- DAF develops safe speed function
- Validation and analysis with dSPACE Simulator
- Part of the European research project EASIS

The EASIS Project

EASIS (Electronic Architecture and System Engineering for Integrated Safety Systems) is a partnership of 22 European vehicle manufacturers, automotive suppliers, tool suppliers, and research institutes. They aim to develop technologies for implementing future safety systems. In this project DAF developed a safe speed function (SSF) for commercial vehicles.



▲ To overtake, the driver overrules the Safe Speed Function.

Safe Speed Function

The SSF software receives traffic information signals and restricts the vehicle speed if the driver requests acceleration above the legal limit. To verify the new function, DAF used a hardware-in-the-loop (HIL) simulator from dSPACE for real-time simulations of a truck and its operating conditions. The test driver used a real dashboard, steering wheel, and pedals and received feedback via a screen showing the simulated truck behavior. The engineers implemented the new functions of the safe speed controller in a dSPACE MicroAutoBox connected to the physical part of the test rack, which contains sensors, ECUs, display, and switches, via a CAN network.



▲ The test driver has a real steering wheel and can see the truck's behavior on a screen.

Driving at Constant Speed

During the tests the SSF is given the speed limit as a traffic signal. If the driver keeps the accelerator pedal pressed to go above this limit, the SSF becomes active and restricts the vehicle to permitted speed. If the truck enters a zone with an even lower limit, the SSF adjusts the speed smoothly and keeps it constant. Full accelerator pedal kick-down means that the driver wants to overtake another vehicle. The SSF is then overruled and the truck can accelerate to a higher speed. When kick-down is released, the SSF reengages and the truck returns to a constant safe speed.



▲ The dSPACE HIL simulator computes the absent truck parts.

For more detailed information on the project, please see the video on www.dspace.com/goto?DAF_SafeSpeedFunction

AutomationDesk is 2.0!

- **Enhanced usability**
- **Numerous innovations**
- **New Sequence Builder**

dSPACE will soon provide a completely new look for AutomationDesk, the test automation software: new features, new user interface options, and above all, enhanced usability. There are numerous new features that make it easier to create and edit extensive test sequences. These include such practical innovations as setting bookmarks, and navigating or zooming in test sequences in the same way as on a map. The technical highlights include enhanced multi-user support and a new offline mode for executing tests without connected hardware or external software.

Not Just a Face-Lift

A quick glance at all AutomationDesk's new icons, shortcuts, and toolbars will tell you that a lot has happened beneath the surface. Many features have been reworked with the aim of enhancing usability. The Sequence Builder, used for developing test sequences graphically, has a new user interface more closely compliant with the UML standard. The block layout has been redesigned to provide greater infor-

mation density and now displays comments, notes, data objects, and data.

Enhanced Navigation and Readability

Also new is the Sequence Builder Overview, giving users a well-organized view of the test sequences. Users can navigate in test sequences in the same way as on a digital map, zooming in and out of sections as required. The new bookmark feature also

makes for easier navigation. Users can place bookmarks on several blocks and simply click to jump from one to the other – even from one sequence to another – for example, if a specific block has to be edited frequently. AutomationDesk's individual panes can now be rearranged as required or even moved out to a second monitor, and users have an additional option for creating their own menu commands.

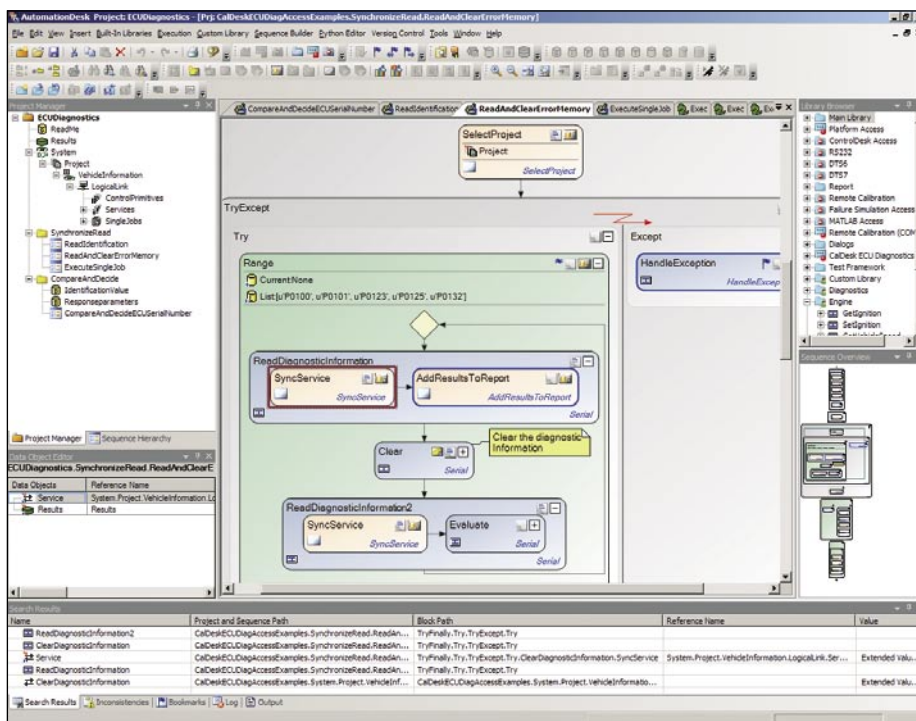

▲ AutomationDesk 2.0's new user interface.

```

34 -----
35 # Class: RTTSequencesEvents
36 # Event class to attach to real-time testing sequences events
37 -----
38 class RTTSequencesEvents(rttmanagerlib.IRTSequencesEvents):
39     def __init__(self, EventSource, Events):
40         # Call base class constructor to connect to event source
41         rttmanagerlib.IRTSequencesEvents.__init__(self, EventSource)
42
43         # Collection of all events
44         self.Events = Events
45
46     def OnError(self, Sequence):
47         """Method OnError"""
48         Sequence = rttmanagerlib.IRTSequence(Sequence)
49         Information = "Stack: %s\nType: %s\nValue: %s" % (Sequence.LastExecutionError,
50         self.OutputEventInformation("OnError", Sequence, Information)
51
52     def OnStateChanged(self, Sequence, NewState):
53
54     def OnWrite(self, Sequence, Output):
55         """Method OnWrite"""
56         Sequence = rttmanagerlib.IRTSequence(Sequence)
57         self.OutputEventInformation("OnWrite", Sequence, Output)
58
59     def OnRemove(self, Name):
60
61     def OnCreate(self, Sequence):
62         """Method OnCreate"""
63         Sequence = rttmanagerlib.IRTSequence(Sequence)
64         self.OutputEventInformation("OnCreate", Sequence.Name, "New RTTSequence: %s" % Sequence.Name)
65
66     def OnResetTestEngine(self):
67         """Method OnResetTestEngine"""
68         self.OutputEventInformation("OnResetTestEngine", "", "Reset test engine.")
69
70     def OutputEventInformation(self, EventName, Sequence, Information):
71         # Output the event information to stdout or trace window
72
73
74
75
76
77
78
79

```

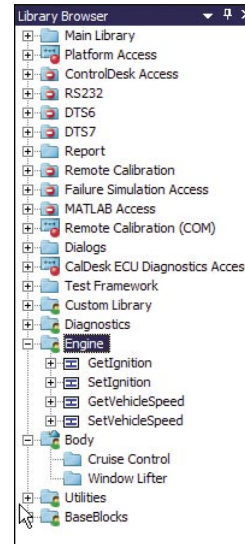

◀ Several user-specific libraries.

▲ Integrated Python Editor with new functions.

New Python Editor

A new multi-instance-capable Python Editor is integrated into AutomationDesk 2.0. This is a convenient means of editing test steps in Exec blocks consisting of Python code. Bookmarks can be used in the new Python Editor in the same way as in the Sequence Builder. Individual sections such as loop or method bodies can be collapsed for better readability during programming work.

Offline Mode for Testing Tests

When AutomationDesk 2.0 is used for test development, test sequences can now be executed “offline” without specific tools such as a calibration and/or diagnostic tool or a hardware-in-the-loop simulator having to be available. Test steps executed in offline mode output default values that were previously defined by the user. The new offline mode supports “test testing” without consuming valuable time on the simulator or requiring licenses for external tools.

Enhanced Multi-User Support

AutomationDesk’s multi-user support has also been extended. For example, it is possible to create several user-specific libraries. Export and import functions let users exchange libraries quickly and easily via e-mail

or network drives. Not only entire AutomationDesk projects can be placed under version control from within AutomationDesk, but also user-defined libraries. Version control systems can be integrated via the Microsoft Source Code Control (SCC) Interface: Suitable systems include Microsoft® Visual SourceSafe, MKS® Source Integrity, IBM® Rational® and ClearCase®. dSPACE also of course provides connection to other systems if required.

Further Innovations

The list of new features continues:

- Consistency checks before test execution
- Extended search function
- Relative paths supported
- Multi-level undo/redo
- User-defined layouts
- Real-time testing with Real-Time Testing 1.3
- Python 2.5 supported

Numerous new features make AutomationDesk even easier to work with. Version 2.0 is a great leap forward, continuing AutomationDesk’s pioneering role as the definitive tool for test creation and automation.

For further information on the release date of AutomationDesk 2.0, please visit www.dspace.com/goto?release

Generating Test Cases Automatically

- Automated testing tool for software and function developers
- Generate test cases based on the TargetLink production code
- Especially high coverage and analysis rates

Embedded in dSPACE's TargetLink tool environment for developing control functions, the new test tool EmbeddedTester™ from OSC - Embedded Systems AG sets another milestone for automated test case generation and code validation. With the TargetLink and EmbeddedTester duo, function and software developers can not only develop and implement functions quite easily and seamlessly from the Simulink® model up to target implementation, but can also perform structured tests and validate the functions at the same time.

Application Area

EmbeddedTester requires TargetLink and is seamlessly integrated in the Simulink/TargetLink development environment. EmbeddedTester supports the entire TargetLink blockset on the one hand, as well as external legacy code on the other. The current version 1.0 of EmbeddedTester can already generate an extremely high code coverage and test objective coverage for any hierarchically developed TargetLink fixed-point code. This has been proven for the past three years in production projects at major manufacturers and suppliers from Germany and Japan. A further development of EmbeddedTester for supporting floating-point applications is being worked on.

Automatic Test Case Generation and Code Validation

On the basis of the production code generated by TargetLink, EmbeddedTester can automatically find input sequences that can cover any kind of defined test objective. For test objectives, EmbeddedTester can also prove if the code is unreachable, up to any desired analysis depth. These two capabilities are guaranteed by special algorithms from the field of formal methods, a well-established application approach for the past 15 years. Thanks to the tight tool integration between EmbeddedTester and TargetLink, scalability is guaranteed even for rather large industrial applications, due to the automatic hierarchical approach. For code coverage criteria such as statement coverage, condition coverage, decision coverage and MCDC

coverage, as well as for production code specific tests with division-by-zero, over- and underflow, type (down)-casting, saturation und relational operations (fixed-point vs. floating-point), automatic test objectives and coverage reports are managed and correspondingly high coverage and analysis rates of up to 100% are reached automatically.

Automatic Test Execution

Due to EmbeddedTester's hierarchic, completely automated test execution method, the complete deterministic test cases, consisting of input signals and monitoring/expectation signals, are created from the automatically generated input sequences. This test execution/simulation can be performed automati-

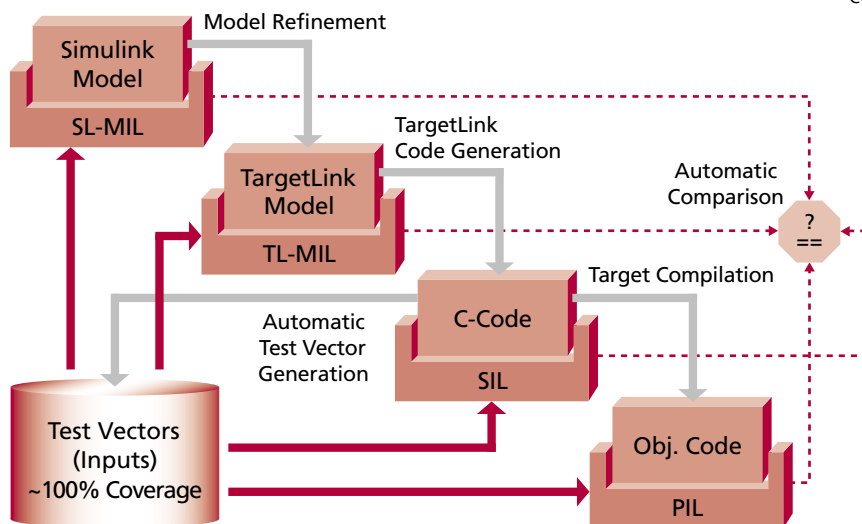

▲ The automatically generated test vectors can be used in all simulation modes and their results can be compared.

cally by EmbeddedTester on any execution level such as Simulink model-in-the-loop (SL-MIL), TargetLink model-in-the-loop (TL-MIL), software-in-the-loop (SIL) and processor-in-the-loop (PIL).

Automatic Test Evaluation

In regression mode, EmbeddedTester automatically compares the next step of the test cases, including the expected values, with all of the levels (SL-MIL, TL-MIL, SIL und PIL) and shows the differences in an automatically generated report. Permitted comparison tolerances can also be defined in EmbeddedTester.

Debugging Support

If differences between the execution levels are discovered, finding the error and correcting it becomes an issue. To do this, EmbeddedTester supports the user with linked coverage reports: with report entries, the points that cause the differences in the target code and in the TargetLink model can be called up with one mouse-click. When doing this, TargetLink and EmbeddedTester work together via a well-defined interface.

Import and Export Interfaces

EmbeddedTester offers the import and export of any number of test cases in and from numerous file formats such as XML, MAT, CSV, etc. This lets the user

Regression Report
Summary: 7 comparisons. 4 succeeded, 3 failed.

simulink path	subsystem name	result
small_sl/small/Subsystem/small	small	

Subsystem small_sl/small

Testvector comparison results

name	length	result
tv_esi_sl_mi3.xml	10	OK
tv_esi_sl_mi22.xml	10	OK
tv_esi_sl_mi4.xml	5	OK
tv_esi_sl_mi23.xml	5	ERROR
tv_esi_sl_mi5.xml	5	OK
tv_esi_sl_mi24.xml	5	OK
tv_esi_sl_mi6.xml	5	OK
tv_esi_sl_mi25.xml	5	ERROR
tv_esi_sl_mi7.xml	4	OK
tv_esi_sl_mi26.xml	4	OK
tv_esi_sl_mi1.xml	1	ERROR
tv_esi_sl_mi27.xml	1	OK
tv_esi_sl_mi2.xml	1	OK
tv_esi_sl_mi28.xml	1	OK

Test Case	Decision
Unique ID	23
File	C:\DOKUME~1\A\alea\LOKALE~1\Temp\atgcv\PRODAS~1\static\codegen\small.c
Line	207
TargetLink Blocks	MinMax(small/Subsystem/MinMax)
Expression	((_cprps_1_Sa3_Sum)<(_cprps_1_Sa4_Sum))
Conditions	
Properties	D:23:0 decision became false reached cCFG2 D:23:1 decision became true unreachable(n) cCFG2

◀ The regression report indicates whether the test case generated an error. The results can be inspected in detail.

reuse already existing test sets from various sources and show them in coverage rates (code coverage) in EmbeddedTester. In the same manner, test cases can also be used which were generated with Embedded-Validator™ on the basis of requirements. Test sequences and the expected values can be exported as a MAT file and reused in dSPACE tools such as AutomationDesk and MTest.

Interview with Hans J. Holberg, Senior Vice President Customer Relations, OSC - Embedded Systems AG:

Mr. Holberg, what problems should EmbeddedTester solve?

Holberg: EmbeddedTester quickly and automatically provides a sufficient number of test cases for a very high structured coverage of models as well as the corresponding code. This prevents untested model and code parts that could lead to problems later on.

What advantages can users expect?

Holberg: Initial experience in production development with EmbeddedTester indicates savings in time of up to 50% for test generation. The analysis and coverage rate can also be raised by 30-40% in most cases, which indicates a significant quality advantage. The debug support functions in EmbeddedTester are also rather important for the user.

What are EmbeddedTester's special strengths?

Holberg: No doubt about it ... automatic test generation with a coverage rate of up to 100%!

Are industrial customers already using this?

Holberg: Yes, MAN Nutzfahrzeuge, Nissan, Hitachi and Ford are already using EmbeddedTester successfully. Numerous evaluations are being made in the automotive and aerospace fields as well.

Why does OSC count on TargetLink?

Holberg: Based on feedback from our customers we have seen during the past 8 years that TargetLink has extremely widespread use. TargetLink is obviously the most often used production code generator in the automobile industry. The decision to match our product to this code generator was therefore quite obvious. Furthermore, TargetLink offers us powerful interfaces and it is excellent for external automation and process integration.



Hans J. Holberg

Hand in Hand

- **SystemDesk and TargetLink**
- **AUTOSAR-compliant development at the system level and function level**
- **Efficient work methods in the production development process**

The aim of the AUTOSAR initiative is to considerably improve the development process for electronic control units (ECUs). Achieving this goal requires efficient interaction between the model-based procedure at the system level introduced in AUTOSAR and the established model-based development at the function level. The system design tool SystemDesk and the production code generator TargetLink, both from dSPACE, complement each other perfectly to provide an efficient model-based method during the production development process.

In the development of AUTOSAR-compliant application software for an ECU, SystemDesk and TargetLink come into play in different phases. The software architecture of an ECU can be specified by means of software components in SystemDesk. TargetLink's strengths lie in filling these components with function models and generating highly efficient production code. As described below, interaction between the two tools can be initiated from both sides.

Architecture-Driven Development

This approach uses the methods proposed in AUTOSAR. It begins by defining an ECU's software architecture at a very early stage in the development process. Using SystemDesk, the architecture is modeled in the form of software components (SWCs) according to the AUTOSAR standard. This also includes specifications of the interfaces and connections between components. Thus, interfaces are compatible from the start, and all the signals required from other SWCs are available. The descriptions of individual SWCs can be used subsequently together with the TargetLink AUTOSAR Module to automatically generate an initial model frame for

developing a new function. Thus, the definitions that were previously prepared in SystemDesk are consistently transferred to TargetLink as interface blocks. As soon as the behavior of the SWCs has been defined by adding the actual controller model to the model frame, AUTOSAR-compatible C code and an extended SWC description can be generated with TargetLink. The results can be transferred back to SystemDesk, where they are checked for consistency and are available for later software integration, including the generation of what is called the Run-Time Environment (RTE).

This sequence can be repeated as required. To manage the AUTOSAR data within TargetLink, it is placed in the dSPACE Data Dictionary, where it can be either imported directly or compared and combined with the data in the existing data dictionary. The imported data is then linked to the actual TargetLink AUTOSAR model.

Function-Driven Development

If an existing function model has to be used in a new AUTOSAR project, the interaction described above can also be initiated from the function view. If the function

▼ *Workflow for architecture-driven development.*

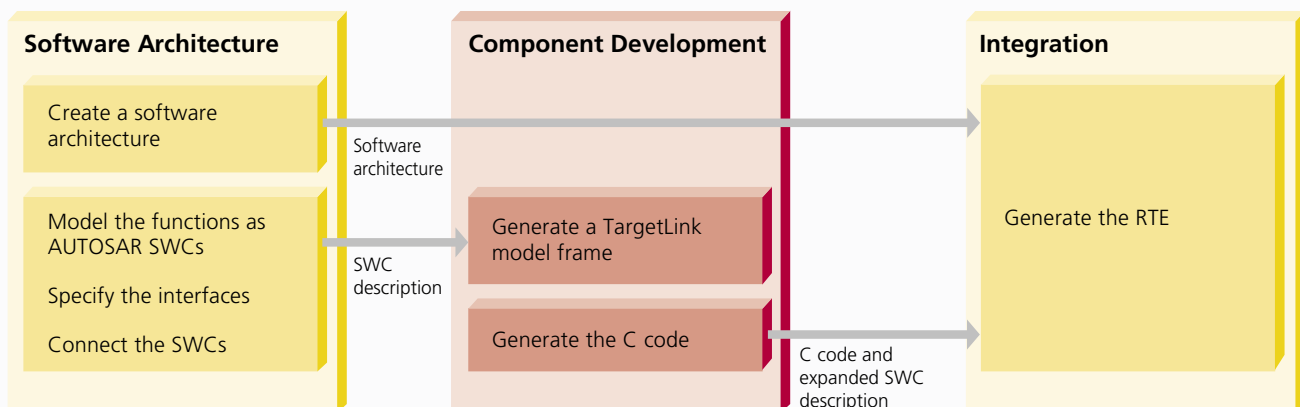

is available in the form of a TargetLink model, it can be migrated by using the TargetLink AUTOSAR Module. The associated data dictionary is used to specify the attributes that each AUTOSAR SWC requires. When the model has been completed, TargetLink automatically generates a component description in the form of an AUTOSAR XML file, in addition to generating the AUTOSAR-compliant C code.

This description can be imported into SystemDesk as a new SWC. It can then be integrated into an overall system by linking it to other components. The interfaces can be checked for compatibility. If they are not compatible, for example because deviating fixed-point scaling was used, the component developers have to adjust the interfaces. The RTE cannot be generated until all SWCs are correctly connected.

Interaction between SystemDesk and TargetLink

The iterative nature of the procedure should be emphasized here: When the software architect changes the SystemDesk model, he or she also creates new versions of the SWC descriptions for the responsible developer. Parts that are different from the old data are indicated

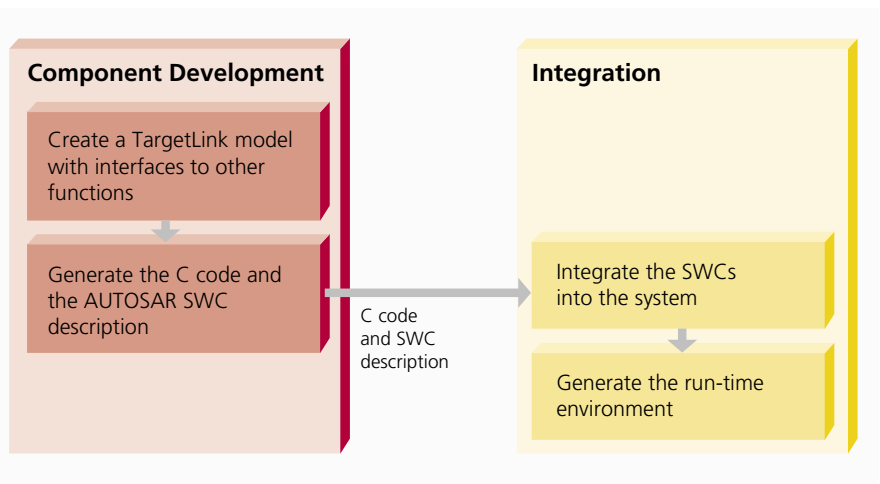

▲ Workflow for function-driven development.

in the dSPACE Data Dictionary Manager. If a developer then creates a new version of the SWC, the SystemDesk model can be updated without important information being lost. For example, the connections between the components and their properties are preserved.

Summary

The system design tool SystemDesk and the production code generator TargetLink from dSPACE are two coordinated tools that allow fast iteration between system

design and component-level function development. SystemDesk and TargetLink support an architecture-driven procedure and also allow previously created function models to be integrated at system level. SystemDesk and TargetLink thus pave the way for the efficient development of AUTOSAR-compliant ECUs.

Further information on SystemDesk and TargetLink: www.dspace.com

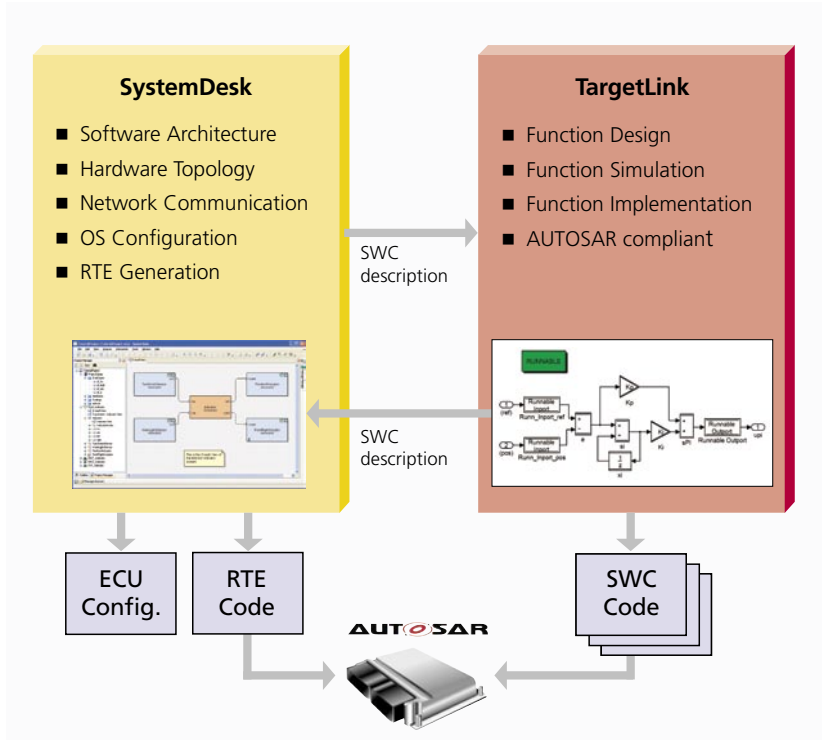

▲ SystemDesk and TargetLink support fast iterations between system design and component development.



5th dSPACE German User Conference

- Intensive expert discussions among users
- The latest trends in developing ECU software
- AUTOSAR Becoming a reality

Many users and product experts met from June 13 - 14, 2007 at Munich for the 5th dSPACE German User Conference. The event focused on papers given by 17 users reporting on their current projects in developing electronic control unit (ECU) software. Other contributions presented the latest trends and developments in the dSPACE product family.

During the course of the conference, various issues became rather clear. It became obvious that at the software development centers of the automobile industry, the development standard AUTOSAR is more than just a buzz word. Thanks to tools such

*"Super conference! Perfect organisation!
I'd love to come again – as a speaker or listener."
Heiko Hägele, ZF Lenksysteme GmbH*

as those produced by dSPACE, it is becoming a reality. The conference also showed that the rapidly increasing number of software functions and their networking is one of the current challenges for the automobile industry. dSPACE meets this challenge with dSPACE SystemDesk, a program that makes the

planning, implementation and integration of complex system architectures and distributed software systems clearly structured and manageable.

The papers on hardware-in-the-loop (HIL) simulation showed that automated ECU test via HIL simulation is becoming more important, and that the role played by AutomationDesk, dSPACE's test automation software, is increasing. Papers on hybrid drives, a topical issue, illustrated how dSPACE tools can be used successfully in production projects, such as in the field of rapid control prototyping. Last but not least, the papers on production code generation once again confirmed that dSPACE TargetLink has now become the standard production code generator for the automobile industry. As usual, you can download all of the speaker's papers from the dSPACE Web site.





Top row of pictures, from left to right:

Welcome by Dr. Herbert Hanselmann, President and CEO, dSPACE GmbH; full assembly with a high-caliber expert audience; intensive discussions during the accompanying exhibition; from users for users: speaker Marcus Engelke, BMW AG.

Bottom row of pictures, from left to right: Reinhard Schieber, AUDI AG, talking with a speaker;

generous breaks allow time for stress-free exchange of ideas; lively jazz with HotSaxClub; evening event at the Deutsches Museum Flugwerft Schleißheim; Jutta Kleinschmidt, the most successful woman in motor sports worldwide.

"The evening program with Jutta Kleinschmidt was definitely a highlight!"

Markus Ritzer, AUDI AG

On the whole, the 5th German User Conference showed once more how highly dSPACE values close contact with its customers. This ongoing exchange of information is extremely important for the continuous further development of the dSPACE product range. This year, as in the past, several participants took the opportunity to ask dSPACE experts detailed questions during the accompanying user forums. This exchange of experience continued during the intensive conversations during the breaks. Various dSPACE partners participated in the exhibition with

"In light of the papers, and especially the atmosphere, a very interesting and pleasant conference."

Marcus Engelke, BMW AG

live demonstrations and product presentations. The quality of the evening program of this year's German User Conference was as excellent as that of the papers: after the first day, the participants went directly to the Deutsches Museum Flugwerft Schleißheim.

One of the highlights of the evening event was the speech delivered by Jutta Kleinschmidt, the most

"The conference was quite worthwhile for me. I had interesting and helpful conversations with users and product managers."

Franz Gunnar Grein, MAGNA STEYR Fahrzeugtechnik AG & Co KG

successful woman in motor sports worldwide. She captured the crowd with exciting stories of her adventures in desert rallies.

We would like to thank all the speakers, participants, and partners for helping to make the 5th dSPACE German User Conference such a success.



2nd Japanese User Conference

➤ **dSPACE Japan K.K. invited to 2nd user conference**

➤ **Customer use case presentations**

➤ **Stimulating discussion at the exhibition**

After its foundation only last year, dSPACE Japan K.K. held its second user conference on June 22, 2007. Many customers accepted the invitation to meet other users and compare notes.

Following the many positive comments made about the last event, customers were again invited to compare notes and catch up on the latest product innovations. 242 customers from 95 different companies took the opportunity and met at the Westin Hotel Tokyo on June 22. The keynote speaker was Dr. Kiichiro Tamaru from the Information-technology Promotion Agency (IPA), Independent Administrative Institution. He presented the work on developing highly reliable embedded software, particularly automobile software, carried out at the IPA's Software Engineering Center (SEC). The SEC is run jointly by industry and university and promoted by the Japanese Ministry of Economy, Trade and Industry. One of its objectives is to enhance cooperation between industry and university.

- "Integrated Test of ECUs with HILS" by Kunihiro Sakai, Mitsubishi Motors
- "Establishment of Model-Based Development Environment in DENSO" by Manji Suzuki, DENSO
- "New Motion Control of Electrical Automobiles" by Dr. Hiroshi Fujimoto, Graduate School of Engineering, Yokohama National University

Exhibition

On display were demonstration systems showing how the dSPACE products work and how they are handled. The participants showed great interest in the hardware



▲ The exhibition was the ideal place for lively discussions and detailed examination of products.

Customer Use Case Presentations

The customer use case presentations attracted a lot of attention, as they gave insights into the challenges and solutions in various projects.



▲ The customer use case presentations attracted a lot of attention.



and software demo systems. Many lively discussions took place between dSPACE application engineers and customers, to the benefit of both.

The second user conference ended with a great end-of-conference party. dSPACE Japan K.K. would like to thank all the participants and hopes to see them again next year.

Reader Survey

Your Opinion of dSPACE NEWS?

We want dSPACE's customer magazine to be how you want it to be. So to help us, please let us know your opinion. As a thank you, everyone who participates automatically enters a prize drawing for one of three € 50 vouchers for online mail order company Amazon. The vouchers will be issued in the local currencies of the winners.

Your opinion.



TERMS AND CONDITIONS

The closing date is December 31, 2007. Anyone over 18 years of age can participate except for dSPACE employees and their relatives. There will be no cash payments. Each participant has only one

It couldn't be easier:

Just use the online questionnaire on our Web site at www.dspace.com/goto?R07 Or you can fill out the enclosed questionnaire and return it to dSPACE by fax or mail.

Online questionnaire
www.dspace.com/goto?R07

Your gain.



unique chance of winning. The decision of the prize draw supervisor is final. The winners will be notified in writing and announced on our Web site.

dSPACE Inc. Keeps Growing

dSPACE Inc. officially unveiled its new North American headquarters on July 27, 2007. Employees, customers, business partners and city officials gathered in the lobby of the newly renovated, 35,000 square-foot, 2-story building located in the City of Wixom, Michigan, to celebrate the occasion with a ribbon-cutting ceremony and a champagne toast. An open house followed, complete with building tours, product demonstrations and a catered luncheon. The new facility includes an expanded laboratory for production and development and a dedicated garage for customer vehicle testing. Additionally, a product demonstration room and an improved training room were added to better serve the needs of dSPACE Inc. customers. The decision to relocate dSPACE Inc. into a larger facility was made after the subsidiary experienced a staffing increase of 30% in 2006. The relocation represents the fourth move for dSPACE Inc. since the early 1990s. The new building will accommodate dSPACE Inc.'s existing 40-person staff and provide for future expansion.



▲ dSPACE GmbH CEO Herbert Hanselmann (left) and Bruce Birgbauer (right) of Miller Canfield assist dSPACE Inc. President Kevin Kott (middle) with the ceremonial cutting of the ribbon to open the new facility.

dSPACE Inc.
50131 Pontiac Trail
Wixom, MI, USA 48393-2020

For further information on the event, please see www.dspace.com/goto?open_house

Japanese Subsidiary Opens Branch Office

dSPACE Japan K.K. opened a branch office in the prefecture of Aichi on July 19, 2007. Technical staff and sales engineers are now located in close proximity to customers, so they can respond to inquiries faster and more flexibly. Shorter distances mean very direct and intensive consultation and also better support for urgent projects.

Staff at headquarters also had to relocate due to rapid growth. They moved to a larger building on August 27.

New addresses for dSPACE Japan K.K.:

dSPACE Japan K.K.

10F Gotenyama Trust Tower
4-7-35 Kitashinagawa Shinagawa-ku
Tokyo 140-0001
Tel: +81 3-5798-5460
Fax: +81 3-5798-5464



Nagoya Facility

7F Nagoya Nishiki Daiichiseimei Bldg.
1-6-5 Nishiki Naka-ku Nagoya-shi
Aichi 460-0003
Tel: +81 52-220-5155
Fax: +81 52-220-5156



dSPACE Tool Chain Supports Python 2.5.1

As of Release 6.0, the dSPACE tool chain will support Python 2.5.1, the new version of this programming language. Python is used especially in the field of test automation to create individual test steps or comprehensive scripts. By switching to Python 2.5.1, it is now possible to use the newest versions of freely available

libraries and to profit from the most up-to-date functions and bug fixes. For reasons of compatibility, the dSPACE libraries will continue to be supplied in the previous version, Python 2.2. (exception: Real-Time Testing 1.3).

www.python.org/2.5.1



dSPACE Software Supports Windows Vista

New dSPACE software versions from dSPACE Release 6.0 support Microsoft Windows Vista 32. With continuing support for Windows 2000 and Windows XP, dSPACE now covers the most frequently used operating systems.

The first Vista-compatible programs are:

- AutomationDesk
- ControlDesk
- ConfigurationDesk
- ModelDesk
- MotionDesk

Vista compatibility will be added to the remaining software step-by-step as new product versions are released.

For further information on the contents and release date of dSPACE Release 6.0, visit 6.0 www.dspace.com/goto?release

Events



dSPACE participates in trade fairs and conferences throughout the world. Come to one and get to know us and our solutions. We're looking forward to meeting you!

For the dates, visit www.dspace.com

Request Infos



Please check the appropriate field on your response card and return it

- /// By mail
- /// By fax to +49 52 51 – 6 65 29
- /// or request information via our Website www.dspace.de/goto?dspace-news-info

Your opinion is important. Please send your criticism, praise, or comments to dspace-news@dspace.de – thank you!

Job Opportunities



Are you an engineer who is just graduating? Or are you looking for new professional challenges? Then come and join our team in Paderborn, Munich or Stuttgart, Germany; Paris, France; Hertfordshire, United Kingdom or Wixom, MI, USA!

Due to our continuous growth, dSPACE is looking for engineers in

- /// Software development
- /// Hardware development
- /// Applications
- /// Technical sales
- /// Product management

Current offers at www.dspace.com/goto?jobs

Trainings



- /// dSPACE Real-Time System
- /// RTI CAN MultiMessage Blockset
- /// ControlDesk
- /// TargetLink
- /// Hardware-in-the-Loop Simulation
- /// ASM Vehicle Dynamics
- /// ASM Engine Dynamics
- /// AutomationDesk
- /// Real-Time Testing
- /// CalDesk
- /// RapidPro
- /// Rapid Control Prototyping with CalDesk

For more information, please visit www.dspace.com/goto?training

Papers



“SystemDesk and TargetLink – AUTOSAR-Compliant Development at System and Function Level”

Dipl.-Math. Michael Beine, Dr.-Ing. Ulrich Eisemann, Dr. rer. nat. Dirk Stichling, dSPACE GmbH

“Seamless Tool Support in the Test Process for ECU Development”

Dr. rer. nat.-Inf. Sven Burmester, dSPACE GmbH

For more information, please visit www.dspace.com/goto?info_downloads

Australia

CEANET Pty Ltd.
Level 5, 15 -19 Bent Street
Sydney NSW 2000
Australia
Tel.: + 61 2 9232 3699
Fax: + 61 2 9232 3332
info@ceanet.com.au
www.ceanet.com.au

China and Hong Kong

HiRain Technologies
8F Tower B
Beijing Venture Plaza No.11
Anxiang Beili Chaoyang District
Beijing China, 100101
Tel.: +86 10 648 40 606
Fax: +86 10 648 48 259
xmcao@hirain.com
www.hirain.com

Czech Republic and Slovakia

HUMUSOFT s.r.o.
Pobrezni 20
186 00 Praha 8
Tel.: +420 2 84 01 17 30
Fax: +420 2 84 01 17 40
info@humusoft.cz
www.humusoft.cz

India

Cranes Software Intern. Ltd.
#29, 7th Cross, 14th Main
Vasanthnagar
Bangalore 560 052, India
Tel.: +91 80 4151 6400
Fax: +91 80 4151 6500
dspace@cranessoftware.com
www.cranessoftware.com

Korea

MDS Technology Co., Ltd.
15F Kolon Digital Tower Vilant 222-7
Guro-3-dong, Guro-gu
Seoul 152-848, South Korea
Tel.: +82 2 2106 6000
Tel.: +82 2 2106 6004
Fax: +82 2 2106 6004
dspace@mdstec.com
www.mdstec.com

Netherlands

TSS Consultancy
Rietkraag 37
3121 TC Schiedam
Tel.: +31 10 2 47 00 31
Fax: +31 10 2 47 00 32
info@tsscon.nl
www.tsscon.nl

Poland

Technika Obliczeniowa
ul. Obozna 11
30-011 Kraków
Tel.: +48 12 630 49 60
Fax: +48 12 632 17 80
info@tobl.com.pl
www.tobl.krakow.pl

Sweden

Fengco Real Time Control AB
Svärdvägen 25A
SE-182 33 Danderyd
Tel.: +46 8 6 28 03 15
Fax: +46 8 96 73 95
sales@fengco.se
www.fengco.se

Taiwan

Scientific Formosa Incorporation
11th Fl. 354 Fu-Hsing N. Road
Taipei, Taiwan, R.O.C.
Tel.: +886 2 2505 05 25
Fax: +886 2 2503 16 80
info@sciformosa.com.tw
www.sciformosa.com.tw

Headquarters in Germany

dSPACE GmbH
Technologiepark 25
33100 Paderborn
Tel.: +49 52 51 1638-0
Fax: +49 52 51 66529
info@dspace.de

United Kingdom

dSPACE Ltd.
Unit B7 · Beech House
Melbourn Science Park
Melbourn
Hertfordshire · SG8 6HB
Tel.: +44 1763 269 020
Fax: +44 1763 269 021
info@dspace.ltd.uk

France

dSPACE Sarl
Parc Burospace
Bâtiment 20
Route de la Plaine de Gisy
91573 Bièvres Cedex
Tel.: +33 1 6935 5060
Fax: +33 1 6935 5061
info@dspace.fr

Japan

dSPACE Japan K.K.
10F Gotenyama Trust Tower
4-7-35 Kitashinagawa
Shinagawa-ku
Tokyo 140-0001
Tel: +81 3 5798 5460
Fax: +81 3 5798 5464
info@dspace.jp

USA and Canada

dSPACE Inc.
50131 Pontiac Trail
Wixom · MI · USA 48393-2020
Tel.: +1 248 295 4700
Fax: +1 248 295 2950
info@dspaceinc.com

