

Electronic load emulator for HIL simulation at power level now also available for high-powered electric motors



Full Power



dSPACE has been using electronic load simulations for the hardware-in-the-loop (HIL) simulation of small-sized electronic motors, such as those used in electrical steering systems, for several years. Now the new electronic load emulator is ready to push the power range up considerably. So large drive motors in hybrid or electrical vehicles can now be simulated at the electrical power level.

Simulating an Electric Motor at Power Level

If the HIL tests for an electrical drive system have to include the power stages, testing at signal level is not enough. One way is to operate a real drive motor on a test bench; but another option is to simulate the electric motor at the electrical power level (figure 1). This involves simulating the electrical behavior of a real motor by mapping the real

terminal voltages and currents and feeding them to the ECU. Compared with a mechanical drive test bench, a purely electrical test bench of this kind is easier and safer to operate. Tests can be run at a very early stage, even if the real drive motor is not yet available. Moreover, it is also possible to simulate different motor types. Unlike mechanical test benches, these simulators have no restrictions on dynamic processes.

The new electronic load emulator covers voltages of more than 600 V and power outputs of up to 100 kW. Thus, it is suitable for the HIL simulation of current and future electrical drive systems.

How the Electronic Load Emulator Works

The electronic load emulator emulates the variable, active parts of the voltages u_{EMK} induced in the motor

coils, while the inductive behavior of the motor coils is represented by equivalent substitute inductivities L_{Motor} . The induced voltages u_{EMK} are calculated in real time by an electric motor model and implemented by the electronic load simulator.

How the Electronic Load Emulator is Implemented

The load emulator uses inverters from the ServoOne series by LTI. The electric motor model for computing the induced voltages is implemented on a dSPACE real-time system by means of Simulink®. The model components that can be simulated include the drivetrain. Various sensor and actuator simulations are added to the real-time system for this, according to project-specific requirements. A hybrid ECU requires at least one appropriate simulation of an engine speed sensor (such as a resolver).

Applications

The concept of the electronic load emulator can be used for simulating all types of motor. The physical properties of each motor, such as motor inductivity, torque generation

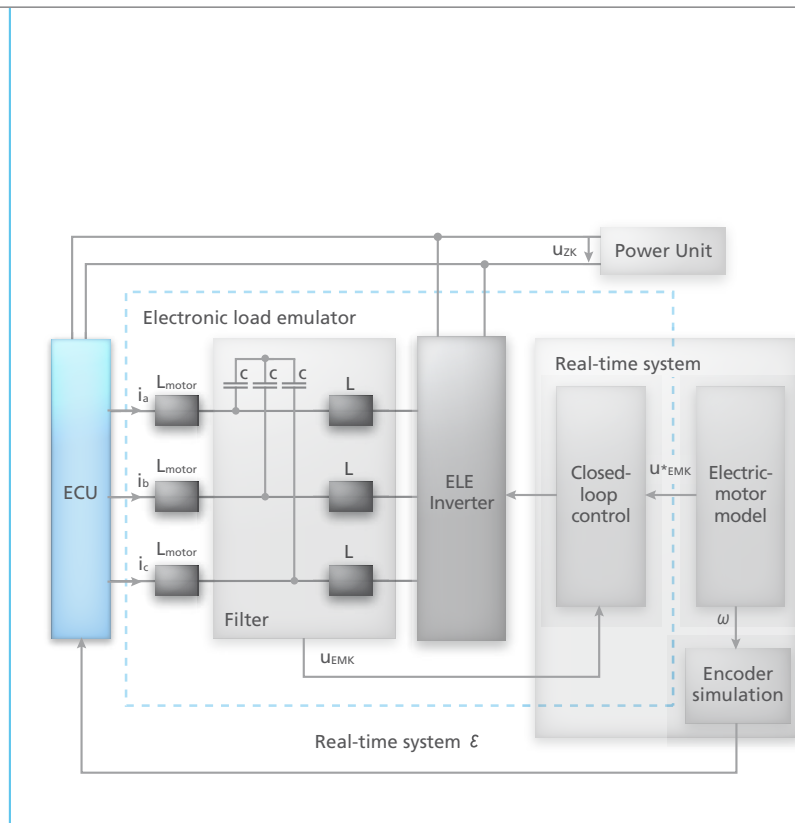

Figure 2: Overall HIL system with electronic load emulator. (ELE = Electronic Load Emulation, EMF = Electromotive Force)

and power consumption are represented very realistically. For variable inductivities (such as in an interior permanent magnet, IPM motor or with saturation effects), mean values have to be used in the load emulator due to the constant substitute inductivities. Nevertheless, correct representation of the torque and the

power is possible. Any desired hybrid and electrical vehicle configurations can be simulated by using different electric motor models in conjunction with variable drivetrain models (for example, Automotive Simulation Models or ASMs). The concept is also suitable for various industrial HIL applications. ■

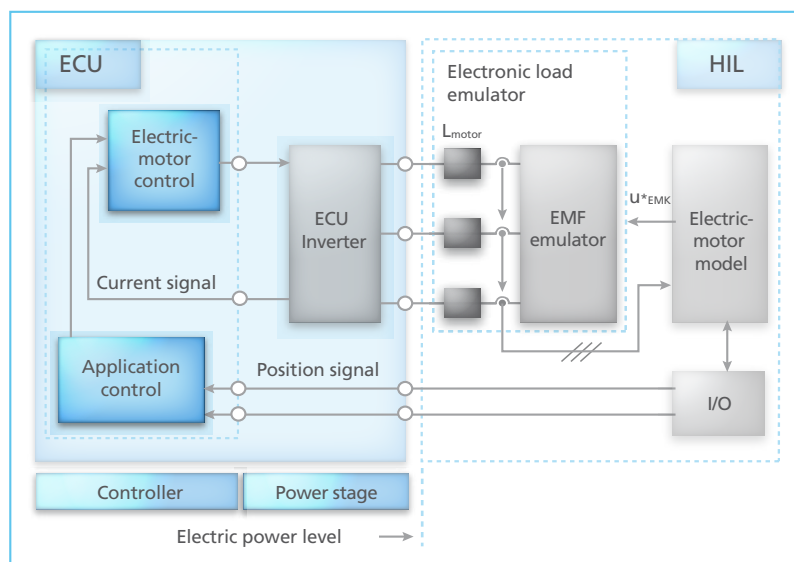

Figure 1: Electronic load emulator for simulating an electric motor at the power interface.

Conclusion

The new generation of electronic loads means that solutions for the HIL simulation of electrical drive motors are now available. They can be used anywhere where flexible, comparatively easy-to-use simulation at power level is important, but the use of an expensive mechanical motor test bench needs to be avoided.