

# HIL for a Three-Wheeler Scooter

➤ **Piaggio MP3 scooter with two front wheels**

➤ **HIL simulation at ELASIS**

➤ **Test automation with AutomationDesk**

Piaggio developed the three-wheeler scooter MP3 with two front wheels. The two independent and balancing wheels on the front suspension assembly frame provide greater dynamic stability performance than a standard scooter. The innovative, electronically controlled locking system keeps the vehicle upright without using the usual central stand. The complete system of networked electronic control units (ECU) was tested by ELASIS using a dSPACE hardware-in-the-loop (HIL) simulator.

## Three-Wheeler Scooter

Ordinary scooters with two wheels are a little bit instable, and you have to be very careful while driving on slippery road surfaces. Our new three-wheeler scooter MP3 with two front wheels has great advantages in terms of maneuverability and safety, due to better road holding in whatever grip conditions and on bad surface roads. It has a parallelogram suspension anchored to the frame that allows a tilt angle of up to 40°. The locking mechanism for the front suspension mainly consists of the NST (Nodo Stazionamento, Locking Mechanism Control Unit) and the engine control unit NCM (Nodo Controllo Motore). The implementation of the NST is feasible only if the electronic control unit (ECU) which controls it is connected to the NCM via a CAN network

▼ *The parallelogram suspension holds the two front wheels.*

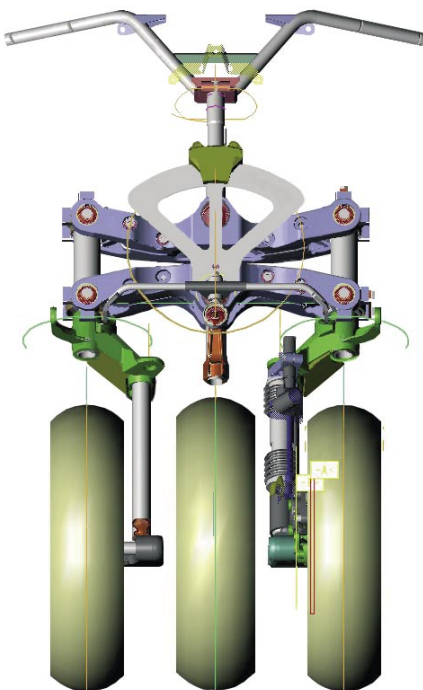

## Upright Without Kickstand

Our new locking system NST allows “easy parking” without the kickstand, even on an inclination or with a difference in height of up to 20 cm between the two front wheels. When the pilot pushes the lock request lever, the lock conditions have to be simultaneously verified:

- Vehicle speed below a threshold which is a function of vehicle deceleration
- Throttle closed and engine speed under a threshold

If these conditions are not reached after a certain time span, the lock request is



▲ *The three-wheeler MP3 scooter from Piaggio.*

rejected. If the locking conditions are true, a lamp on the dashboard starts flashing and is lit permanently when the suspension is locked.

When the driver is on the scooter, the suspension is unlocked on the driver's request and, for safety reasons, if one of the following conditions is verified:

- Engine speed above a threshold which assures that the clutch is closed
- Vehicle speed above a threshold

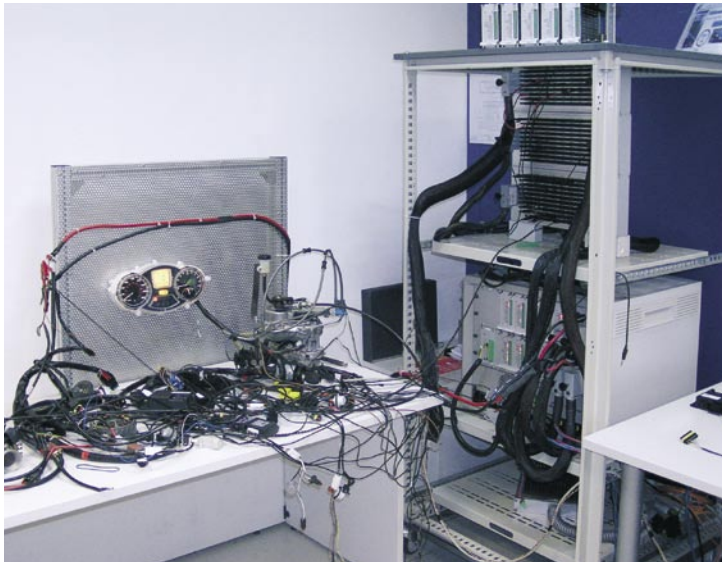

▲ The hardware-in-the-loop setup with a dSPACE Simulator Mid-Size.

**Simulation with dSPACE Simulator**

To test the NST thoroughly, we needed a lot of severe testing conditions that are difficult or even dangerous to reach, like cornering sharply or braking at top speed on rain-soaked surfaces. Moreover, it is almost impossible to generate exactly the same testing condition twice. We tested the NST and the NCM simultaneously on the CAN network. The model of the engine runs in real time to verify correct control system integration on the CAN network. The simulation therefore had to provide a short turn-around time. We also needed a test platform with closed-loop simulation, the facility for test automation, and fault insertion (FIU) capabilities. To make sure the locking mechanism will be reliable even if other components fail, FIU is very important. Having this in mind

*“Testing on an HIL platform accelerated our verification and validation process significantly.”*

**Ferdinando Ferrara, ELASIS**

and working towards extending the same development platform for different ECUs, we at ELASIS selected a dSPACE Simulator Mid-Size as real-time hardware. We built the model for the scooter behavior in MATLAB®/ Simulink® and computed it with a DS1005 PPC Board. The I/O signals were generated and measured by the DS2210 HIL I/O Board, which also performed the signal conditioning. This board contains special functions for generating and reading ECU crank-angle-based signals with high accuracy and convenience.

**Test Automation**

After the HIL platform was completely functional, test automation played a crucial role by allowing us to do lights-out testing on the ECU. For defining these test patterns and organizing the results, we used AutomationDesk from dSPACE.

In later stages of development, we used the HIL simulator as a validation tool to evaluate any change to the already developed software. In the final part of development dSPACE Simulator’s test automation ability was very important, because this allowed repeatable execution of test sequences to

ensure that changes in one area do not affect functions elsewhere.

*Ferdinando Ferrara, Massimiliano de Manes, ELASIS Pontedera, Italy*

*Edoardo Ruggiero, Piaggio Pomigliano d’Arco, Italy*



▲ The MP3 provides a tilt angle of up to 40°.