

dSPACE

NEWS

FACTS · PROJECTS · EVENTS

Customers

**DENSO –
CalDesk Optimizes
Collision Warning**

**Hispano-Suiza –
Thrust Reversal
for Airplanes**

VW – The Driverless Car

**Siemens VDO –
Wedge Brake in Action**

Products

**SystemDesk –
Brand-New
Architecture Tool**

**Porsche – Virtual Manual Transmission
with dSPACE Real-Time Hardware**

A red Porsche sports car is shown driving on a winding asphalt road that curves through a lush, green, hilly landscape. The car is in the foreground, moving towards the viewer and slightly to the right. The background shows rolling hills and dense vegetation under a clear sky. The car's license plate is visible and reads 'S GO 4040'.

Editorial

- 3** By Dr. Herbert Hanselmann,
President

Customers

- 4** Siemens VDO: Intelligent
Wedge Brake
- 6** DENSO: CalDesk for Adaptive
Cruise Control
- 8** Fiat Auto: Testing Diagnostic Capability
- 10** Hispano-Suiza: Braking at Full Speed
- 12** University of Adelaide: EDGAR –
Self-Balancing Scooter
- 14** Porsche: Virtual Manual Transmission
- 16** SterlingTech: Bypassing The
Heart's Control
- 18** Volkswagen: Golf GTI 53⁺¹ –
The Driverless Car
- 20** University of Duisburg:
The Robot's Net
- 22** Ford Aachen: Fiesta with
Micro Hybrid Drive
- 25** EASIS: Architectures for Safety

Products

- 28** Production Projects Under Control
(SystemDesk)
- 30** Bypassing with CCP
(RTI Bypass Blockset 2.2)

- 32** Variable Editing Made Easy
(Variable Editor)
- 34** Single-Source Testing and Diagnostics
(AutomationDesk)

Business

- 35** Innovations in Release 5.2
- 35** TV Summer 2006
- 36** French User Conference
- 38** Compact News
- 39** Info and Dates

dSPACE NEWS

dSPACE NEWS is published periodically by:

dSPACE GmbH · Technologiepark 25
33100 Paderborn · Deutschland
Tel.: +49 52 51 16 38-0 · Fax: +49 52 51 6 65 29
dspace-news@dspace.de · info@dspace.com
support@dspace.de · www.dspace.com

Project Manager and Author: André Klein
Technical Authors: Alicia Alvin, Bettina Henking-Stuwe,
Ralf Lieberwirth, Sonja Lillwitz, Julia Reinbach,
Dr. Gerhard Reiß, Klaus Schreiber
Co-Workers on this issue: Susanne Köhl
Editors and Translators: Robert Bevington, Stefanie Bock,
Christine Smith
Layout: Beate Eckert, Tanja Raeisi, Sabine Stephan

© Copyright 2007

All rights reserved. Written permission is required for reproduction of all or parts of this publication. The source must be stated in any such reproduction. This publication and the contents hereof are subject to change without notice. Brand names or product names are trademarks or registered trademarks of their respective companies and organizations.

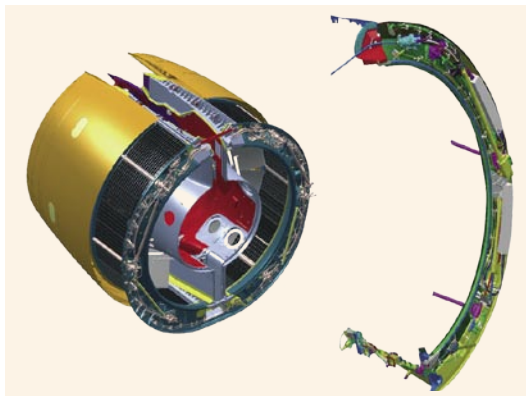

- 10** *Hispano-Suiza, a company in the SAFRAN group, used a dSPACE prototyping system to develop the ETRAS® (Electrical Thrust Reverser Actuation System) thrust reversal system for the Airbus A380.*



- 12** *EDGAR (Electro-Drive Grav-Aware Ride) is a self-balancing, two-wheel scooter developed by mechatronics students at the University of Adelaide using the DS1104 R&D Controller Board from dSPACE.*



I find it interesting to see how new tools first solve problems, and then after a while give rise to new tasks.

One example was rapid control prototyping. The more it speeded

up the development process, the more the transition to production code looked like a bottleneck. Function developers were able to produce far more designs and wanted to make quick-turnaround changes in the models even at later stages of the development process. The old method of manual code implementation was therefore no longer acceptable, and automatic code generation became imperative.

Code generation then not only enhanced quality, it also boosted productivity, which was essential in view of the increasing demands being made on electronics systems. Now automotive software contains so many function modules interacting both inside each electronic control unit and in the network, that it was inevitable that the focus moved to the software and system architecture.

For lack of suitable tools, some users soon tried to tackle architecture issues with tools that were really designed for developing individual, separate control

functions and algorithms. It was hardly surprising that these left much to be desired. Defining, describing, and implementing software architectures require different, additional approaches. It was a logical next step for us at dSPACE to do something about that. We already had close experience of this issue, with TargetLink. We also know how to handle communication data, and we know AUTOSAR, where we were and are active in the field of software component templates and others.

Our new tool, SystemDesk, takes our support for automotive software development to a new level. SystemDesk speaks the language of architecture and system designers. It handles both the early functional system models produced by OEMs, and the implementation-close architecture models often used by suppliers. SystemDesk supports the AUTOSAR standard, but it is just as possible to work with SystemDesk without it. Used in conjunction with TargetLink, SystemDesk provides an integrated solution for developing ECU software.

You can get a first impression from the SystemDesk article in this issue of dSPACE NEWS. With SystemDesk, we have laid the foundations for our customers to continue optimizing their development processes in the future, and keep software complexity under control with a tailored toolset which is designed for production software development.

*Dr. Herbert Hanselmann
President*

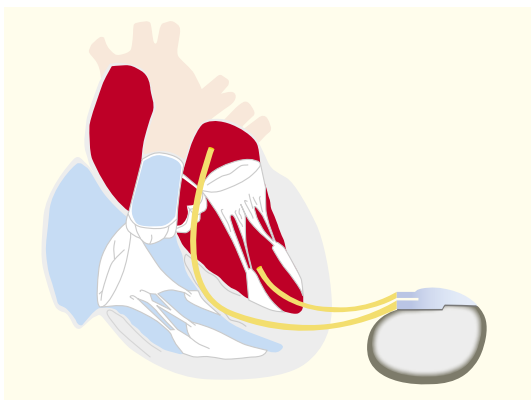

16 *SterlingTech uses a dSPACE prototyping system to help to develop patented sensors for a pacemaker to improve the measurement and control of blood flow through the heart.*

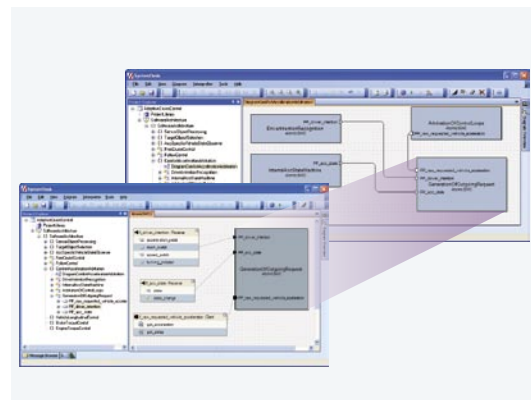

28 *SystemDesk support for the model-based development process starts at system level. It is especially suited for implementing, and integrating software architectures, and for distributed software systems.*

Intelligent Wedge Brake

- **Siemens VDO Automotive develops electronic wedge brake**
- **By-wire control system developed using FlexRay tools from dSPACE**
- **Passed test drives with excellent results**

Test drives have shown the new electronic wedge brake from Siemens VDO Automotive to have excellent braking performance. Experts rate the dynamics and deceleration particularly highly. This is sophisticated technology, and handling it requires powerful control systems. Among the tools that Siemens VDO Automotive is using to develop the systems and test them in a real vehicle is a modular dSPACE prototyping system, which controls the brakes. dSPACE's FlexRay tools are used to develop the FlexRay network for the entire brake system.

At Siemens VDO Automotive, we are currently developing a new generation of brakes, which will go into production by 2010. The idea behind brake-by-wire technology, which was first presented in 2005, is to do without any hydraulic brake components whatsoever. This will enable future driver assistance systems to access the brakes faster and more accurately, so automobile manufacturers will be able to implement shorter braking distances, even on ice and snow.

How the Brake Works

The basic idea behind the electronic wedge brake (EWB) is to convert the vehicle's own kinetic energy into a braking force. During braking, a brake pad connected to a wedge is pressed between the brake caliper and the brake disk. The rotation of the wheel, which is driven by the vehicle's kinetic energy, automatically amplifies the wedging effect. Thus, a very

large braking force can be generated with very little effort. An intelligent control system prevents the brake wedge from jamming. The EWB's particular advantages are its fast responses, especially in ABS mode, and constant braking pressure at low energy consumption.

Cascaded Control System with FlexRay Network

Every brake module in the vehicle is equipped with intelligent electronics that control the actuators. A central electronic control unit (ECU) executes the higher-level control strategy. The brake modules are connected in a FlexRay network. In the prototyping phase, a dSPACE prototyping system acts as the central ECU. This executes the four brake controllers and an ABS/ESP controller, while the motor controllers for the wedge motors run on the brake modules. The

► *The principle: When the wedge brake is open, the brake disc rotates freely, and the wheel is unbraked. When the wedge brake is applied, it utilizes the wheel's own motion. A slight change in wedge position therefore effects a high braking pressure on the brake disk.*

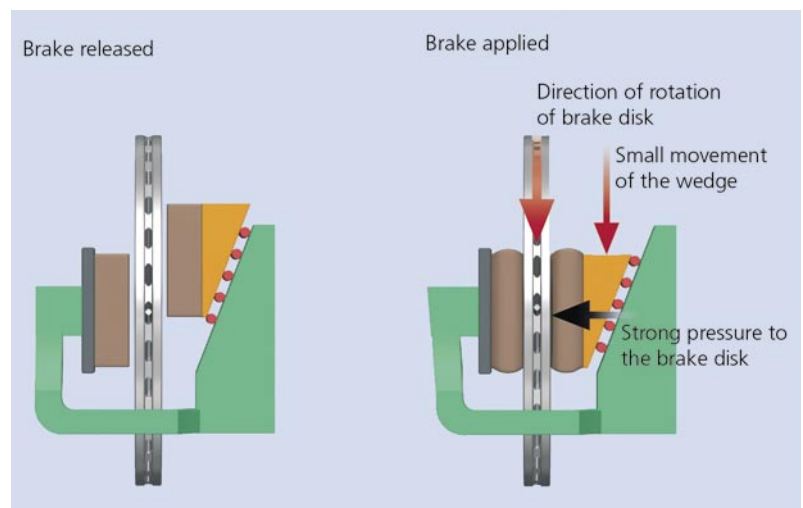

highly dynamic brake controllers are implemented on the dSPACE prototyping system with a cycle time

“The dSPACE development system was not only hard-worked with regard to data throughput and flexibility, but also tested successfully for reliability under extreme mechanical conditions in test drives.”

Bernd Gombert

of 700 μ s, producing a correspondingly high data transmission rate between the dSPACE prototyping system and the brake modules with the wedge motor controllers.

Efficient Function Prototyping with FlexRay

We use the RTI FlexRay Blockset to extend the function model of the brake controller that we developed. This allowed the model to be mapped to the controller topology quickly and reliably. The computation-intensive controller model calculation and FlexRay communication both have to be performed within the short cycle time of 700 μ s. This is achieved by a DS1005 multiprocessor system, whose high processing power and low I/O latencies ensure both complete controller computation and deterministic transmission of FlexRay data. The processor boards are installed in a Tandem-AutoBox together with DS4501 FlexRay Interface Boards and DS4302 CAN Interface Boards. This allows it to be used in the actual test vehicle. The DS1005 system is connected with the vehicle’s CAN bus via the CAN

► *Design of the real test vehicle with FlexRay bus: All four wheels have electronic wedge brakes that are controlled via a central prototyping ECU installed in the AutoBox.*

Interface Board, for example, to use sensor data (such as lateral acceleration) or to send ESP requests for torque reduction to the engine ECU.

Successful Test Drives

When the braking force is applied and removed at sufficient speed, using a hydraulic pressure gradient of max. 5800 bar/s for pressure build-up and max. 2000 bar/s for pressure release, with precision control of the braking force, the wedge brake is able to perform ABS and ESP interventions very effectively. The first test drive period put the brake’s performance and stability to the test, including extreme climatic conditions and difficult ground. The ABS/ESP functionalities tested successfully on road surfaces with both high and low friction, and the robustness of the brake under high mechanical and thermal stress was investigated. The dSPACE system also passed this test under high mechanical stresses, without any failures.

*Juliana Baron,
Bernd Gombert,
Siemens VDO Automotive, Siemens AG,
Regensburg, Germany*

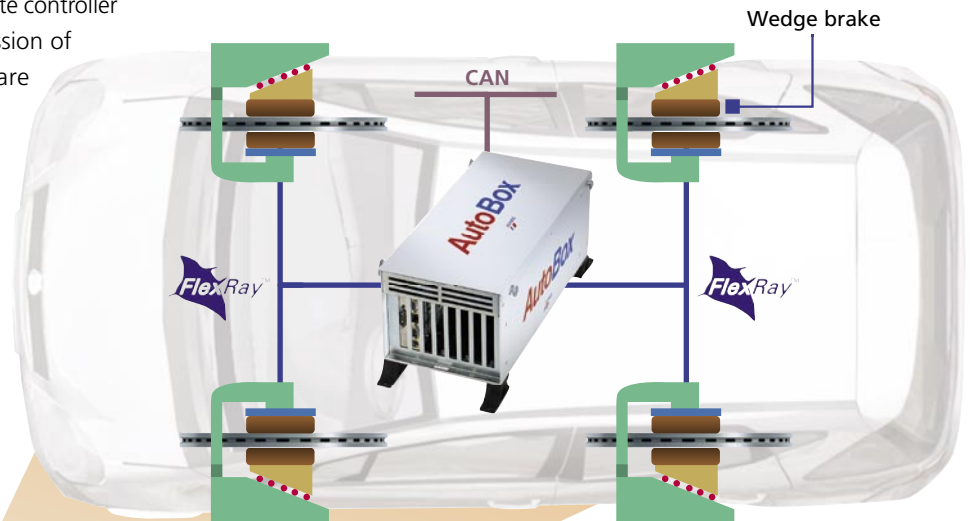

◀ *Test drives with the wedge brake prove that the innovative by-wire system was implemented successfully. A dSPACE prototyping system is installed in the test vehicle and proves to be a robust, high-performance system.*

CalDesk for Driver Assistance Systems

- Driver assistance systems developed with dSPACE tools
- Measurement, calibration, and bypassing tasks in parallel
- Convenient tool environment and minimized workload

For the development of Pre-Crash and Adaptive Cruise Control, DENSO CORPORATION uses an environment with several dSPACE tools. CalDesk, the universal measurement and calibration software, is the heart of the setup and provides parallel access to ECUs and MicroAutoBox, which is used for calculating new functions in bypass mode. CalDesk also has an ASAM-MCD 3 COM interface to provide direct data exchange with DENSO's software tool for evaluating video and radar data. The tool environment enables DENSO to perform measurement, calibration, and bypassing tasks with a minimized workload.

Driver Assistance Systems

It happens every day: Traffic is congested, and when a vehicle changes lane, it encroaches into the path of another vehicle. All it takes is for one driver to have a momentary lapse of concentration, and an accident occurs. Driver assistance systems can help here, by correcting drivers' mistakes and giving them support in situations that can overtax their reactions and skills. Driver assistance systems such as Pre-Crash have had a positive impact on vehicle safety. To develop driver assistance systems, DENSO uses a tool chain in which several dSPACE tools play an important role:

- CalDesk (universal measurement and calibration software)
- dSPACE calibration and bypassing service (additional service code in the ECU that manages communication between the ECU and the dSPACE equipment)
- RTI Bypass Blockset (dialog-based configuration of bypass applications, assignment of variable names to ECU addresses)
- MicroAutoBox (prototyping system for calculating complex bypass functions in real time)
- DCI-GSI1 (Generic Serial Interface for ECU access via various on-chip debug interfaces)

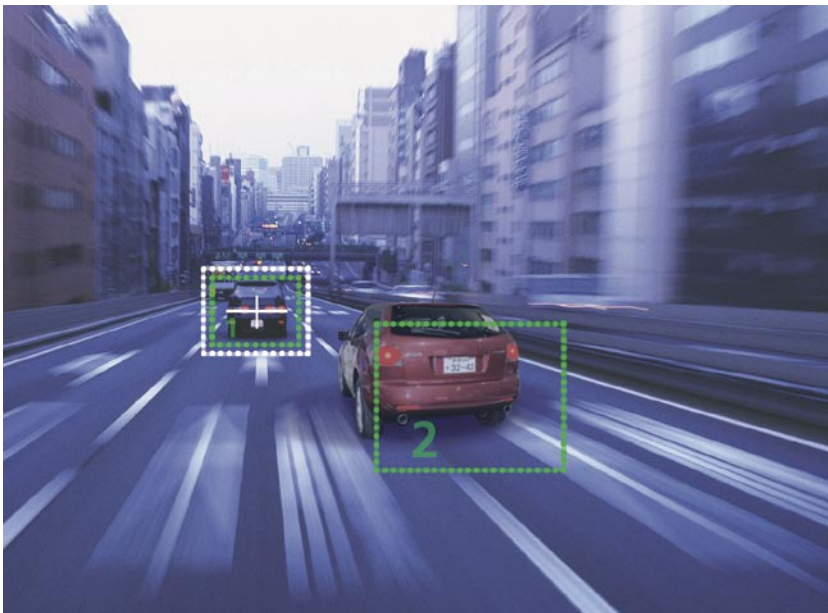

▲ The traffic as seen by the camera onboard the vehicle (reconstructed scene): The driver assistance system detects other road users (in this case there are two) and analyzes their direction and speed so that it can react in critical situations.

The Setup with dSPACE Equipment

A radar sensor and a video sensor are the vehicle's eyes. They observe the area in front, so that the driver assistance system can react to critical situations appropriately. An electronic control unit (the driver assistance ECU) evaluates the radar and video data to decide whether it needs to activate systems like the brake or the seatbelt tensioner.

Calibration, measurement, and bypass access to the ECU runs via the microcontroller's NBD on-chip debug interface and the DCI-GSI1, which is capable of handling all three scenarios synchronously and in parallel without compromising bypass latencies.

CalDesk is used for several different purposes: first, for ECU calibration, and to capture large amounts of data from certain arrays of several kBytes in the ECU RAM; second, to control and monitor parameters of new bypass functions on the MicroAutoBox;

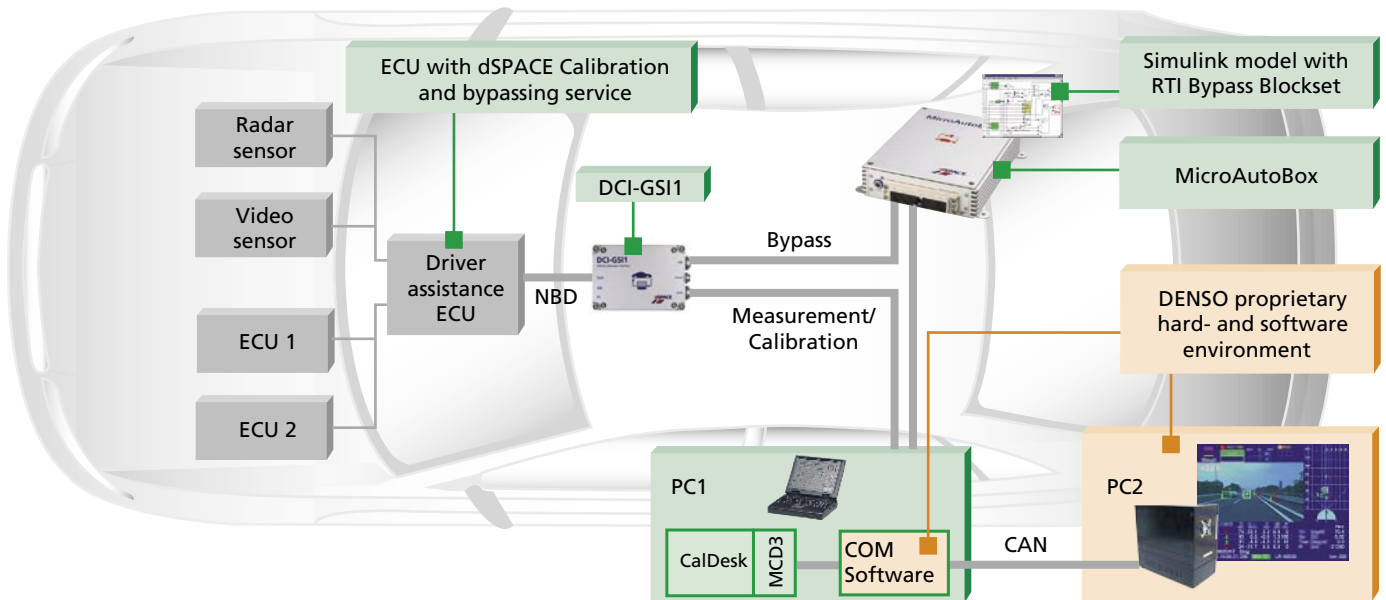

and third, to feed ECU-internal data (via ASAM-MCD 3) to DENSO's dedicated software environment on a second PC (PC2). DENSO has implemented its own Windows® COM application, which is executed on the first PC (PC1) in order to transmit relevant data to PC2 via the CAN bus. CAN was used as the communication interface between the two PCs, since the DENSO software environment already supported CAN. The dSPACE Calibration and Bypassing Service is

system in a defined and reproducible way, and optimize it. A typical case involves a dummy pedestrian and two vehicles, one of which is equipped with the driver assistance system. The dummy pedestrian can be moved by a motor to imitate a pedestrian suddenly running onto the road from behind a car. The radar sensor detected the pedestrian so fast that the driver assistance system activated the brake and the seatbelt tensioner before the collision.

▲ Schematic of the setup for developing the driver assistance system.

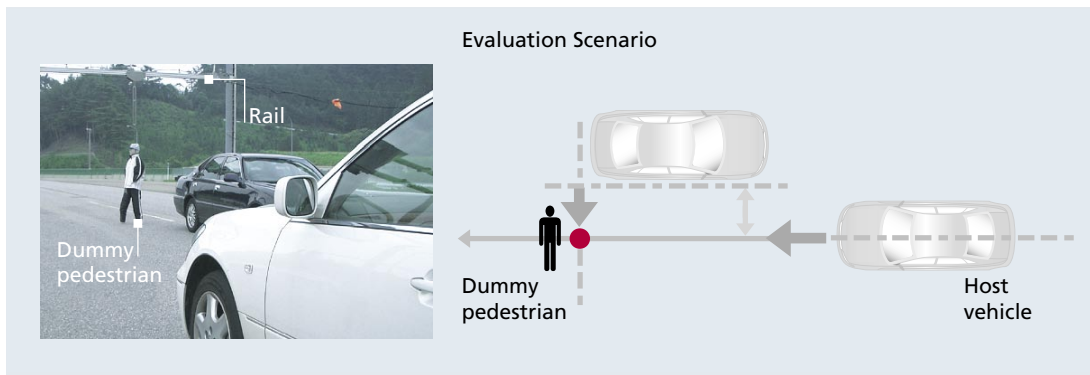

◀ The proving ground with several cars and a dummy pedestrian reproduces typical traffic situations.

integrated in the driver assistance ECU. The service provides access to the ECU application, and communication between the ECU and the other dSPACE equipment. In combination with the Generic Serial Interface (GSI), the service feeds CalDesk with ECU-internal data, for example, from the radar and video sensors in the vehicle.

System Evaluation

To test the driver assistance system, DENSO constructed a proving ground for reconstructing typical traffic situations. Thus, DENSO can check the reactions of the

Results and Future Steps

DENSO will complete the integration of environments for two actual-vehicle-based development processes, rapid control prototyping and measurement/calibration. The fact that dSPACE products are ASAM-compliant greatly facilitates linkage between development tools, so from now on, DENSO plans to extend the coordinated development process to cover other development tasks.

Takao Nishimura, Masao Ohoka
DENSO CORPORATION
Japan

Fiat Auto – Testing Diagnostics Capability

➤ **Virtual Vehicle
built on ASM
Vehicle Dynamics
Simulation Package**

➤ **Simulation results
matched measured
vehicle dynamics**

➤ **Being used to test
ESP diagnostics**

▼ *Diagnostic capability testing with the ASM Vehicle Dynamics Simulation Package was performed for the ESP controller of the Fiat Ducato.*

As complexity continues to explode, vehicle diagnostics are vital. About 30-40% of memory in modern automotive electronic control units (ECUs) is dedicated to diagnostics. After successful evaluation of the Vehicle Dynamics Simulation Package, which is part of the Automotive Simulation Models (ASM), dSPACE's real-time models for hardware-in-the-loop simulation, Fiat Auto decided to use it in a turn-key solution with dSPACE Simulator to test the diagnostic capability of electronic stability programs (ESP).

Diagnostics means that the ECU is capable of detecting faults in the systems it is connected to. These are first of all the communication buses – in our case CAN – and also the wiring, for instance, to the wheel speed sensors. Safety-critical systems like electronic stability programs (ESP) are subject to fail-safe requirements aimed at preventing unwanted operations during critical driving situations. Detected faults can have several consequences:

- Fail-safe strategies are launched in the ECU
- A diagnostic trouble code (DTC) with a time stamp is written to the ECU's error memory
- A warning light tells the driver there is a problem



Diagnostic features are specified by Fiat Auto for vehicle-related functions, and by the ECU supplier for purely ECU-related functions in the ECU.

Frontloading with HIL

The aim is to implement diagnostic functions early on, in parallel to control function development. Vehicle prototypes are usually rare at that stage, and testing diagnostic capabilities on the road would be very difficult. Moreover, it is quite easy to create conditions such as road features (friction, bumps, etc.) or extreme driving maneuvers in the laboratory, so a frequent way of speeding up the development process is to use virtual vehicles in virtual environments in hardware-in-the-loop (HIL) simulators. Another reason why HIL tests are so useful is test reproducibility, which makes it easy to verify whether problems were really solved.

Fail-Safe Analyses

Fail-safe analyses have to be performed during certain vehicle maneuvers to determine the behavior of a safety-critical system in the event of failures. The key to testing diagnostic capability is the ESP system's reaction to CAN test messages. These are basically modified signals that would not be plausible in a certain context. Testing includes checking the plausibility and timing of messages, and electrical failures like wire breaks or short circuits can be simulated. Precise, real-time simulation of a vehicle's dynamic behavior is required to test all these things properly.

Highly Accurate Test System

In order to get reliable results regarding DTC correctness, we first evaluated the ASM Vehicle Dynamics Simulation Package from dSPACE to check if simulation results matched measured vehicle data.

We drove a prototype of the new Fiat Ducato on our test tracks in Turin and captured vehicle dynamics data. Then we created a virtual test scenario via the Maneuver Editor in ModelDesk, the graphical configuration and parameterization software for the vehicle model. Performing simulations with the properly parameterized vehicle model delivered results that matched the actual vehicle dynamics data very closely. The ASM Vehicle Dynamics Simulation Package is clearly of high quality and well parameterized by dSPACE, as it delivers very precise real-time simulation results.

Virtual Test Drives with ASM Vehicle Dynamics

To test the ECU against our requirements specification in early stages of the vehicle's development process, we used a dSPACE Simulator Mid-Size that ran the ASM Vehicle Dynamics Simulation Package. We performed virtual test drives with several maneuvers which we created to simulate driving situations requiring ESP activities, including different lateral and longitudinal accelerations at certain speeds. With the Stimulus Editor in dSPACE's ControlDesk, we created test sequences to insert CAN test messages into the ESP's CAN communication. The driving behavior was visualized with dSPACE's 3-D online animation tool, MotionDesk. If signals are not plausible to the ECU, DTCs are written to the ECU's fault memory together with a time stamp. Thus, DTC correctness can be verified relative to maneuver progress

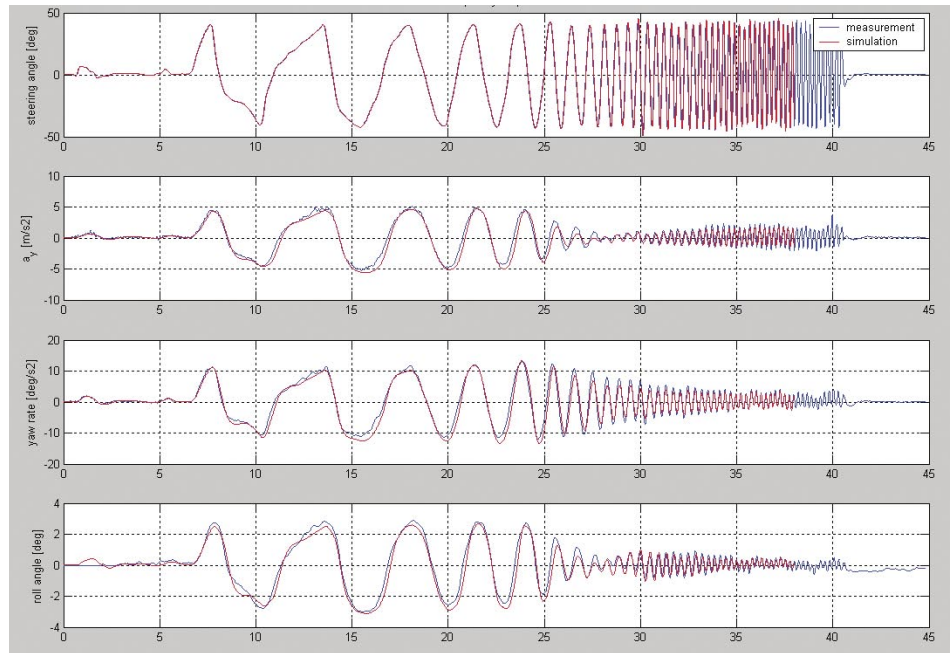

Achievements and Outlook

So far we successfully used the dSPACE Simulator and the ASM Vehicle Simulation Package to test the ESP systems of the Fiat Ducato. We are satisfied with the system and plan to use it for other ESP controllers as well. An extended test automation shall be implemented. The announced ModelDesk tool automation interface will therefore be very useful for us.

▲ Comparison of simulation results with measured vehicle dynamics data during a sinus steering maneuver. The test car was a fully loaded Fiat Ducato (weight 3.5 t).

"The simulation results of the ASM Vehicle Dynamics Simulation Package matched the measured vehicle dynamics very closely. We are convinced that the model is of high quality."
Luca Remolif

and CAN test messages. Since the same maneuvers and tests can be performed with high reproducibility, we can verify whether faults were solved and reliably validate the diagnostic capability of the ESP system. We have a test automation system based on Python installed, and integrated ControlDesk with DIAnalyzer, the diagnostic tool from Fiat Auto, as a link to the diagnostic bus.



Luca Remolif,
Stefano Manganiello,
E & D Department,
Fiat Auto S.p.A.,
Italy

▲ ControlDesk and DIAnalyzer exchange diagnostic data.

Braking at Full Speed

- **Developing the ETRAS® system for the Airbus A380**
- **Controller developed using a dSPACE prototyping system according to safety standard DO-178B Level A**
- **First fully electric thrust reverser in commercial aviation**

As a passenger on an airplane, if you watch the engines closely, you can observe the effect of thrust reversal as it occurs: As soon as the plane touches down, a vent opens in the engine cowl, and some of the air drawn in by the engine is ejected forward to decelerate the plane. To develop the ETRAS® system on the Airbus A380, Hispano-Suiza, a SAFRAN Group company, used a dSPACE prototyping system. ETRAS® is a fully electrical system with no hydraulic or pneumatic components – the first ever in passenger planes.

Why Reverse Thrust to Brake?

Thrust reversal in aircraft is an additional braking system that takes some of the load off the mechanical wheel brakes to shorten the braking distance. It is also helpful in rain, ice, and snow, when the wheel brakes lose some of their effectiveness. In the Airbus A380, thrust reversal is achieved by a system of flaps that open on the side of the engine when the plane lands, to deflect some of the air flow forward. The engine blades continue rotating in the same direction as during flight. At first sight, it might seem to make sense to simply change the direction of blade rotation – braking in the same way as a ship does at sea, so to speak – but this is actually no use in aircraft. It takes too long, and by the time the direction of rotation has changed, the aircraft has reached the end of the runway.

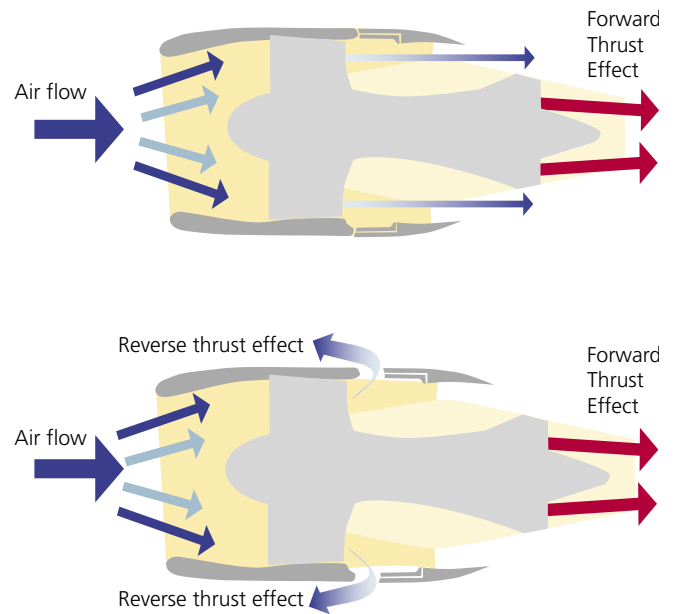

▲ In thrust reversal (lower picture), braking is performed by a system of flaps that deflects some of the air drawn in by the engine and gives it forward thrust.

▼ The thrust reverser is one of the engine nacelle modules (outer diameter around 4 m). The control algorithms for the thrust reverser were developed via a dSPACE prototyping system.

The ETRAS® System – Fully Electric

The dSPACE prototyping system helped us to reduce the risks involved in the complete plane nacelle system for ETRAS® (Electrical Thrust Reverser Actuation

System) by validating and optimizing the control algorithms (functional and safety levels). This way, we saved

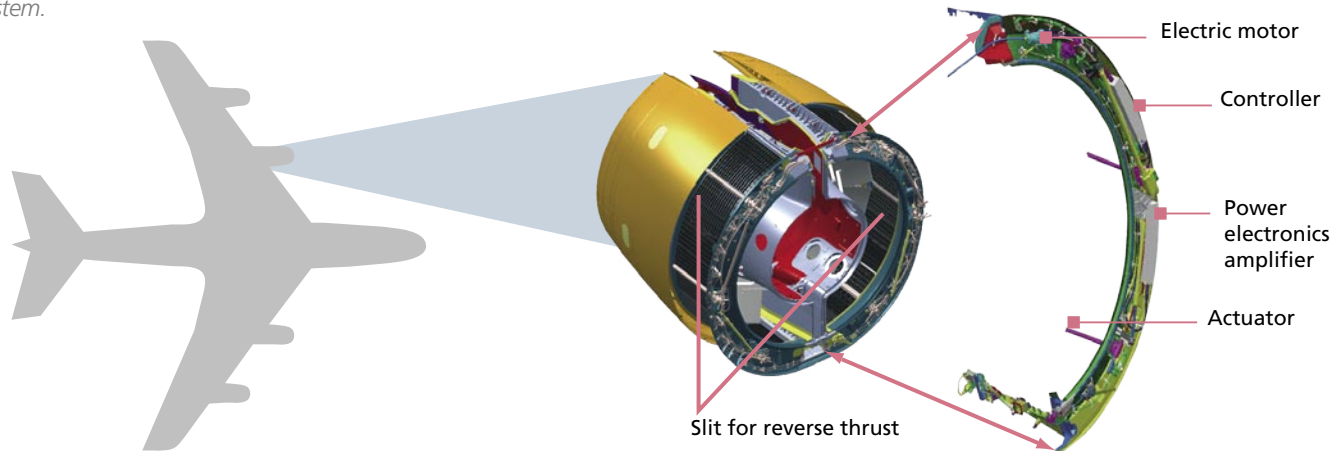

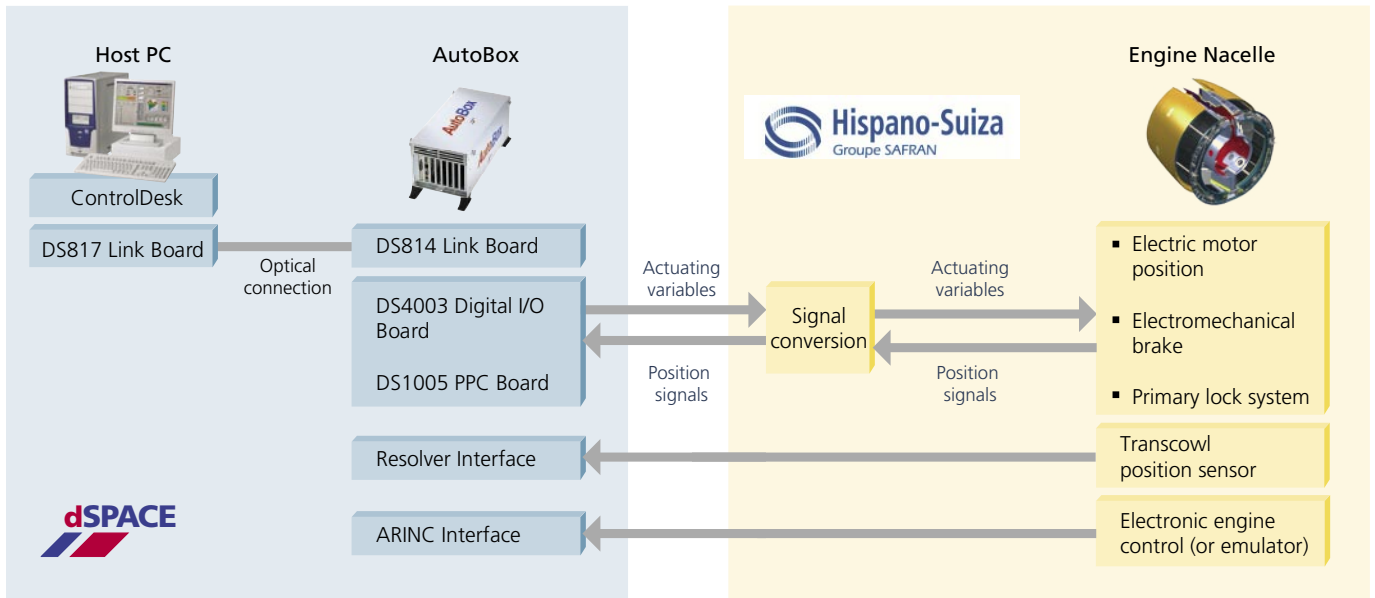

a lot of time and were able to begin the final embedded software development at an early phase, and validate it according to the aviation standard DO-178B Level A.

The ETRAS® system, developed in partnership with Honeywell, is fitted on the nacelles, which were designed and produced by fellow SAFRAN Group company Aircelle for both the engines offered on Airbus A380: the Rolls Royce Trent 902 and the Engine Alliance GP7200. The thrust reverser is a safety-critical system and has to meet some important requirements:

- Thrust reversal must deploy only on the ground.
- Thrust reversal must deploy immediately when the plane touches down, at pilot request.
- The strength and direction of thrust reversal must be appropriate for the engine and the aircraft type.
- The effect of thrust reversal on the aircraft must be symmetrical, to prevent undesired cornering.

Flexible Development Environment

The dSPACE prototyping system, consisting essentially of the DS1005, I/O, interface boards, and the ControlDesk experiment software, gave us an-easy-to-use environment for developing the algorithms for thrust reversal control in the Airbus A380. The control algorithms were designed using MATLAB®/Simulink® and executed on the prototyping hardware using dSPACE's experiment interface, ControlDesk. One of the tasks of the dSPACE prototyping system was to capture sensor signals (incl. the speed and positions of various posi-

tioning motors and threaded spindles, and air flow) via I/O interfaces and a resolver interface dedicated to electric motors. This data was then used to calculate the actuating variables for the strength of thrust reversal, which controlled the actuators.

On the Way to a "More Electric Aircraft"

The ETRAS® system is the first ever mounted in a commercial plane to manage entirely without hydraulic or pneumatic components. More electrics and less hydraulics

"Because of its good flexibility and reactivity, the dSPACE prototyping system performed very well in the development of the first fully electric thrust reverser for commercial aircraft (ETRAS®)."

Nicolas Huttin

means less weight and therefore less fuel consumption. Aircraft manufacturers throughout the world will therefore continue this trend towards a "more electric aircraft" in other aircraft or engine systems in the future. With our tool landscape, based on a dSPACE prototyping system, we are optimally equipped to meet this challenge. Thanks to its modularity and flexible configurability, the system will allow us to adjust to future tasks with a minimum of effort.

*Nicolas Gazel, Nicolas Huttin, Régis Meuret, Antonio Prata
Hispano-Suiza
France*

▲ Schematic of the development environment with dSPACE equipment.

EDGAR – A Self-Balancing Scooter

University of Adelaide develops EDGAR

Rapid control prototyping of self-balancing scooter

Real-time control project for final year students

Mechatronic Engineering students at the University of Adelaide often undertake real-time control projects as part of their final year thesis. One of these projects, EDGAR (Electro-Drive Grav-Aware Ride), covers the design and testing of a two-wheeled, self-balancing vehicle capable of carrying a human. A dSPACE DS1104 R&D Controller Board was used to rapid-prototype the controller prior to embedding the controller on a low-cost microcontroller target.

As part of their final year, Mechatronic Engineering students at the University of Adelaide are required to undertake 300-500 hours on a design project involving systems engineering and integration. Many of these projects involve real-time control, and the dSPACE DS1104 R&D Controller Board is the preferred development tool. The aim of the EDGAR project

Hardware Operation

EDGAR was designed to be robust and easy to use whilst not compromising on strength and weight. The design included special attention to aesthetics of the vehicle and the ergonomics of the rider-vehicle interface. The process EDGAR goes through to self-balance is similar to how a human balances. The human brain recognizes the force due to gravity on the vestibular system, from which it is able to detect the orientation. It then sends impulses to the muscles in the limbs to maintain balance. Similarly EDGAR's controller receives information from an inertial sensor and then sends appropriate commands to the drive system to provide balance in pitch.

The Control System

An inertial measurement unit is used to measure the angle and angular rate of the pitch, roll and yaw of the device. These signals are then communicated to the DS1104 board via a serial RS232 link.

The drive system consists of two coaxial geared motors driven by a dual channel motor controller often used in hobby robotic applications. Two capacitive sensors located in the footplate detect the presence of a rider. We use this information to activate or deactivate the stabilizing controller. LEDs in the handle bars indicate a number of different operational states.

Steering (yaw) control is open-loop differential control of the torques to the left and right motors. The desired steering angle can be chosen using a potentiometer-instrumented grip in the handlebars.



Final-year student Simon McMahon is taking EDGAR for a test drive through the University of Adelaide campus.

was to design and build a self-balancing scooter that functioned in a similar manner to the Segway Human Transporter (HT), using a control law to stabilize the scooter by feeding back angular position signals from a gyroscopic unit into signals for the drive system. The design is loosely based around the Segway HT, which is the first commercially available self-balancing vehicle. The design is based on the successes and failures of other attempts at replicating a Segway HT.

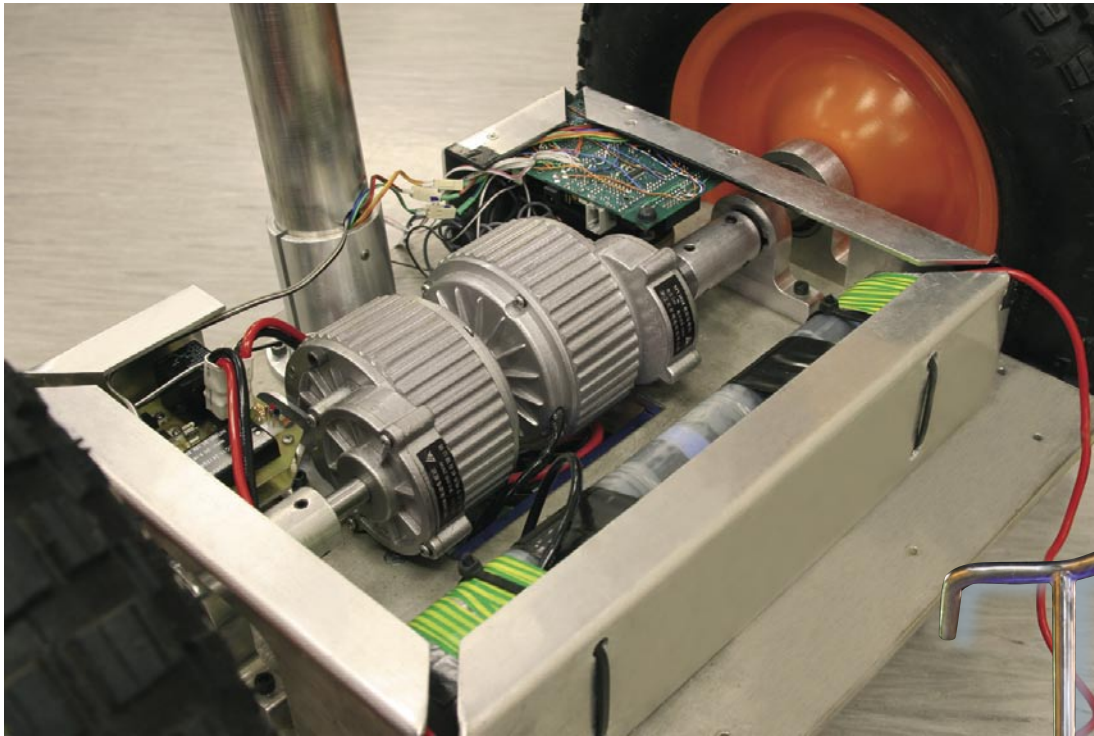

◀ EDGAR's insides.
From front to back:
Battery pack, two
coupled motors and
gearboxes, power
distribution board,
microcontroller and
inertial measurement
unit.



Control Development

Prior to developing the real-time controller, we studied the dynamics of EDGAR on a Simulink® model. This allowed the development of the control laws in the safety of a virtual environment. A virtual reality model was added to visualize the behavior of EDGAR, thus verifying appropriate performance. Initial control development of the physical EDGAR was undertaken using Simulink with a DS1104 board and

"The dSPACE platform allowed the students to build extremely advanced control laws very rapidly, focusing on the control issues, rather than being distracted with lower-level concerns such as microcontroller programming or electronics."

Dr. Ben Cazzolato

the experiment environment ControlDesk. All signals from the DS1104 to the electronics on EDGAR were delivered via a multi-core cable. The DS1104 provided the ADC, DAC, PWM, serial and digital ports necessary for the safe and functional operation of EDGAR. We tested numerous stabilizing controllers including significant logic control to ensure safety. Once the details on the controller were finalized, it was cross-compiled for a Freescale MC9S12 microcontroller using a Simulink embedded target devel-

oped at the University of Adelaide. Only minor changes to the initial controller design were necessary to achieve a fully functioning prototype.

Outlook

The design and development of EDGAR provided the students with an interesting and enjoyable platform to learn real-time control. A fully functional device was built and tested in a single academic year. Having validated the design approach, a revised design is being developed this year by five new students, incorporating larger motors and more powerful motor controllers.

*Dr. Ben Cazzolato
Senior Lecturer in Control and Signal Processing
University of Adelaide
Australia*

Porsche – Virtual Manual Transmission

- **Shift force simulator for that authentic gear-shift feel**
- **Porsche relies on dSPACE real-time hardware**
- **Force feedback for realistic tests**

▼ *The shift force simulator closes the gap between virtual simulation and the actual drivetrain.*

The feel of a manual transmission is a brand-specific feature, and an important factor in customer test drives. Development of a specific gear-shift feel begins right back at the definition stage, when real prototype parts are not yet available. And virtual simulations cannot provide feel. Porsche closed the gap between virtual simulation and the actual drivetrain by developing a shift force simulator. At its core is powerful dSPACE real-time hardware that uses a Porsche simulation model to control the simulator actuators so as to provide a realistic gear-shift feel.

Brand-Specific Gear-Shift Feel

The gear stick is one of the controls in a vehicle that still gives the driver direct contact with the drive mechanism.

The basic aim of development work is to ensure good shifting quality in technical terms, but another is to provide a brand-specific gear-shift feel with a high recognition factor, to differentiate the vehicle from the competition in the same way as the engine sound does. Both static and dynamic effects are at work

on the gear-shift feel.

Shift Simulation and Shift Force Simulator

At various stages of development, simulation tools make it possible to determine what the shifting quality will be, if there will be any malfunctions, and whether the specifications are fulfilled, without having any real prototype parts available. However, up to now there were some factors that could not be evaluated in virtual simulation, such as direct gear-to-gear shifting, the gear stick guidance through the gates, and the engagement motion. But it is these very features that will later determine how a potential customer judges the subjective feel of a gear during a test drive. To give developers a flexible means of evaluation at an early stage, the idea of the shift force simulator was born. When effects have been determined in theory, the shift force simulator makes them “feelable”, so they can be evaluated subjectively.

Force Feedback Provides Answers

The shift force simulator is a real-time system with force feedback like that used in joysticks for computer games and also in flight simulators. Two electric drives coupled to the shift lever provide the force feedback. The core of the simulator is dSPACE real-time hardware and a Porsche simulation model of a virtual transmission modeled in MATLAB®/Simulink®. The hardware is a DS1104 R&D Controller Board, which calculates the complex Porsche model in real-time, and also serves the sensors and actuators. An even more powerful combination will be used in future, consisting of a DS1006 Processor Board and a DS2211 HIL I/O Board. Parameter variations can be run on the simulator, and their effects on gear-shifting can be felt immediately.



- Static effects are evaluated when the vehicle is stationary (with engine switched off) and the gear stick is operated slowly.
- Dynamic effects on the gear-shift feel are caused by the rotating gears and the oscillatable drivetrain, and also by the speed at which the gear stick is handled.

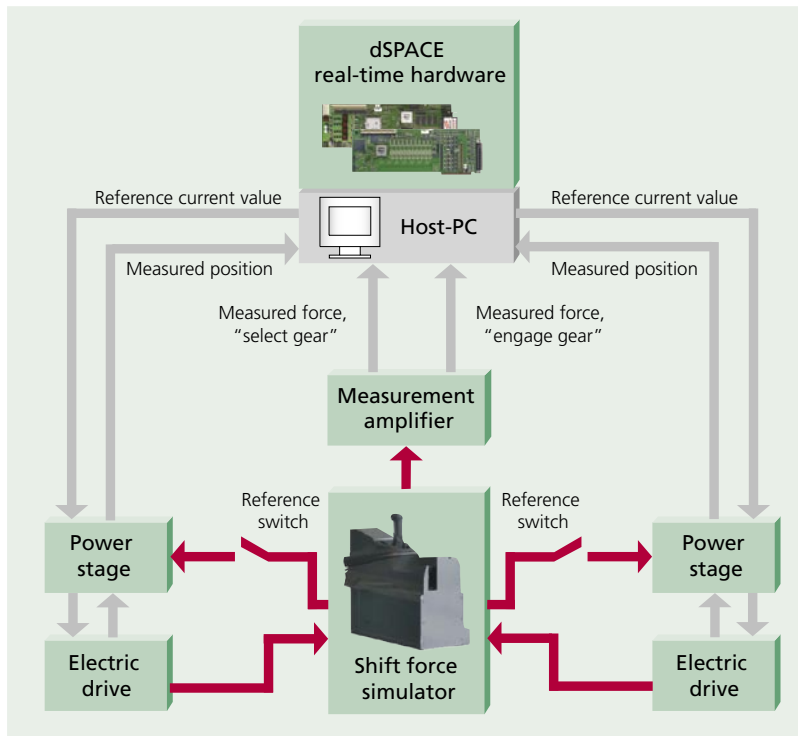

▲ *Shift force simulator: The electric drives are controlled by the dSPACE real-time hardware via power stages.*

To make conditions as realistic as possible, visualization and sound can also be integrated via an Ethernet interface from dSPACE and other hardware.

How the Shift Force Simulator Works

The inputs to the simulation model are the gear selection and engagement motions in relation to the force contact point. The gear stick position signals are provided by the power stages of the drives, which evaluate the signals of the high-resolution gear stick position measurement systems of the drives. The simulation model uses these position signals and the speeds derived from them to calculate the reaction forces which would affect the shift lever in reality. Pedal inputs (clutch, brake, and accelerator) are also read in and included in the simulation in addition to the operating variables at the gear lever. Thus, the simulator is an interactive system that reacts to user input. The forces calculated by the simulation model are the reference values for the force controller, which together with the measured force signals (actual forces) adjust the actuating values for the electric drives, in other words, the desired force. The force signals are measured at the shift lever and transmitted to the host PC and the dSPACE real-time hardware.

Summary and Outlook

The shift force simulator gives Porsche numerous application options in every stage of development, regardless of vehicle or transmission variant. Powerful dSPACE real-time hardware and the real-time simulation model (virtual transmission) form the core of the shift force simulator. The simulator is independent of real prototype parts and can be deployed flexibly in widely varying locations. Ergonomic aspects, such as the driver's position in relation to the gear stick, can be adjusted in many ways. Porsche uses the simulator not only for its own products, but also in custom development at Porsche Engineering.

*Frank Kurrle
Dr. Ing. h.c. F. Porsche AG in Weissach,
Frank Sayer
Porsche Engineering Services GmbH,
Germany*

Bypassing The Heart's Control

- dSPACE prototyping system helps medical engineers
- Intelligent blood sensor developed
- Bypass techniques mimic pacemaker

SterlingTech, a leader in providing innovative software solutions for medical device companies, helped a client receive a U.S. patent for an impedance sensor (a device to measure the flow of blood through the heart), after performing a series of experiments utilizing a dSPACE prototyping system, in combination with MATLAB® and Simulink® model-based control design software.

Bypassing Nature's Ultimate Controller

Bypassing is a viable technique in the area of rapid prototyping for optimizing control functions at the real plant, and one that has been traditionally used throughout the automotive and aerospace industries to validate new control algorithms for such mechanical applications as fuel injectors, auto pilot systems and anti-lock brakes. But the medical devices industry is taking rapid prototyping and bypassing to a whole new level. Medical technologists are utilizing rapid prototyping tools for research projects.

One of the companies working in this field is US-based SterlingTech, which specializes in software development for medical devices. SterlingTech recently completed a series of real-time prototyping experiments to help a

client receive a US patent (patent number: 5,999,854) for an impedance sensor – a device used to measure the flow of blood through the heart.

Intelligent Blood Flow Sensor

The sensor is intended to enhance cardiac rhythm management devices, including artificial pacemakers, by improving the measurement and control of blood flow through the heart, as well as preserving remaining battery life and detecting defective lead wires – problems that

need to be remedied as quickly as possible for cardiac patients. “The sensors that exist in today's pacemakers are not very good at speeding up the heart when a person is moving or exercising, or slowing it down when a person is at rest,” explained SterlingTech founder and president Dan Sterling. “We developed a sensor that can increase or decrease the flow of blood through the heart in real time.”

SterlingTech helped its client gain patent approval for its blood flow sensor by generating raw data to fully evaluate and support its validation.

Hearts Under Control

Using a dSPACE prototyping system, along with MATLAB/Simulink model-based design software, C and C++ for Windows/PC, and C and Assembly for the TI DSP (TMS320C4X), SterlingTech was able to build an experimental system to mimic the behavior of an actual pacemaker. The real-time system was successfully used to adjust and control the heart rates of live laboratory animals, both under anesthesia and awake on a treadmill. The system can be looked at as:

- “live laboratory animal” = plant
- “heart” = standard controller
- “dSPACE system” = bypass system to add features to the standard controller

“The system was able to sense the heart's demand for blood and pace the flow of blood through the heart in real time,” Sterling said. “The dSPACE equipment was actually running their hearts.”

The experimental system was used to run test algorithms, take real-time information from the impedance sensor and, ultimately, control the pacemaker.

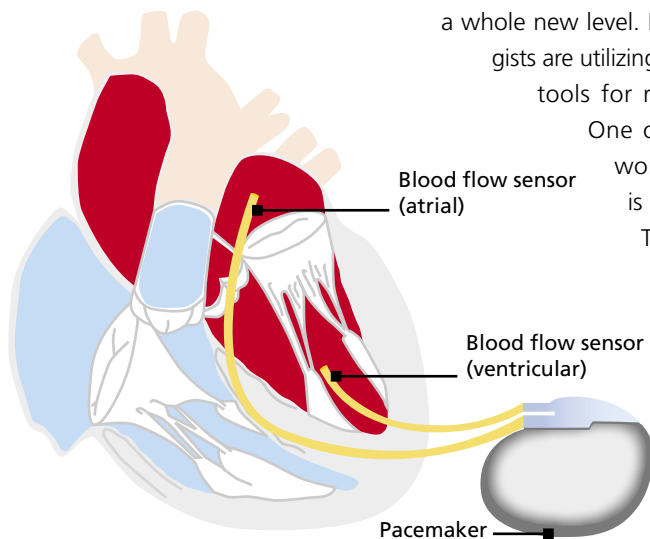

▲ The sensors are placed in the left atrium and left ventricle.

The SterlingTech team wrote software to set up and collect data from the sensor, and then implemented a pacemaker that could be configured as the client desired, in real-time, during the experiments. In addition, they created custom Simulink blocks with their new experimental algorithms programmed inside, in a way that could be configured at run time.

Since the experiments were performed on live animals, a high degree of reliability and control had to be maintained, while allowing easy and quick reconfiguration of the computer system.

Replay Program

The automated test capability of the dSPACE system made it possible for SterlingTech to establish a “replay” program. Raw data collected during animal experiments was rerun through the prototyping system with

“I would definitely recommend dSPACE products for use in performing clinical studies – especially those involving a lot of variability in parameters and rapid algorithm changes.”

Dan Sterling

different ideas implemented for the system configuration. This maximized the use of the data collected without having to repeat the experiments. “The systems

from dSPACE definitely met our needs,” Sterling said. “I would definitely recommend dSPACE products for use in performing clinical studies – especially those involving a lot of variability in parameters and rapid algorithm changes.”

As a result of the data that was produced from the experimental studies, a patent was issued to SterlingTech’s client for the impedance sensor. Use of the product on a commercial basis is pending.

Dan Sterling
President, SterlingTech

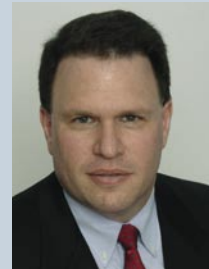

Dan has been serving as president of SterlingTech since the company was founded in 1988. He has long-term experience with safety-critical software development, including the design and testing of software for implantable and external medical devices, as well as monitoring equipment. His company offers software development and validation services.

www.SterlingTechSoftware.com
Tenafly, NJ, United States

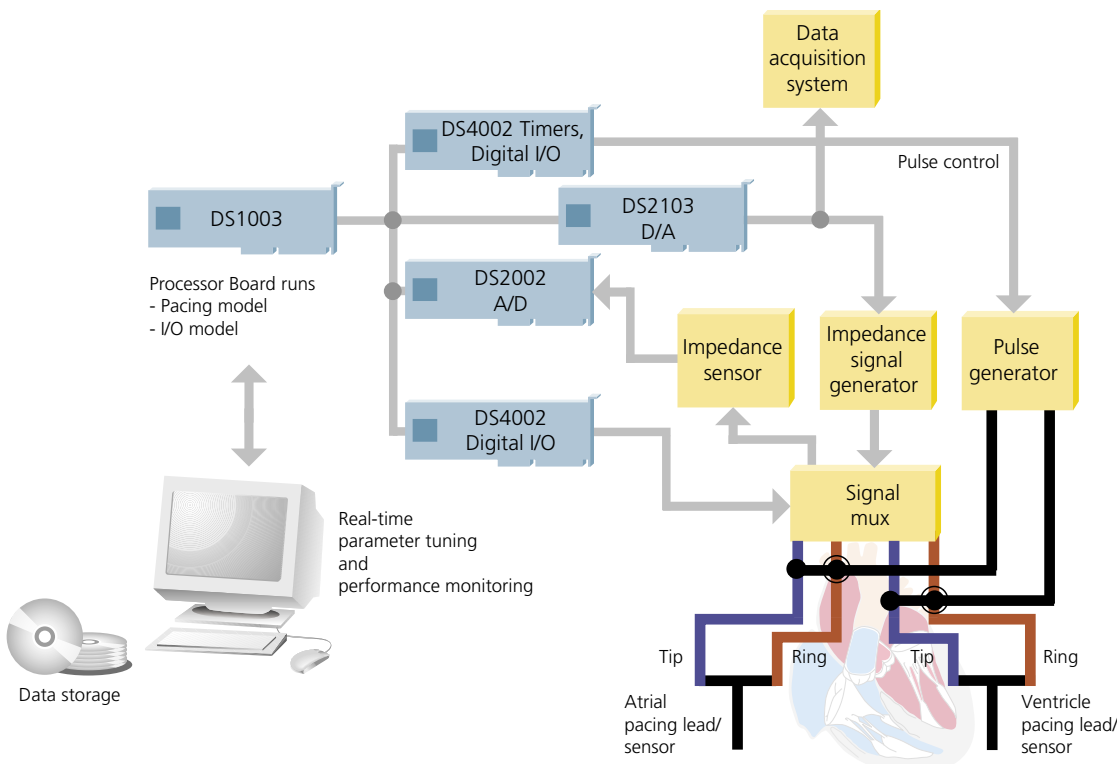

◀ Schematic of the setup. The lead into each of the heart chambers has two conductors at the end, one is at the tip and the other is a ring around the lead about an inch from the tip. Pacing is performed by creating an electrical current between the tip and ring. Impedance is measured by generating a signal on any of the two leads’ tips or rings and sensing on any combination of the others.

Golf GTI 53⁺¹ – The Driverless Car

- **VW Golf GTI drives itself**
- **Minimum lap times**
- **MicroAutoBox used for controlling**

The Golf GTI 53⁺¹ developed by VW can drive along a known road autonomously, with no driver. The aim is to test and verify control systems such as ABS and ESP in precisely reproducible test drives. A test track marked by traffic cones is measured by means of a laser scanner and a differential GPS (DPGS) navigation system, and the ideal line for achieving minimum lap times is computed. A MicroAutoBox from dSPACE controls the power steering, the accelerator pedal, and the brake booster automatically.

Electronic control units (ECUs) with electronic access to the engine, brakes, and chassis can intervene in the ongoing driving situation, for example, as assistants helping to avoid accidents. At VW, we converted a standard Golf GTI to enable it to drive round the defined track completely by itself, with minimum lap times along an ideal line. Our objective is to perform precisely reproducible test drives to test electronic control systems such as ABS, ESP, and EDTC (engine drag torque control). Incidentally, the test vehicle gets its name from Herbie, the self-driving Volkswagen Beetle who starred in several films and whose racing number is 53. The GTI 53⁺¹ is a worthy successor.

trip around the track, the GTI scans the area around it with the laser sensor as it crawls along from cone to cone. The DGPS navigation system measures its position with a precision of 2 cm. The MicroAutoBox runs the software for capturing the cone positions and controlling the autonomous drive. When the whole track has been captured, the GPS data is evaluated on a PC and the ideal line for minimum lap times is calculated.

"The MicroAutoBox lets us test changes to the models very fast."

Bernhard Müller-Bebler,
Volkswagen AG

▼ *The laser scanner uses a reflected laser beam to capture the positions of the traffic cones.*

"Herbie" Finds His Way

For the autonomous test drives, we added a DGPS navigation system and a laser scanner to the Golf GTI 53⁺¹, and also installed an active brake booster. On its first

Calculation software from the University of Hamburg determines the ideal line to drive along, using a special optimization procedure to minimize the steering effort and distance step by step. We use the results from this





◀ The GTI 53+1 drives round the cones on the test track loop completely autonomously.

to produce the specifications for maximum driving speed and longitudinal acceleration. Our software determines the optimum braking points and the maximum cornering speed, selects the most appropriate steering wheel rotations, and marks the full acceleration sections.

Full-Speed Cornering

After just 30 minutes computation time, all the data is ready for controlling the electromechanical power steering, the electronic accelerator pedal, and the brake booster without any intervention by a human driver. Once the vehicle has set off, it travels round the track completely automatically. The MicroAutoBox continues to compute all the necessary signals and control the bus system. Thanks to the numerous I/O interfaces, it was no problem to integrate the MicroAutoBox into the development environment. We find it an extremely helpful tool for testing our models, which we developed with MATLAB®/Simulink®. The parameters on the current driving situation and the precise vehicle position are supplied by the DGPS platform. However, the test vehicle is simply a test system, not a driving robot. It cannot alter the course of the computed track, so it cannot swerve to avoid any obstacles that appear, even if they are detected by the laser sensor.

Further Developments

Our basic aim is to collect object measurement data, by means of aids such as the MicroAutoBox, as a basis for further evaluation and greater transparency. To achieve this, we will enhance the precision of traffic cone detection and also improve the electromechanical steering. Electronic linkages will continue to gain ground over mechanical

ones in the future. Our production vehicles have had electronic accelerator pedals for a long time now – to put it more precisely, since the introduction of turbocharged direct injection (TDI) – so they are connected to the vehicle electronics via an electrical cable. Our GTI 53+1 is a major contribution to further development of this technology.

*Carsten Spichalsky
Group Research
Head of Vehicle Dynamics
Volkswagen AG
Germany*



▲ The MicroAutoBox was installed in the trunk of the test vehicle.

Glossary

Engine drag torque control –

If wheel slip occurs due to abrupt throttling, the throttle valve is opened, thereby increasing engine speed (in conjunction with ABS and ASR).

DGPS navigation (differential global positioning system) –

A method of enhancing the precision of GPS navigation by transmitting correction data.

The Robot's Net

➤ **Cable-based robot inspired by spiders' webs**

➤ **Positioning at ten times Earth's acceleration**

➤ **dSPACE prototyping system provides powerful control**

Engineers and mathematicians in the Mechatronics department at the University of Duisburg-Essen in Germany have for some years now been working on a new, innovative type of robot. With inspiration from spiders' webs and the enormous load-bearing capacity of modern high-tech cables, future robots will use cables to get things moving in numerous application areas. A dSPACE system based on a DS1005 PPC Board provides powerful, reliable control.

In many industrial applications, a robot's payload is all but negligible in comparison with its own mass. This means that when the payload is transported, by far the greatest proportion of energy is needed for accelerating the robot itself. High energy consumption and low acceleration power are the result.

Ten Times the Earth's Gravitational Acceleration

Our team of researchers at the University of Duisburg-Essen is working on a new kind of robot that will avoid this disadvantage. The idea is to use cables to move and position a payload such as a platform with a gripper. The lengths of the cables determine the position of the platform. To change each cable length quickly, the cables are wound on winches that are each driven directly. Because the cable winches are mounted in fixed positions on a supporting framework, only the inertia of the platform with payload and the moment of inertia of the cable winches have to be overcome. The cables themselves have a negligibly low mass, and being made of modern, high-tech fiber, also enormous tensile strength. The prototype, SEGESTA, reveals the potential of cable-based parallel robots, as they are called. SEGESTA reaches accelerations up to ten times that of the Earth, and speeds of up to 10 m/s. Thus, even as only a prototype, the system already exceeds that of most off-the-shelf industrial robots.

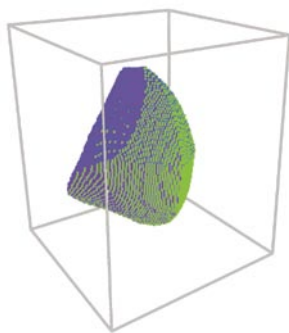

▲ *SEGESTA's usable workspace as determined by simulation.*

Motor Winches Take the Load

One interesting point is that because the platform has six degrees of freedom (translation, rotation), it has to be held by at least seven cables to fix its position in space. This is because cables can only pull, but not push. The parallel structure produces relatively complex workspaces for the cable-based systems being studied. The forces that arise can be distributed across



▲ *Working on the prototype: The mechanical structure is simple, the control system complex.*

any required number of motor winches, so the machine can transport very heavy loads, like the ones handled by cranes, at comparatively high accelerations and speeds. If heavier payloads have to be carried, extra winches can simply be added to increase safety and the maximum bearing capacity. The conceivable magnitudes can vary from very large, heavy-load robots right down to the micro range.

Reliable Control System with dSPACE

We have very tough requirements regarding the control system, since the achievable speeds necessitate a high controller frequency of at least 1 kHz. Moreover, a powerful processor is needed to calculate the cable lengths and cable forces. Thus, we were looking for a control system with industrial reliability for our

test setup, and we chose a dSPACE system. We put together a powerful control system based on a DS1005 PPC Board supplemented by numerous I/O boards (DS2103 Multi-Channel D/A Board, DS3001 Incremental Encoder Interface Boards, DS4302 CAN Interface Board), which can also be conveniently programmed via MATLAB®/Simulink®. The system is also ideal for giving students an insight into a modern control system.

The control system has the following structure:

- The system interpolates the position and speed along the desired trajectory to provide the reference variables.
- The inverse kinematics computes the cable lengths and speeds to fit the desired position and speed.
- The actual lengths of the cables (and the actual speed, using numeric differentiation) are determined via the I/O of the dSPACE system.
- A PD controller calculates the reference currents and sends them to the prototype's digital motor controller.

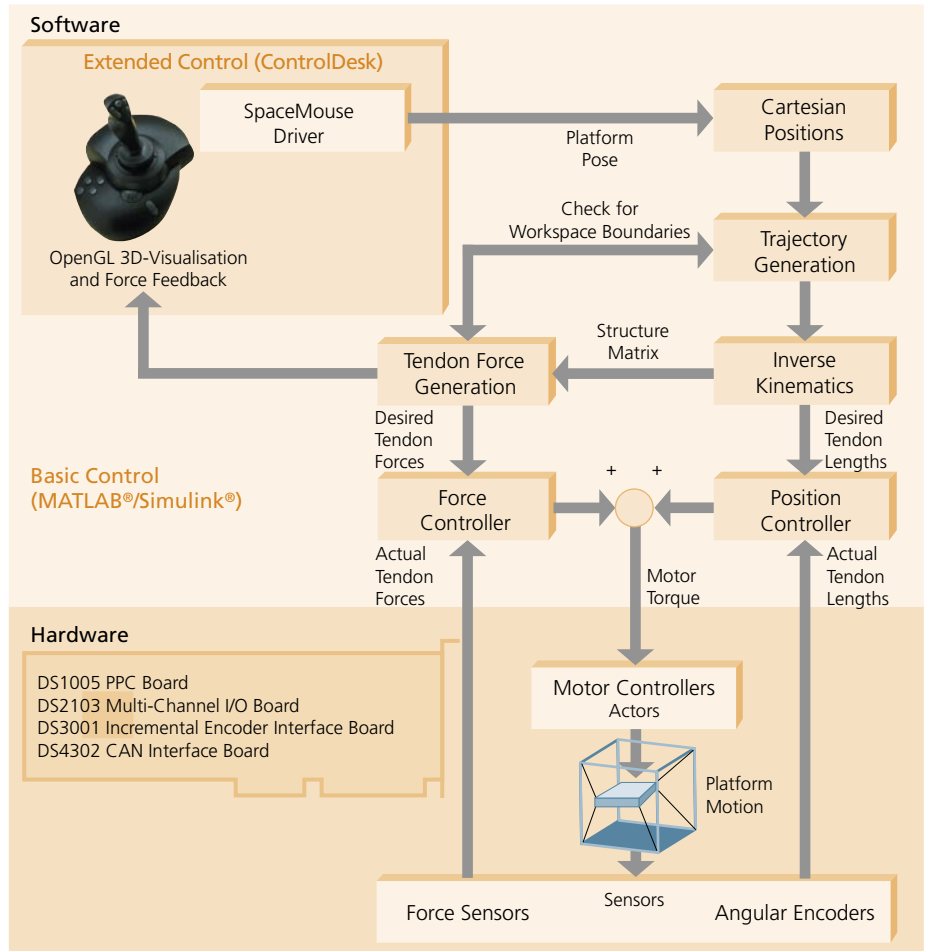

In manual mode, the test setup benefits greatly from the flexible integration of Windows® input devices via ControlDesk's experiment environment.

The Silken Thread in Practice

The possible application areas of cable-based parallel robots are many and varied. Any kind of application requiring a large workspace is conceivable, for example, transportation in large factories or storehouses, and also applications that would benefit from high speeds, such as industrial handling and pick-and-place. The system could also conceivably run in direct contact with people, for example, as a fairground ride, or giving valuable support in the sphere of medical rehabilitation technology. In the latter field particularly, we are hoping to cooperate with other German and European partners to develop an orthopedic aid that uses the "silken thread" to help patients practice walking movements, for example, after accidents or operations. The cables would be attached to a corset worn by the patient, either with a small degree of slack to provide extra safety, or pulled taut to hold the patient's entire weight. The idea is that because the mechanism is so

inconspicuous, the patient would not have the feeling of being hooked up to a machine. The cables are simply there to give support.

▲ *The control schema for force and positioning control on the SEGESTA test bench.*

*Tobias Bruckmann
Chair of Mechatronics,
under Prof. Dr.-Ing. Dieter Schramm
(previously Prof. Dr.-Ing. Manfred Hiller)
University of Duisburg-Essen
Germany*

Glossary

Cartesian positions – Positions expressed in terms of height, width, and depth.

Inverse kinematics – Compute the rope lengths from the position of the platform.

Parallel systems – A group of robots.

Workspace – The area in which the robot can move (translation in all 3 spatial directions, rotation around all three axes).

Ford Fiesta with Micro Hybrid Drive

- **Ford Fiesta with micro hybrid drive at Ford Research Center Aachen**
- **Optimized energy management and stop-start function**
- **MicroAutoBox, ControlDesk, CalDesk, and TargetLink used**

The Ford Research Center Aachen, Germany, is intensively engaged in developing operating strategies and energy management concepts for hybrid drive structures. A Ford Fiesta is being used as the experimental vehicle for testing and optimizing a micro hybrid drive, focusing on control strategies for hybrid-drive-specific functions such as stop/start and regenerative braking. Ford is using a MicroAutoBox, the ControlDesk test software, and the CalDesk calibration software for this task.

Developing vehicles with a variety of hybrid drive concepts is currently a major focus at automobile manufacturers. One reason is customers' demands for systems with more power, and for greater safety and comfort. Legislation on exhaust reduction (Euro 5 emission standard) and the industry's voluntary commitment to reducing CO₂ emissions (ACEA agreement) also necessitate new propulsion concepts.

The bandwidth of hybrid drives ranges from what are called micro hybrid drives to mild, medium, and even full hybrid concepts:

- Micro hybrid drives are defined as a combination of stop/start functions, regenerative braking in which the battery is recharged by the generator in deceleration phases, and sometimes also restricted electric propulsion support during acceleration.
- Full hybrid drives have at least one powerful electric motor and a traction battery which allows completely electrical propulsion, plus the functions listed above. Regenerative braking and propulsion support during acceleration are performed at a suitably high performance level.
- Mild and medium hybrid structures are between micro and full hybrid in functionality and features.

▼ *The Ford Fiesta demonstration vehicle with micro hybrid drive.*



Micro hybrid drives are considerably less expensive than full hybrid drives. The ratio of additional costs to achievable fuel consumption reduction means they can compete with other vehicle-related CO₂ reduction measures. Micro hybrid concepts are therefore an interesting alternative for the mass market. As well as the stop/start and regenerative braking functions, they also have a function known as stall recovery. This restarts the engine automatically if it stalls. The

core component representing this function is a belt-driven, integrated starter-generator (B-ISG), which replaces the conventional generator in the vehicle.

Stop/Start Function

The stop/start function switches the engine off when it is idle. This avoids CO₂ and other emissions, and also saves fuel, for example, while the vehicle is waiting at traffic lights. The engine is then automatically restarted by the B-ISG machine. It is not possible, or desirable, to switch off the engine in every case, so the state of the vehicle and its subsystems is monitored and analyzed. This is done by a MicroAutoBox, which receives its data from various sensors distributed throughout the vehicle, and from the CAN bus networks in the vehicle. The MicroAutoBox is also the bus master in a LIN bus installation, serving an intelligent battery

“CalDesk has considerable advantages in terms of simple handling and fast switching of different parameter sets.”

Holger Jung

monitoring system. The operating strategy that was implemented prevents the combustion engine from being switched off, for example, during the warm-up phase of engine and catalytic converter, or if the battery is low.

Regenerative Braking

Another potential fuel saving with the micro hybrid drive is when the vehicle decelerates. During deceleration, part of the vehicle’s kinetic energy is converted into electrical energy by means of the B-ISG machine. The MicroAutoBox controls the B-ISG power electronics via a CAN bus. The generated energy is

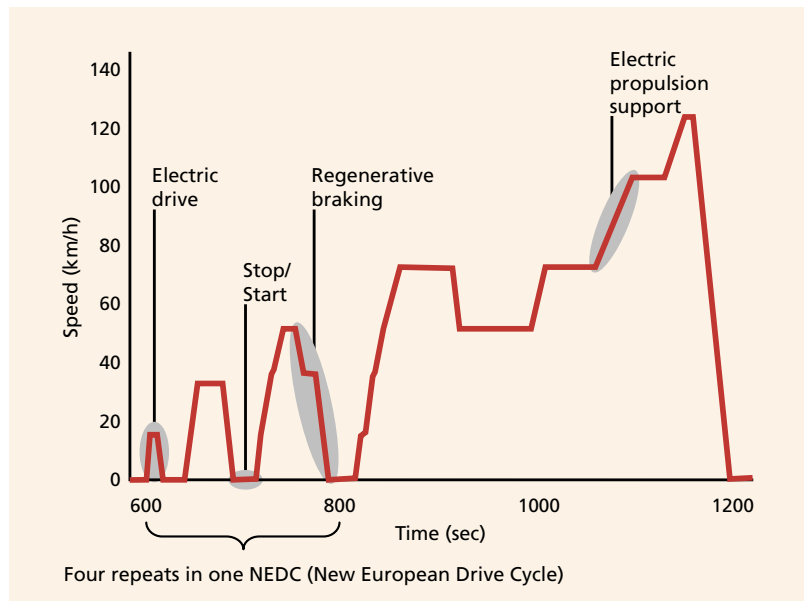

stored in the battery and made available whenever generating electrical energy is fuel-intensive or even impossible, for example, during acceleration phases or engine shutdown.

When a vehicle is used mainly in city traffic, these functions cut fuel consumption by up to 15%.

▲ *The New European Drive Cycle (NEDC) shows the phases in which fuel can be saved by means of hybrid components.*

Development with the dSPACE Tool Chain

The stop-start strategy and the control strategy for regenerative braking in the Fiesta were developed from the beginning with MATLAB®/Simulink® and implemented on the MicroAutoBox via dSPACE’s Real-Time Interface (RTI) and the LIN and CAN Block-sets. With a view to later portation to a potential target platform, only TargetLink-compatible blocks were used in the actual strategy. This ensures that when development work using TargetLink is completed, production-ready ECU code can be generated

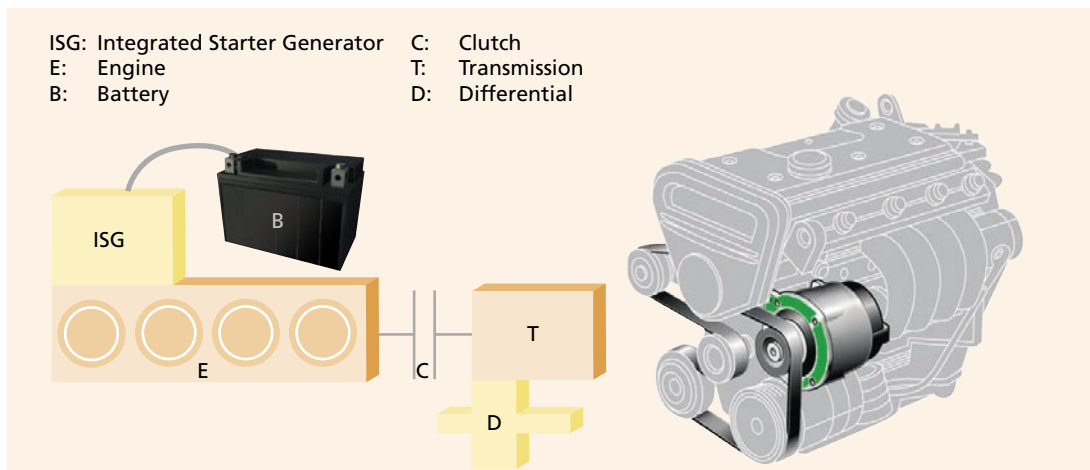

◀ *Schematic of the engine with starter-generator (B-ISG).*

dSPACE Product	Application Area
Real-Time Interface, LIN/CAN-Blockset	Implementing the control strategy on MicroAutoBox
MicroAutoBox	Developing the control strategy by rapid control prototyping
ControlDesk	Testing and managing control strategies
CalDesk	Managing parameter sets, switching between calibrated parameter sets, Testing and managing the control strategy
TargetLink	Generating production code for the ECU

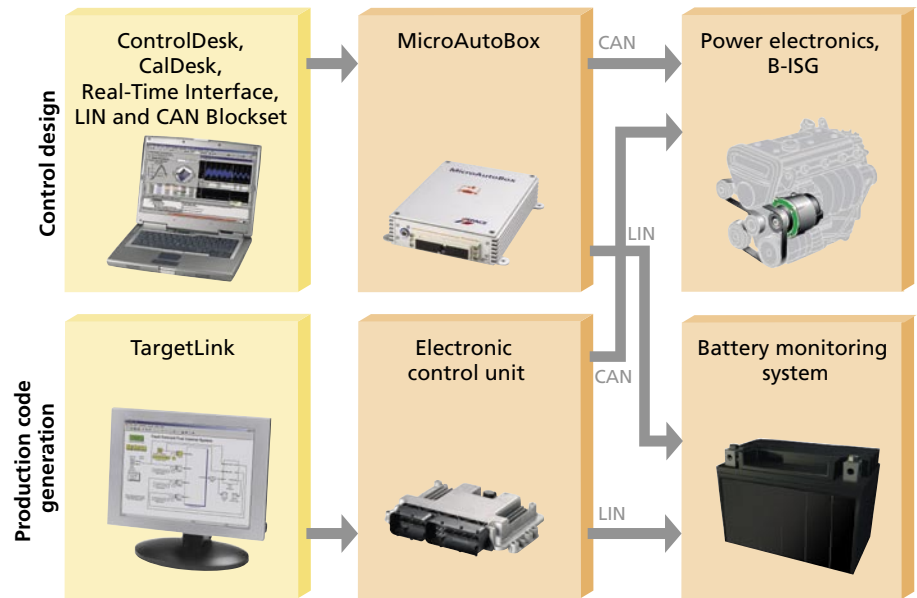

▲ Schematic of the development process with the products used and their application areas.

from the model. At the start, ControlDesk was used to calibrate the strategy. Later on, the team switched to CalDesk. To do so, first some of the blocks in the independent TargetLink library had to be modified so that parameters with useful names (variable names from the data dictionary) were available in CalDesk. As we see it, using CalDesk as early as the rapid control prototyping phase with the MicroAutoBox has considerable advantages in terms of easy handling and fast switching of different calibrated parameter sets. Moreover, recorded measurements can be directly analyzed in the original displays, which saves

time. Last but not least, CalDesk allows seamless transition to tests on the target processor. Both the tests using MicroAutoBox and the tests on the target processor are performed in the vehicle.

*Edo Aneke, Urs Christen, Holger Jung
Hybrid Vehicle Technologies
Ford Research Center Aachen GmbH
Aachen, Germany*



Glossary

B-ISG (belt-driven integrated starter-generator) –
Combines the functions of the starter and the generator.

New European Drive Cycle (NEDC) –
Legally defined drive cycle used to determine levels of toxic emissions and consumption.

Architectures for Safety

A notable trend in automotive systems is combining stand-alone safety applications to make what are called integrated safety systems (ISS). These systems provide safety services that combine and extend current functionality in order to increase the level of safety for vehicle occupants. ISS require advanced electrical and electronic architectures, which have been analyzed and validated in the European research project EASIS (Electronic Architecture and System Engineering for Integrated Safety Systems).

In 2001, the European Commission set itself the ambitious goal of reducing the number of road fatalities by 50% by the year 2010. One of the measures taken to reach this target was the EASIS research project, which ran from 2004 until the end of 2006. EASIS is a partnership of 22 European vehicle manufacturers, automotive suppliers, tool suppliers, and research institutes, who aim to develop technologies for implementing future safety systems.

Requirements Concerning the Platform

An ISS places higher demands on the underlying software and hardware platforms in terms of support for dependability, and requires more rigorous development processes than current systems. To meet the requirements of the hardware platform, we (EASIS project team) developed an on-board electronic hardware infrastructure. For the software platform on

- European research project for future vehicle safety systems
- EASIS validator prototypes and validates main architecture properties
- FlexRay application using dSPACE software and hardware

Integrated Safety Systems

The present generation of safety systems consists mainly of stand-alone systems – confined to their respective domains and with limited interdependency. Combining these systems into integrated safety systems (ISS) with enhanced telematics services will result in two main benefits:

- Information from all domains can be combined to provide a better view of the state of the vehicle and its surroundings, thereby providing a better basis for decisions taken by safety systems.
- The vehicle can be controlled in a more integrated way, as control actions can be coordinated across domains.

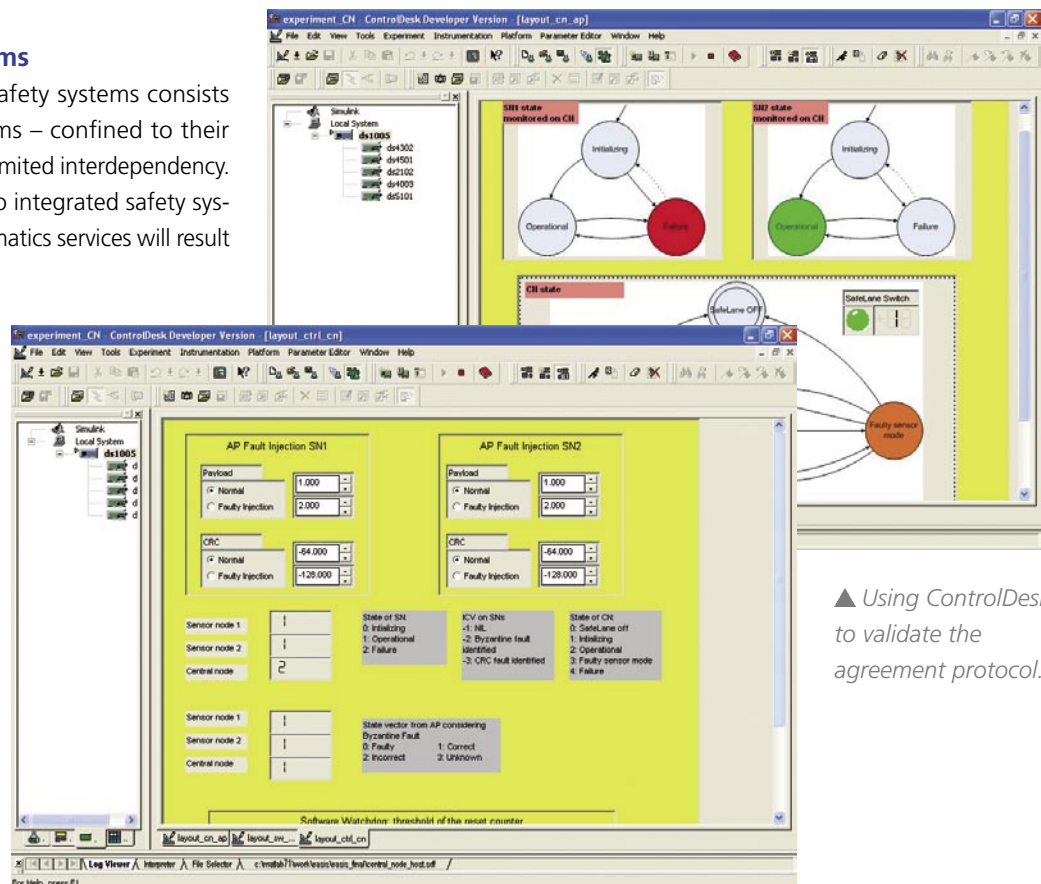

▲ Using ControlDesk to validate the agreement protocol.

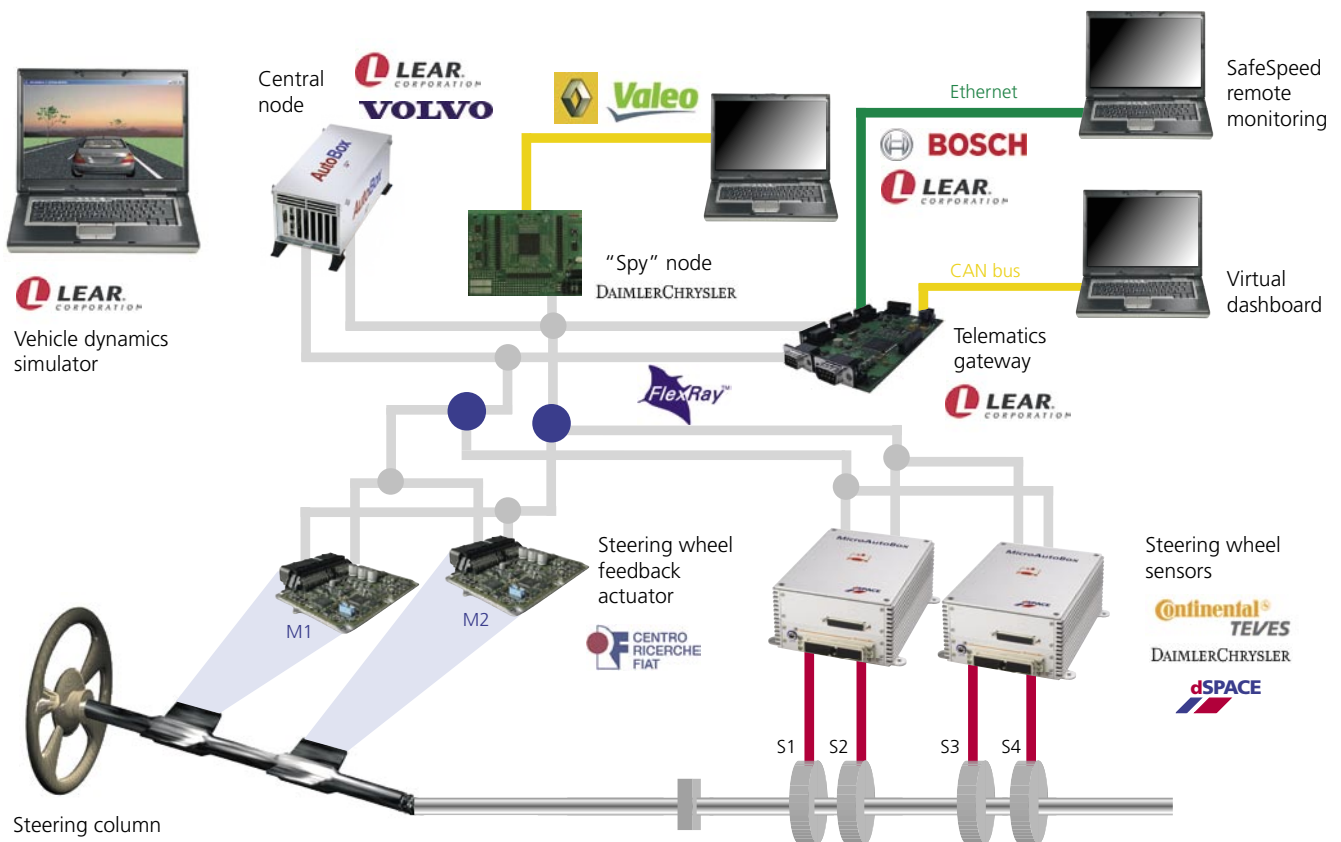

▲ Hardware architecture of the EASIS validator.

which future ISS applications can be built, we identified and described a software architecture with a set of dependable services. For future handling, the specific safety-related results of the project are consistent with the activities of the AUTOSAR partnership.

EASIS Validator

We integrated the main principles defined in the hardware and software platforms into the EASIS validator to show that they are valid and practicable. The validator resembles an automotive electronic system, which includes a telematics gateway, automotive sensors and actuators, and several ECUs. It is a steering system for a lane keeping assistance system (SAFELANE) developed by Volvo as part of the European project PReVENT in combination with a speed limitation option (SAFESPEED). The steering wheel sensor nodes run a sensor application and an agreement protocol that delivers the steering wheel angle value in a fault-tolerant manner. The central node runs the SAFELANE application and the agreement protocol as well. In addition, there is a spy node for fault monitoring and a telematics gateway. A dual-channel FlexRay communication system links the resulting seven nodes together.

Redundancy

The system topology resembles the grouping of fail-silent (FS) electronic control units (ECUs) within different vehicle domains – with a common backbone for exchanging information across these domains realized by the FlexRay communication system. To increase safety, pairs of sensor and actuator nodes have been built to achieve fail operational (FO) units following the principle that if one node fails, the second node will be fully capable of performing the operation required by the application. The actuator

"Everything works well. I am really becoming a fan of your tools."

Antoni Ferre

node is an FO node composed of two fail silent units (FSU) which comply with the hardware development guidelines that resulted from the EASIS project. Each FSU drives an independent actuator to guarantee the full functionality of the system if one of the FSUs fails. We tested this scenario on the validator by injecting several faults and verifying the correct behavior of the system. We generated and fine-tuned the application software on each FSU using dSPACE's production code generator software, TargetLink.

Dependability

To achieve dependability in the software platform, we identified a set of software services that the platform should provide. These services address fault tolerance aspects, the management of information on the state and consistency of the system, and data integrity:

- Agreement protocol: The platform has to provide a service which ensures that the distributed, and partly replicated, components all use the same information as input for decision and control, in order to achieve fail-operational behavior.
- Software watchdogs: They monitor the execution of applications beyond the classical interrupt-on-timeout functionality, for example, by heartbeat monitoring, control flow checking, and task state indication.
- Fault management framework: It provides a consistent and global view of the fault state of the FSU as well as of individual applications on the FSU. This information can be used for isolation and damage assessment purposes as well as to make decisions on appropriate recovery actions.
- Telematics gateway: It hosts EASIS services relating to in-vehicle, inter-domain communications (routing) and external communications (data exchange, remote access).

Realization of the Validator

Several project partners contributed to the EASIS validator, including Lear Corporation (Spain), DaimlerChrysler (Germany), Centro Ricerche Fiat (Italy), and Valeo (France). We chose the system topology in such a way that the final integration performed at Lear Corporation could run smoothly – despite the geographical distribution of the partners and the different time scales for their individual hardware and software developments. The validator development was supported by two MicroAutoBoxes and a modular DS1005 system from dSPACE, all with FlexRay interfaces. Software services running on these systems, and the SAFELANE application, were provided as MATLAB®/Simulink®/Stateflow® models. These models were enriched by the RTI FlexRay Blockset from dSPACE to be linked to the FlexRay communication bus according to the global schedule defined for this project. dSPACE experimentation and test automation

tools were employed to validate the individual services, first locally at each partner's site and then again during integration at Lear. Using the mature development solutions from dSPACE minimized the risks of setting up the validator with a distributed workload. All the activities were completed on schedule, and results were presented at various events in fall 2006, such as the 13th World Congress and Exhibition on Intelligent Transport Systems and Services, London, Great Britain.

Antoni Ferre, Lear Corporation, Spain
Vera Lauer, Xi Chen, DaimlerChrysler, Germany
Fulvio Cascio, Centro Ricerche Fiat, Italy
Luc Fougerousse, Valeo, France
Joachim Stroop, dSPACE, Germany

Glossary

Integrated Safety Systems (ISS) –

A composition of the functions of the vehicle – also integrating telematics, and body and chassis electronics – designed to satisfy road safety objectives, i.e., contain risks within acceptable levels.

EASIS –

Consortium composed of vehicle manufacturers, automotive suppliers, tool suppliers, and research institutes (www.easis.org).

SAFELANE –

Lane keeping assistance system, increasing active vehicle safety by warning the driver if the vehicle drifts too far to one side.

SAFESPEED –

System for automatically limiting vehicle speed to an externally defined maximum value.

PreVENT –

European automotive industry activity co-funded by the European Commission to contribute to road safety by developing and demonstrating preventive safety applications and technologies (www.prevent-ip.org).

Production Projects Under Control

- **New tool for model-based development at system level**
- **Planning, implementing, and integrating complex system architectures**
- **Support of AUTOSAR and generation of AUTOSAR RTE**

Modern electronic control units (ECUs) have such an enormous number of functions, and such a high level of networking, that handling several hundred software components for each ECU is not uncommon. Keeping track of such systems and coping with their complexity is a growing headache for vehicle manufacturers and suppliers. To help them face these challenges, dSPACE has added a new tool to its tool chain for developing automotive software: SystemDesk.

SystemDesk is a new architecture tool designed for model-based development right from system level. Developers working with SystemDesk can easily keep track of the planning, implementation, and integration needed for their complex system architectures and distributed software systems. SystemDesk is intended for vehicle manufacturers and their suppliers: The manufacturers produce the basic design of the distributed ECU software and extract the specifications that are relevant for each supplier. SystemDesk allows

system models to be imported and exported so that manufacturers and suppliers can use and maintain them jointly.

ECU Software Design

The first stage in the development process is the function specification for the electric/electronic system, or functional architecture, which is independent of the real ECUs to come later. Later on, hardware topologies are defined, software modules are distributed on the

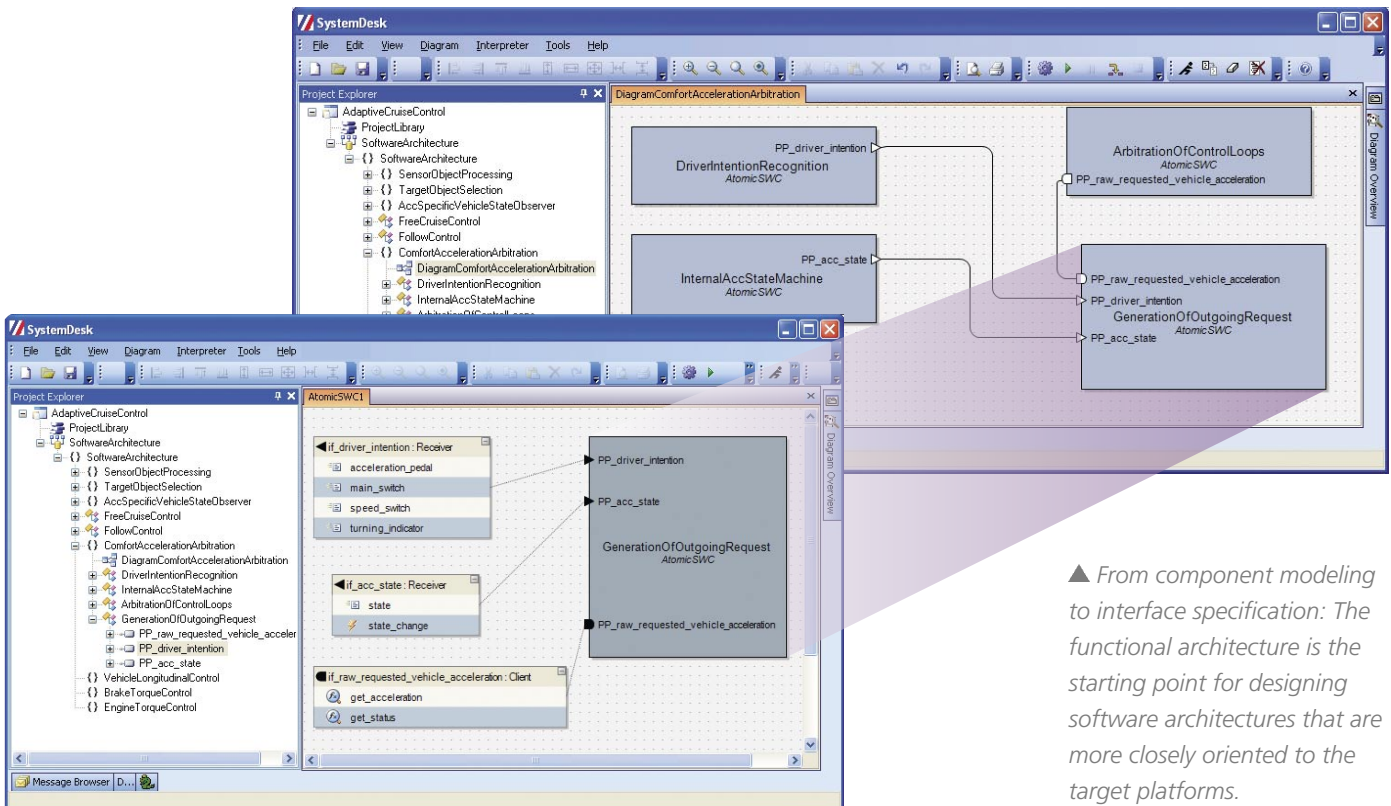

▲ From component modeling to interface specification: The functional architecture is the starting point for designing software architectures that are more closely oriented to the target platforms.

software, and the connections between software and buses are specified.

SystemDesk is designed specially for complex production projects. Such projects require facilities such as the following:

- Libraries for storing reusable objects
- Connection to version control systems
- A scripting-capable tool

To give users clarity even with large-scale models, there are various views of the multi-ECU software architecture, and selective display of model components.

AUTOSAR Firmly Integrated

SystemDesk supports the AUTOSAR standard and others. For example, the interface descriptions of

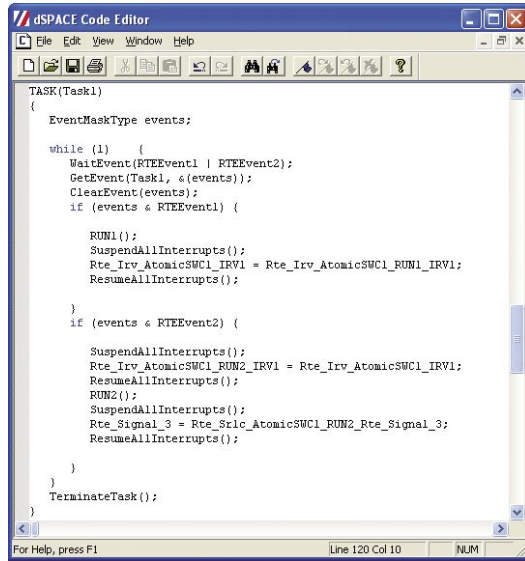

▲ RTE code generated by SystemDesk.

The Ideas Behind SystemDesk

- Master the complexity of the software development process
- Separate different aspects of system modeling, such as function development, software architecture, and hardware topology
- Reuse software components
- Support software exchange and integration
- Generate an AUTOSAR-RTE
- Connect to TargetLink, dSPACE's production code generator, for software component generation

AUTOSAR software components can be created, or existing software components loaded to SystemDesk for further processing. SystemDesk provides a run-time environment (RTE) based on dSPACE's years of experience in code generation and optimization with TargetLink, our production code generator. Software components from SystemDesk can be linked to basic software via standardized interfaces in the RTE generation.

Connecting to TargetLink

SystemDesk works hand in hand with the TargetLink tool, which can be used to generate production code for the software components in SystemDesk architecture models. Function design is done with established tools such as Simulink®/Stateflow®, which are closely

integrated with TargetLink and also SystemDesk. A special TargetLink AUTOSAR module allows the generation of AUTOSAR-compliant production code.

Complete Tool Chain

SystemDesk expands dSPACE's already extensive tool chain for developing and testing ECU software. The first version of SystemDesk is planned for release in summer 2007.

Glossary

Software component –

Formal description plus implementation of a software module. The description comprises items such as ports, interfaces, data types, and C code. The use of communication macros and the formal description means that software components are easy to reuse.

Run-time environment (RTE) –

Automatically generated, optimized C code that implements communication between the software components and the function scheduling. It also provides the connections between software components and I/O interfaces. Exactly one RTE is generated for each ECU.

Bypassing with CCP

- Bypassing with CCP ECUs
- Minimum implementation work
- Real-time data capture in ECU tests

Electronic control units (ECUs) frequently have a CCP implementation (CAN Calibration Protocol) for measurement and calibration tasks. With the new Real-Time Interface (RTI) Bypass Blockset 2.2 from dSPACE, an existing CCP implementation can also be used for function bypassing. Only minor modifications to the ECU code are required for this, or even none at all. Due to its minimized implementation effort, bypassing via CCP is a cost-effective approach, particularly where a bypass scenario does not need the performance with regard to latencies between ECU and prototyping system that would be provided, for example, by XCP on CAN.

Used together with the new RTI Bypass Blockset 2.2 from dSPACE, an existing CCP implementation in an ECU opens up a wide range of application options:

Function bypassing with minimum modifications to ECU code

To prepare certain functions in the ECU code for bypassing, only small code modifications are necessary to guarantee the consistency of data written to the ECU. No service implementation is needed. The

prototyping system, for example, MicroAutoBox, can capture the input variables of the functions to be bypassed from the ECU via CCP upload or CCP DAQ mechanisms. The prototyping system executes the bypass functions in real time and writes the values of the function outputs back to the ECU via CCP download. The consistency of the downloaded data can be ensured by appropriate modifications to the ECU code. dSPACE provides an example implementation for this.

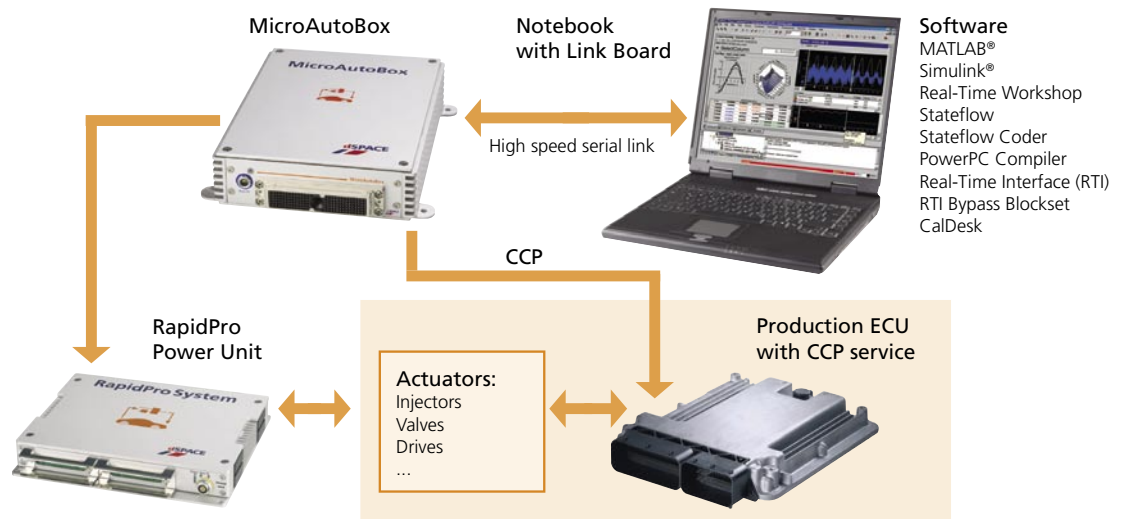

▲ Function bypassing with no modifications to ECU code. Inputs to the bypass function are captured via the CCP DAQ mechanism, and the outputs are connected directly to the actuators via RapidPro.

Function bypassing with no modifications to ECU code

A typical approach to developing new ECU functions is to capture the input variables of the bypass function on the ECU via the DAQ mechanism, then calculate the function in real time on the prototyping system, and couple the function outputs directly with the corresponding actuators in the vehicle via power stages in a RapidPro Power Unit. An alternative is to open up the ECU-internal signal path for controlling the actuators, for example, via dedicated diagnostic services, and write the outputs directly via CCP download to the memory location of the actuating variables.

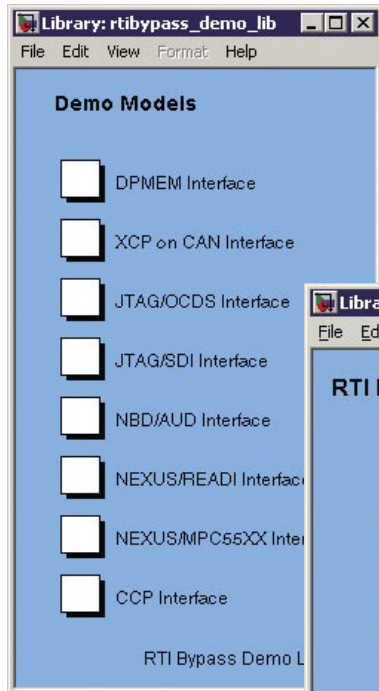

▼ RTI Bypass Blockset 2.2 for dialog-based configuration of bypass interfaces: now bypassing via CCP is also supported.

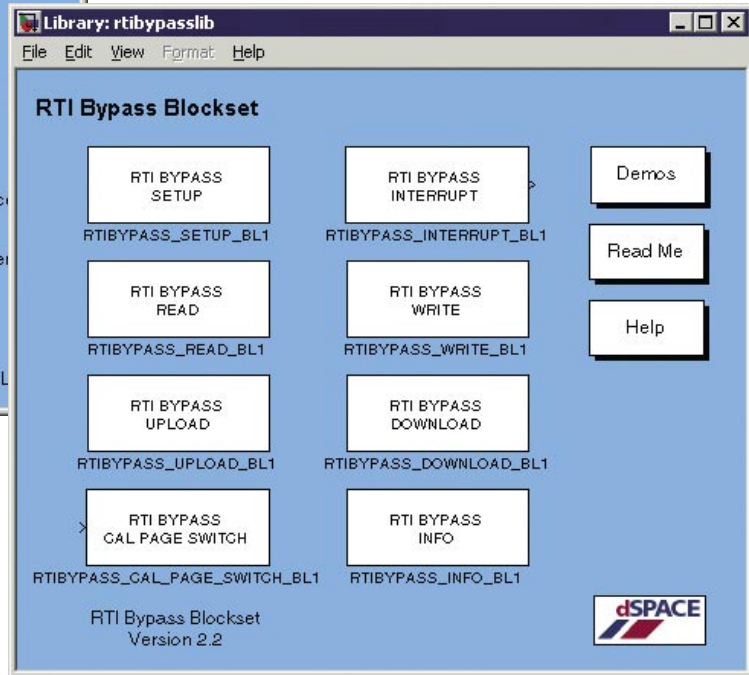

Measurement of ECU variables on real-time platforms in ECU tests

RTI Bypass Blockset 2.2 supports a variety of real-time platforms (MicroAutoBox, DS1005, DS1006) and I/O boards (DS4302) from dSPACE. Support for DS2202 and DS2211 is under development. Thus, it will become possible to capture ECU-internal data on hardware-in-the-loop (HIL) systems in real time via CCP.

ECU, it is usually unnecessary to integrate another service for the bypass task, so that time and costs can be saved.

Features of CCP

CCP is particularly suitable for bypass scenarios whose latency requirements are not so tough, or that do not permit modification to the ECU code. Unlike XCP on CAN, which provides the data stimulation method (STIM), CCP has no options within the protocol for transmitting data to the ECU synchronously. With CCP, every single value needs a CCP download instruction to be transmitted, and an acknowledgement from the ECU is required each time. This causes – compared to XCP on CAN – higher latencies in writing the output values from the bypass function to the ECU. However, if a CCP implementation is already available on the

Glossary

Bypass service –

Software modifications in an ECU that make the input variables for the bypass function available to the RCP system, and that trigger the calculation of the bypass function. When the RCP system returns the function output variables, the bypass service feeds them back into the ECU's program sequence.

DAQ mechanism –

Method of synchronous capture of measurement data in an ECU. Has a low protocol overhead, as no address data has to be transmitted with the measurement data during a running measurement.

Variable Editing Made Easy

- Variable Editor for editing ECU description files
- Stand-alone or integrated in CalDesk or the RTI Bypass Blockset
- ECU description files according to ASAM-MCD 2MC

One of the innovations in dSPACE Release 5.2 is the Variable Editor, a tool that makes it easy to create and edit electronic control unit (ECU) description files according to the ASAM-MCD 2MC standard. The Variable Editor is very versatile: It can be used as a stand-alone tool and also as an integrated component in CalDesk, the measurement and calibration software, or in the RTI Bypass Blockset.

ECU Description Files

An ECU description file contains information on measurement and calibration variables. This includes the memory addresses of variables, conversion methods, memory layout and data structures in the ECU, and the communication parameters for the calibration interface. To be independent of any specific calibration

tool, an ASAM-MCD 2MC (ASAP2)-compliant ECU description file ensures the standardized exchange of ECU description data between the tools involved in the development process. ASAM-MCD 2MC is accepted as a de-facto standard by broad sections of the automotive industry.

What Is the Variable Editor For?

The Variable Editor can be used to visualize and edit ECU description files, and to create completely new ones. It also lets you import any desired number of ECU description files, to copy function groups or individual variables, and to export new ECU description files. This makes it

▼ *The Map File Manager in the Variable Editor allows one or more linker map files to be assigned to an ECU description file.*

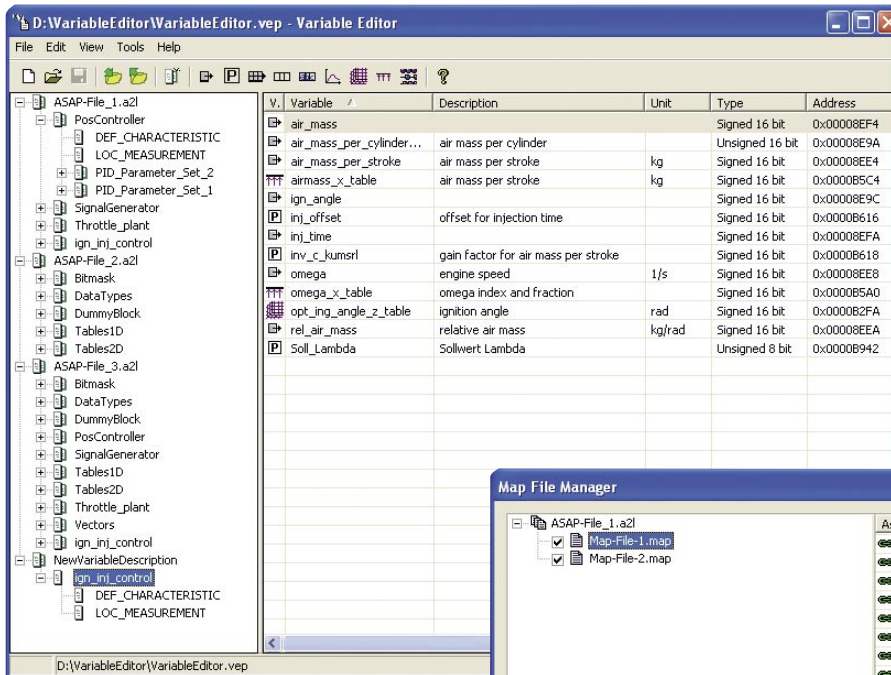

▲ *The Variable Editor, shown here with several imported ECU description files. Function groups and variables can be exchanged between files in any way required, making it possible to create tailor-made ECU description files.*

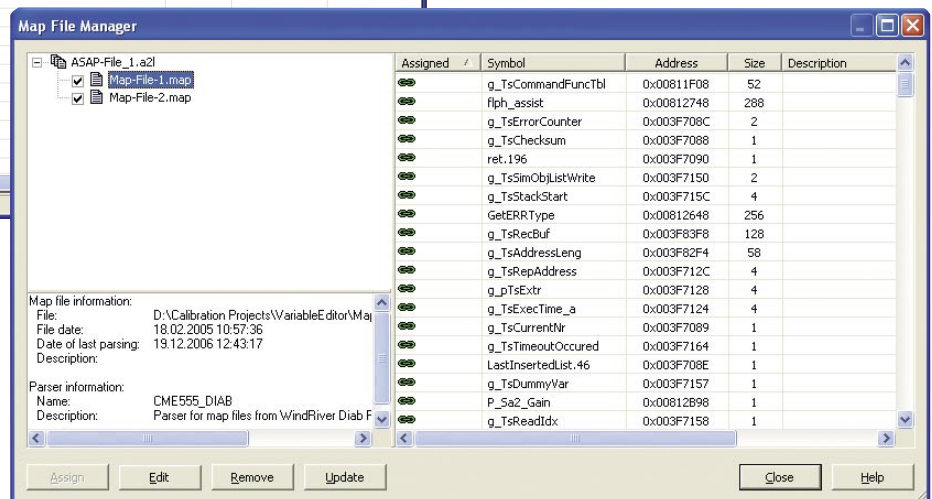

easy to bring variables together from existing description files, and to create subsets from the entire stock of variables. The integrated Map File Manager is used to assign one or more linker map files to an ECU description file and to update address information at a click. The Map File Manager also makes it quick and simple to create new ECU descriptions based on map files.

When you use the Variable Editor, you can also select variables that were just created or modified and export them, and integrate them into existing ECU description files via appropriate import options.

Stand-Alone, or Integrated in CalDesk or the RTI Bypass Blockset

You can use the Variable Editor as a stand-alone tool, or just as easily call it straight from the CalDesk measurement and calibration software or the RTI Bypass Blockset. It is then a fully integrated component with context-adapted menus; the available functions also adjust to the context. Variable Editor

functions that are not needed with CalDesk or the RTI Bypass Blockset are automatically hidden. To access the entire functionality of the Variable Editor, you need a separate license. The functions for creating "calculated variables" can be accessed without a license.

Calculated Variables

You can use the Variable Editor to define calculated variables, as they are called. These are variables that are derived from other variables by means of definable computation formulas. A convenient Formula Editor is available for you to design the necessary calcula-

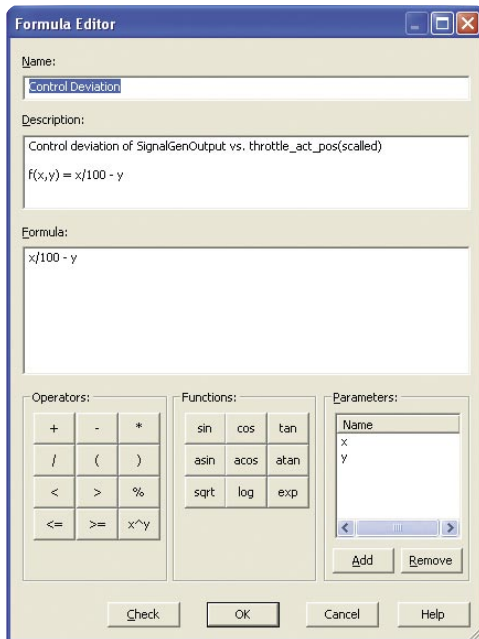

▲ The Formula Editor for defining computation methods for calculated variables.

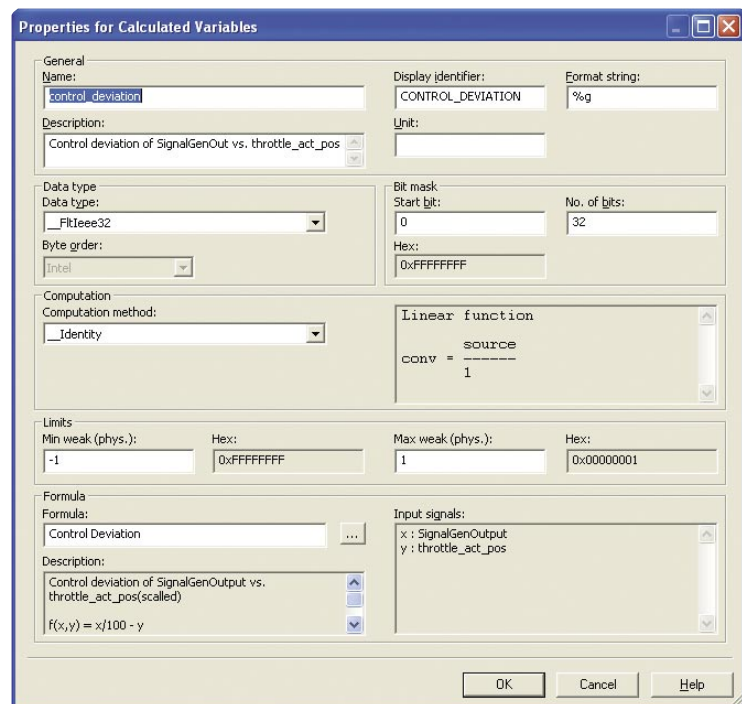

▲ Configuration dialog for calculated variables.

tion methods. Variables defined and calculated in this way can be connected to instruments in CalDesk and recorded in measurement files just like normal variables. Calculated variables and computation formulas can be collected in a pool to make them available to other projects.

ASAM

ASAM stands for Association for Standardisation of Automation- and Measuring Systems. ASAM is a registered society under German law (ASAM e. V.). Its members are mainly German automobile manufacturers, and their suppliers and service providers, but

also companies from the rest of Europe, the USA, and Japan, with several German universities and also individual people. The goal of the society is to standardize interfaces, protocols, and data formats for automobile construction, with the main focus on electronics. For more information, visit www.asam.net.

Single-Source Testing and Diagnostics

- Remote control of CalDesk diagnostics via AutomationDesk
- Complies with ASAM-MCD 3D (Version 2.0.1)
- ODX-based diagnostics

Diagnostics and hardware-in-the-loop (HIL) testing are brought together in Version 1.4 of AutomationDesk, our test management software. You can now use AutomationDesk to remote-control and automate the diagnostics functionality of CalDesk, our universal measurement and calibration software. This means you have a completely integrated tool chain for HIL testing, ECU calibration, measurement tasks, and diagnostics from a single source, and difficult compatibility problems are a thing of the past.

Diagnostics and HIL Testing Come Together

Successful integration of ECU diagnostics into the hardware-in-the-loop (HIL) testing of ECU software is increasingly important. One reason is that diagnostics software is a vital component of the overall software, and has to undergo the same quality assurance procedures as any other application software. Another reason is that it is an aid to HIL testing: for example,

New Remote Control for Diagnostics with CalDesk

AutomationDesk 1.4 can now be used to automate and remote-control CalDesk's ODX-based diagnostic functionality, as well as for automating measurement and calibration tasks as previously. AutomationDesk 1.4 accesses CalDesk via the ASAM-MCD 3D automation interface. You can build test sequences graphically in the familiar way in AutomationDesk, using the new CalDesk ECU Diagnostics Access Library.

This is an AutomationDesk library of the blocks needed for automating access to CalDesk's diagnostic functionalities.

All Tools from One Source

By using CalDesk and AutomationDesk, you avoid the difficult compatibility problems that often arise in practice when tools from different vendors have to be integrated. dSPACE

offers you HIL systems plus measurement, calibration, and diagnostic tools from a single partner, with no complications. The smooth interaction between AutomationDesk and CalDesk is the basis for successful HIL testing.

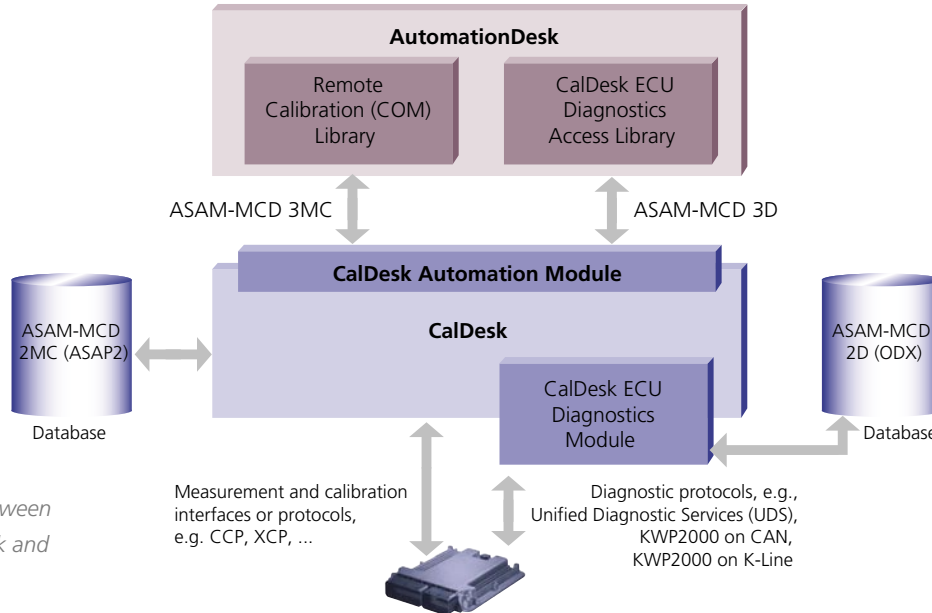

► Interfaces between AutomationDesk and CalDesk.

it can be used to automate the reading and clearing of an ECU's fault memory from within a test scenario. AutomationDesk is a standard solution for automated HIL testing that can address a variety of software tools: These include CalDesk, the measurement, calibration, and diagnostic tool; and diagnostic tools such as DTS and EDIABAS from Softing, and VAG Tester and DiagRA from RAConsult.

Innovations in Release 5.2

Real-Time Testing with AutomationDesk 1.4

For hardware-in-the-loop (HIL) simulations that require maximum timing precision, AutomationDesk offers a new solution in the form of Python scripts. These run on the processor of the HIL system in real time, synchronously to the model, so that test actions can also be performed on a real-time basis.

Easy Handling of Large LIN Setups

The new RTI LIN MultiMessage Blockset is used to check and configure all standard and diagnostic frames from a Simulink® block. This reduces model size and also cuts the time taken by code generation and the build process. The blockset can be used both for rapid control prototyping and for HIL simulation, and supports the LIN 1.3 and LIN 2.0 standards.

ControlDesk 3.0 with CAN Navigator

The CAN Navigator integrated in ControlDesk 3.0 visualizes the CAN bus communication in simulation

models, thereby bridging the gap between implementation and experiment software. Users therefore have both improved visualization and faster access to messages and signals.

Bypassing via CCP

RTI Bypass Blockset 2.2 has new features for function prototyping by means of bypassing, allowing a CAN Calibration Protocol (CCP) implementation already available in the electronic control unit (ECU) to be used. The bypass hook requires very little modification to the ECU code, or even none at all.

AUTOSAR with TargetLink 2.2

TargetLink 2.2 supports the model-based design of AUTOSAR ECUs, thereby providing the transition from behavior model to AUTOSAR software component. In addition, users can now simply click to navigate between model blocks and associated code patterns in both directions, which considerably facilitates code and model reviews.

- **dSPACE Release 5.2 available on DVD**
- **New product versions**
- **Extended Functions and Application Areas**

For more information, visit www.dspace.com/goto?releases

TV Summer 2006

Temperatures for dSPACE customers and employees in the northern hemisphere are currently rather on the low side. So what could be nicer than to look back at summer 2006, when we had brilliant weather to

"We never thought we would get as big as we are now. We couldn't foresee that our customers would require the quantity of things that we make today. It's good that it's like that, but you have to work hard to make sure it stays that way."

**Dr. Herbert Hanselmann,
dSPACE founder and President**

enjoy not only an exciting FIFA World Cup, but also – we think – an exciting TV report on dSPACE. One of Germany's largest and most successful TV stations, ZDF, broadcast live from dSPACE's Paderborn facilities.

Presenter Ralph Goldmann's probing interviews gave viewers an intriguing glimpse behind the scenes at dSPACE. The program included reports and interviews, and showed how dSPACE, as a medium-sized company, became "world champion" in vehicle software in the age of globalization.



For the complete report, please see www.dspace.com/goto?ZDF_e

French User Conference

➤ **dSPACE users from France came together**

➤ **5 years of dSPACE presence celebrated**

➤ **Innovative customer projects using dSPACE products**

The User Conference in France was held on October 12, 2006 under the theme "Les Rencontres Electronique et Automatique 2006" (Electronics and Automation Meetings 2006). More than 100 participants met at the Sofitel Hotel at Porte de Sèvres in Paris and presented their projects. The day was also the occasion to celebrate 5 years of dSPACE in France.

Attendees from Automotive and Aeronautical Industries, and Universities

More than 100 participants from 40 different companies came to attend this day of exchanges and meetings on electronic control system development.

Large companies in the French automotive and aeronautical industries were represented, as well as universities involved in the research and the development of embedded electronics. Users from Renault, PSA Peugeot Citroën, VALEO, VOLVO 3P, EADS ASTRIUM, Thalès, Siemens VDO Automotive, Delphi Diesel Systems, Hispano-Suiza, SUPELEC, Polytech' Nantes, Liebherr Aerospace, ESTACA, Messier-Dowty, etc., attended the conference.

▼ *Dr. Salah Aksas welcoming the attendees in the presentation hall.*



Welcome and Agenda

Dr. Salah Aksas, Director of dSPACE Sarl, welcomed the attendees and gave an overview of dSPACE's activities in France during its five years. Dr. Herbert Hanselmann, President



▲ *More than 100 participants listened to the presentations.*

of dSPACE GmbH, explained the current product portfolio and presented important applications developed with dSPACE products. He pointed out that OEMs and suppliers are heavily investing in hardware-in-the-loop (HIL) simulation because of the huge benefits it brings.

"dSPACE won't let you down when problems arise. They really help you."

Customer on his experience with dSPACE

For example, Audi has shown improvements in warranty cost by more than a factor of two in just a few years, and this can largely be credited to rigorous HIL testing. Increasingly, large simulators for complete vehicles are used to cope with the complexity of multiple CAN, LIN and FlexRay networks in a modern car. DaimlerChrysler is using such systems intensively and has achieved excellent software quality in recent product launches.

Overview of Presentations

"Fullpass prototyping for engine controls": Natalia Lestrée, PSA Peugeot Citroën, explained their mission to rely on a

► *Dr. Herbert Hanselmann gave insights into dSPACE's development work and the current product portfolio.*





◀ At the rally slot, racing customers faced the challenge of controlling cars that could reach 60 km/h.

turn-key RCP solution to validate new innovative engine control concepts on a real engine test bench.

“Development of complete applications with TargetLink”: Denis Eperonnier, Valeo Thermique Habitable, generated all the fixed-point application code for a climate control with TargetLink. “Use of dSPACE

“TargetLink code is 30% to 40% more efficient for some models than code generated with other production code generators on the market.”

User statement during TargetLink presentation

facilities to descend and ascend the V-cycle with regard to StARS alternator-starters”: Sébastien Roue, Valeo Systèmes Electriques, implemented a well thought-through test concept based on AutomationDesk. The team appreciated the fact that dSPACE solutions could easily be extended to meet new requirements. “HIL bench for Volvo 3P Light Duty”: Nicolas Bellot,

“dSPACE’s test automation solutions are superior to other products on the market.”

User talking about dSPACE tools

Volvo 3P; Damien Brunel, Sherpa Engineering, described how the engine and ABS ECUs were tested together with a dSPACE Simulator. Thus the behavior of one ECU could be checked when a failure is inserted on a sensor of the other.

“Calibration of transmission automated with dSPACE Calibration System/CalDesk”: Laurent Chapus, Segula,

explained how CalDesk meets all the requirements of calibration projects on production transmission ECUs. They will now use CalDesk for new calibration projects with OEMs. The quotations highlighted in this article contain some of the core statements made in the presentations. Product Managers from dSPACE and members of the dSPACE France team presented new product features and described the trends in the areas of FlexRay and AUTOSAR. An evening program rounded the day off with good entertainment, lots of conversations, and much fun.

Merci!

The entire dSPACE team would like to thank you for participating in the Rencontres Electronique et Automatique 2006. We hope you learned more about tools and solutions, and had the chance to get new ideas for the development of your embedded applications. We particularly thank those who agreed to present their applications, which made the day so successful and pleasant. We are happy to be able to accompany you in your projects.

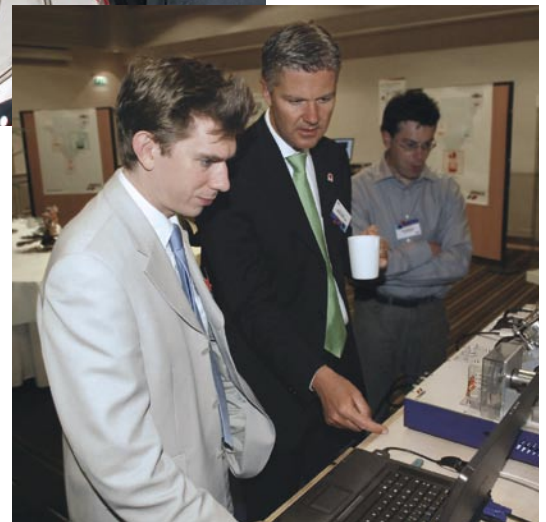

▲ Hands-on during the breaks – everybody could immediately try out the products.

For more details on the presentations, please visit www.dspace.fr/goto?REA06

DS1006 with 3-GHz Processor

Especially for customers who need extremely high processing power in their real-time hardware, dSPACE now also offers the DS1006 Processo-Board with an AMD Opteron™ Processor at 3 GHz clock rate, in addition to the 2.6-GHz version already available. In view of AMD's current delivery guarantee, the new DS1006 variant will probably be available only till the

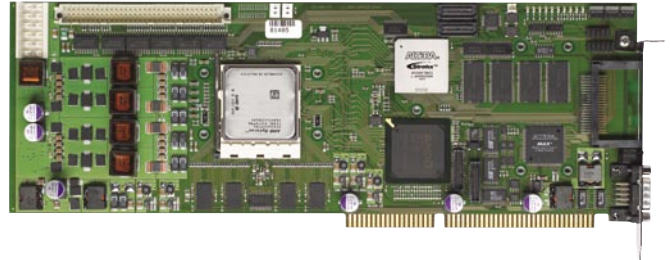

end of 2007, so the previous version with the 2.6 GHz processor will continue as part of dSPACE's product range. dSPACE will retrofit the new 3-GHz processor to older DS1006 boards at customers' request.

New in CalDesk 1.4

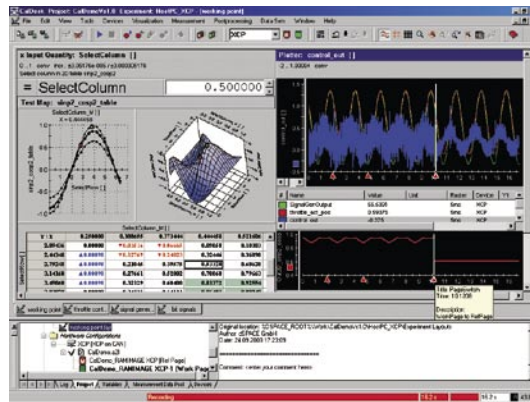

dSPACE Release 5.2 (see page 35) includes version 1.4 of CalDesk, the measurement and calibration software. The new Variable Editor lets you create, visualize, and edit description files for electronic control units (ECUs) directly from CalDesk (see page 32). Another new feature is that CalDesk now displays ASAM-MCD 2MC (ASAP2) project data in the Project and Experiment Navigator, making it easier to handle projects and experiments. The Plotter instrument for graphical signal display has been extended and can now show signal behavior both over time and against other signals.

FlexRay Product Day

FlexRay is well set to become a new communication standard for automotive electronics. The FlexRay Product Day, organized by the Carl Hanser publishing house, gives users and tool suppliers for the FlexRay bus system the chance to meet and share information.

The FlexRay Product Day held on November 30, 2006, focused on projects presenting the first actual production vehicles containing FlexRay. Participants also discussed upcoming tasks of the FlexRay Consortium, innovative FlexRay products, and new tools for developing FlexRay products. Joachim Stroop,

Product Manager at dSPACE, presented the dSPACE tool chain for developing and testing FlexRay applications.



Events



EUROPE

Embedded World 2007

February 13-15, Nuremberg, Germany
<http://www.embedded-world-2007.de>

IET – Automotive Electronics

March 7-8, Coventry, United Kingdom
<http://conferences.theiet.org/autoelec>

RTS – EMBEDDED SYSTEMS

March 6-8, Paris La Défense 92, France
<http://www.birp.com/rts2007>

Aerospace Testing Expo

March 27-29, Munich, Germany
<http://www.aerospacetesting-expo.com/europe>

Automotive Testing Expo

May 8-10, Stuttgart, Germany
<http://www.testing-expo.com/europe>

USA

SAE Hybrid Vehicle Technologies

February 7-8, San Diego, CA, USA
<http://www.sae.org/hybrid>

SAE World Congress 2007

April 16-19, Detroit, MI, USA
<http://www.sae.org/congress/>

Asia

AES – Automotive Electronics Summit 2007

April 25-27, Shanghai, China
http://www.gracefair.com/ae_home.htm

ESEC – Embedded System Expo & Conference

May 16-28, Tokyo, Japan
<http://www.esec.jp/ESECI/en>

dSPACE Japan K.K. User Conference

May 22, Shinagawa, Tokyo, Japan
<http://www.jsae.or.jp>

JSAE 2007

May 23-25, Yokohama, Japan
<http://www.jsae.or.jp>

For further events, please visit www.dspace.com

Request Infos



Please check the corresponding field on your response card and return it

- ✦ By mail
 - ✦ By fax to +49 52 51 – 6 65 29 or
 - ✦ Request information via our Website
www.dspace.de/goto?dspace-news-info
- Your opinion is important. Please send your criticism, praise, or comments to dspace-news@dspace.de – thank you!

Job Opportunities



Due to our continuous growth, dSPACE is looking for engineers in

- ✦ Software development
- ✦ Hardware development
- ✦ Applications
- ✦ Technical sales
- ✦ Product management

Current offers at www.dspace.com/goto?jobs

Papers



“Adding Value to ECUs”

André Rolfmeier, Ortwin Ludger Franzen, dSPACE GmbH

“Transforming Function Models into AUTOSAR Software Components”

Michael Beine, Ulrich Eisemann, dSPACE GmbH

Trainings



dSPACE offers training on these topics:

- ✦ dSPACE Real-Time Systems
- ✦ ControlDesk
- ✦ RapidPro
- ✦ Rapid Control Prototyping with CalDesk
- ✦ TargetLink
- ✦ Hardware-in-the-Loop Simulation
- ✦ AutomationDesk
- ✦ MotionDesk
- ✦ RTI CAN MultiMessage Blockset
- ✦ Automotive Simulation Models
- ✦ CalDesk

For more information, please visit www.dspace.com/goto?training

Australia

CEANET Pty Ltd.
Level 5, 15 -19 Bent Street
Sydney NSW 2000
Australia
Tel.: + 61 2 9232 3699
Fax: + 61 2 9232 3332
info@ceanet.com.au
www.ceanet.com.au

China and Hong Kong

HiRain Technologies
8F Tower B
Beijing Venture Plaza No.11
Anxiang Beili Chaoyang District
Beijing China, 100101
Tel.: +86 10 648 40 606
Fax: +86 10 648 48 259
xmcao@hirain.com
www.hirain.com

Czech Republic and Slovakia

HUMUSOFT s.r.o.
Pobrezni 20
186 00 Praha 8
Tel.: +420 2 84 01 17 30
Fax: +420 2 84 01 17 40
info@humusoft.cz
www.humusoft.cz

India

Cranes Software Intern. Ltd.
#29, 7th Cross, 14th Main
Vasanthnagar
Bangalore 560 052, India
Tel.: +91 80 22381740
Fax: +91 80 22384317
dspace@cranessoftware.com
www.cranessoftware.com

Korea

MDS Technology Co., Ltd.
15F Kolon Digital Tower Vilant 222-7
Guro-3-dong, Guro-gu
Seoul 152-848, South Korea
Tel.: +82 2 2106 6000
Fax: +82 2 2106 6004
dspace@mdstec.com
www.mdstec.com

Netherlands

TSS Consultancy
Rietkraag 37
3121 TC Schiedam
Tel.: +31 10 2 47 00 31
Fax: +31 10 2 47 00 32
info@tsscon.nl
www.tsscon.nl

Poland

Technika Obliczeniowa
ul. Obozna 11
30-011 Kraków
Tel.: +48 12 630 49 60
Fax: +48 12 632 17 80
info@tobl.krakow.pl
www.tobl.krakow.pl

Sweden

Fengco Real Time Control AB
Svärdvägen 25A
SE-182 33 Danderyd
Tel.: +46 8 6 28 03 15
Fax: +46 8 96 73 95
sales@fengco.se
www.fengco.se

Taiwan

Scientific Formosa Incorporation
11th Fl. 354 Fu-Hsing N. Road
Taipei, Taiwan, R.O.C.
Tel.: +886 2 2505 05 25
Fax: +886 2 2503 16 80
info@sciformosa.com.tw
www.sciformosa.com.tw

Headquarters in Germany

dSPACE GmbH
Technologiepark 25
33100 Paderborn
Tel.: +49 5251 1638-0
Fax: +49 5251 66529
info@dspace.de

USA and Canada

dSPACE Inc.
28700 Cabot Drive
Suite 1100
Novi · MI 48377
Tel.: +1 248 567 1300
Fax: +1 248 567 0130
info@dspaceinc.com

France

dSPACE Sarl
Parc Burospace · Bâtiment 20
Route de la Plaine de Gisy
91573 Bièvres Cedex
Tel.: +33 1 6935 5060
Fax: +33 1 6935 5061
info@dspace.fr

Japan

dSPACE Japan K.K.
West Tower 9F
Yokohama Business Park
134 Godo-cho · Hodogaya-ku
Yokohama-shi
Kanagawa-ken 240-0005
Tel.: +81 45 338 3361
Fax: +81 45 338 3362
info@dspace.jp

United Kingdom

dSPACE Ltd.
Unit B7 · Beech House
Melbourn Science Park
Melbourn
Hertfordshire
SG8 6HB
Tel.: +44 1763 269 020
Fax: +44 1763 269 021
info@dspace.ltd.uk

