

The Joined Wing



AFRL, Boeing and NASA: success in
wind tunnel testing of Joined-Wing
SensorCraft vehicle



Photo credits: NASA

A goal of the Air Force Research Laboratory's Sensor-Craft project is to develop technologies for future high-altitude, long-endurance unmanned surveillance platforms. A component of this research project intended to develop technologies relevant to these large, flexible vehicles was the Aerodynamic Efficiency Improvement (AEI) program. The goals of the AEI program included the demonstration of flutter suppression, gust load alleviation (GLA), and reduced static margin, which are potentially enabling technologies for a SensorCraft vehicle that will allow it to have reduced structural weight, thereby increasing endurance, range, and payload capacity. The AEI program included a series of wind tunnel tests of two Sensor-Craft designs in the NASA Transonic Dynamics Tunnel. The configurations tested were a flying wing and a joined wing (shown in figure 1) described in references 1 and 2, respectively. Each configuration required a model support that provided rigid body degrees of freedom. The need to include rigid body degrees of freedom required the models to be 'flown' in the wind tunnel which added a great deal of complexity and risk to the project. The wind tunnel tests of these models were successfully and safely completed using two digital controller systems, one for the flight control laws and the other for the servo control loops, WatchDog system, and emergency control law. This article describes the controls' architecture and implementation using dSPACE systems, focusing on the joined-wing test. The test team included the Air Force Research Lab (AFRL), The Boeing Company, and the NASA Langley Research Center. >>

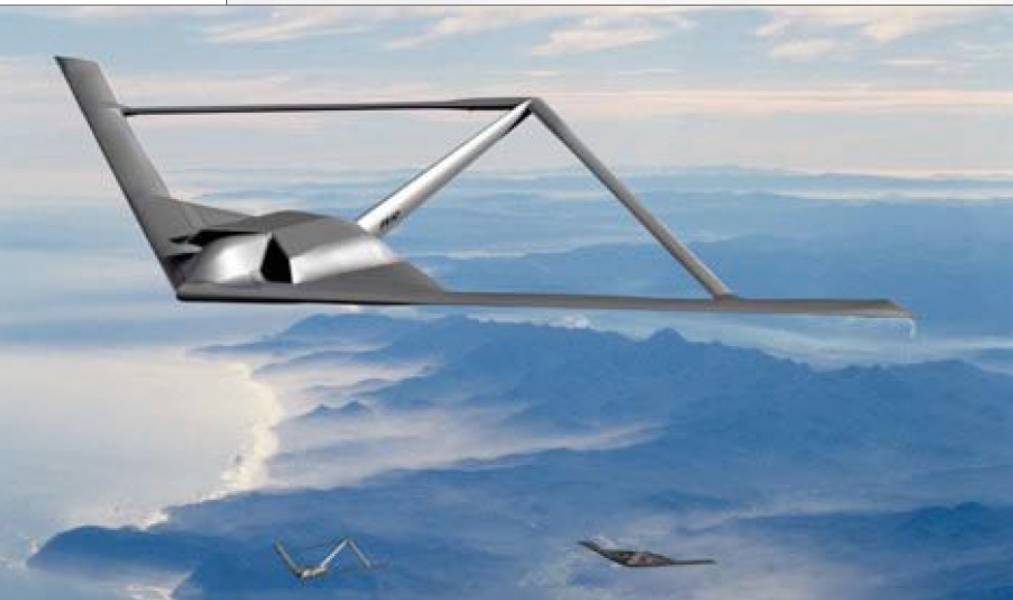

Figure 1: Joined-Wing SensorCraft configuration.

Experimental Setup

The Joined-Wing SensorCraft (JWS) tests were conducted in the NASA Langley Transonic Dynamics Tunnel (TDT). The TDT is a unique national facility dedicated to identifying, understanding, and solving relevant aeroelastic and aeroservoelastic problems. The TDT is a closed-circuit, continuous-flow, variable-pressure wind tunnel with a 16-foot square test section with cropped corners. The tunnel uses either air or

a heavy gas as the test medium and can operate over a Mach number range from near zero to 1.2. The TDT is specially configured for flutter testing, with excellent model visibility from the control room and a rapid tunnel shutdown capability for model safety. The TDT has an Airstream Oscillation System to generate simulated gusts that was used extensively for this series of wind tunnel tests. Figure 2 shows an illustration of the JWS and the support system.

Figure 2: Illustration of the AEI Joined-Wing SensorCraft model mated to a two-DOF support system installed in the NASA Langley TDT.

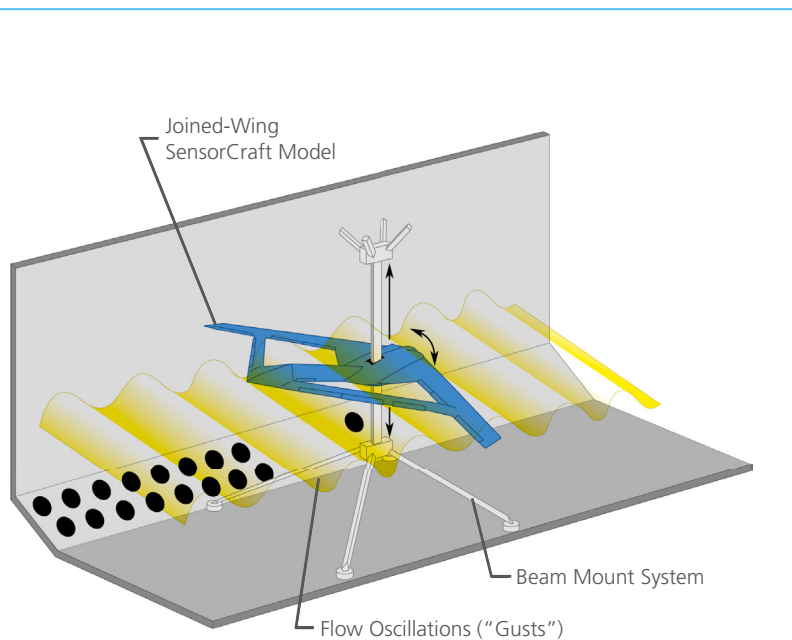

The pitch and plunge degrees of freedom are indicated by the two arrows.

Figure 3 shows a photo of the JWS model installed in the TDT. The support system is comprised of a beam and carriage, and for safety, the carriage was equipped with a plunge brake and pitch displacement limiter to remotely lock out rigid body motion. The model was also equipped with a large instrumentation suite consisting of accelerometers, strain gages, rate gyros, potentiometers, and a total of 13 hydraulically actuated, high-bandwidth control surfaces, each with a Rotary Variable Differential Transformer (RVDT) position sensor. The control surfaces were located on the trailing edges of the wings with six each on the forward and aft wings and a rudder. External to the JWS wind-tunnel model, a variety of components had to be integrated to support the test. These included two dSPACE digital control systems, a commercial signal conditioning system, custom signal conditioners for the RVDTs and the Moog servo valves, various power supplies, and a custom snubber control system. A schematic showing how the wind-tunnel model and the various systems were connected is shown in figure 4. The signals external to dSPACE units are all analog signals. The anti-aliasing filters were set to 400 Hz for the RVDTs, as they were routed only to a digital control system running at a 1,000 Hz frame rate (dSPACE 1). All other signals were filtered at 100 Hz to be compatible with the other digital control system running at a 200 Hz frame rate (dSPACE 2). Data were acquired using the TDT Data Acquisition System (DAS) sampling at 500 Hz.

Control Systems

The control tasks for the JWS wind-tunnel test were divided between two dSPACE systems. The servo control loops for positioning the control surfaces using the RVDTs, servo valves and the WatchDog system

were both implemented on dSPACE 1, while dSPACE 2 was used for flight control (trim and GLA). The snubber control system was custom built to support this wind tunnel test, and it consists of a latching circuit, several switches, and a power supply. The snubber control system combined with solenoid valves and hydraulic actuators onboard the model was used to lock out the rigid body motion. This system could be tripped manually, but this feature was never used. Instead, the automated WatchDog system running on dSPACE 1 reliably issued the "Snub!" command to keep the model safe. Key features of the two dSPACE systems and the snubber control system are shown in figure 5. User input to these systems is shown in dark gray. The gust load alleviation and trim control laws were implemented within the flight control block on dSPACE 2. This flight control block included a GUI interface and programming logic for controlling or initiating certain events like resetting the system or initiating a takeoff

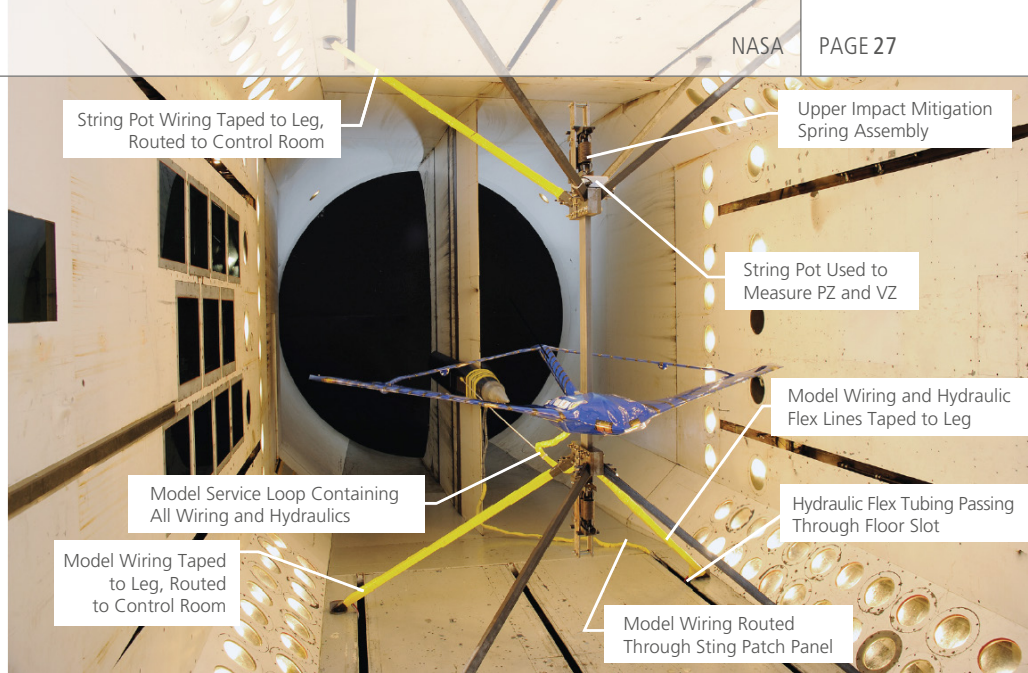
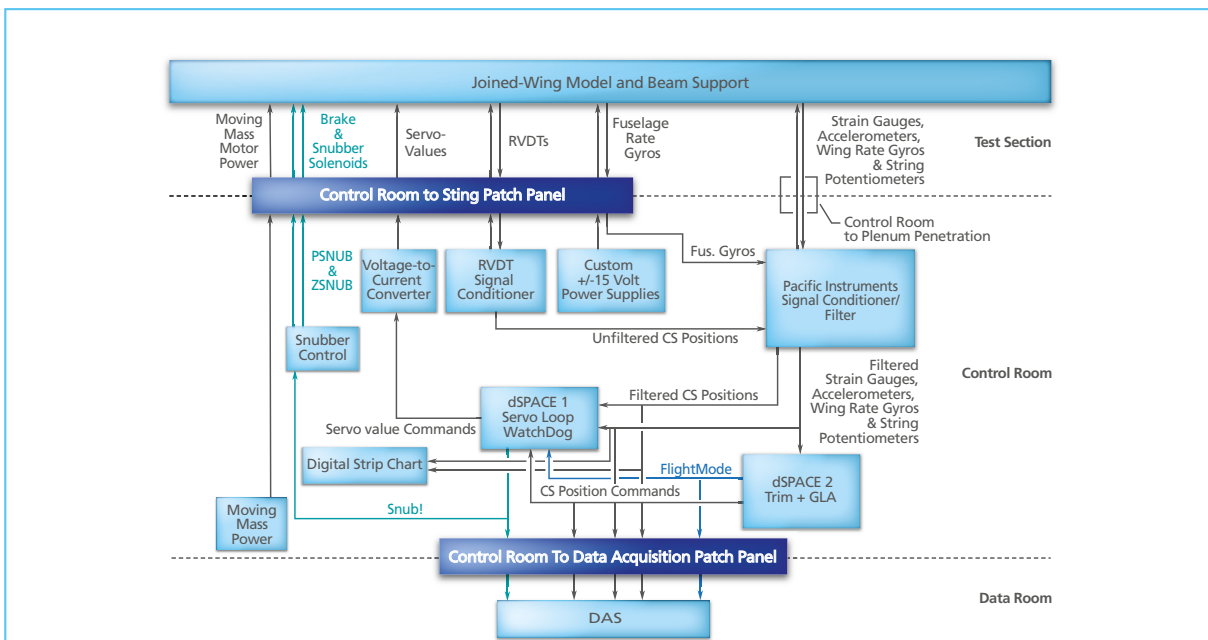

Figure 3: Joined-Wing SensorCraft in the NASA Langley Transonic Dynamics Tunnel.

sequence. An excitation signal could be added to various combinations of the control surface commands when conducting parameter identification testing. These commands were output as analog signals to dSPACE 1. The servo-control loops and the WatchDog system were implemented on dSPACE 1. The servo-loops were independent PID control loops equipped with output saturation blocks to prevent overdriving the actuators. The WatchDog system

monitored the model signals, and when a fault was detected, it would issue a "Snub!" command and transfer control to the emergency control law via the switch shown in figure 5. For the joined-wing tests, the emergency controller consisted simply of 0° control surface commands, but a closed-loop controller was used in the test described in reference 1. As shown in figure 5, the various systems communicated with each other via the status >>

Figure 4: Signal routing used in the joined-wing tests.



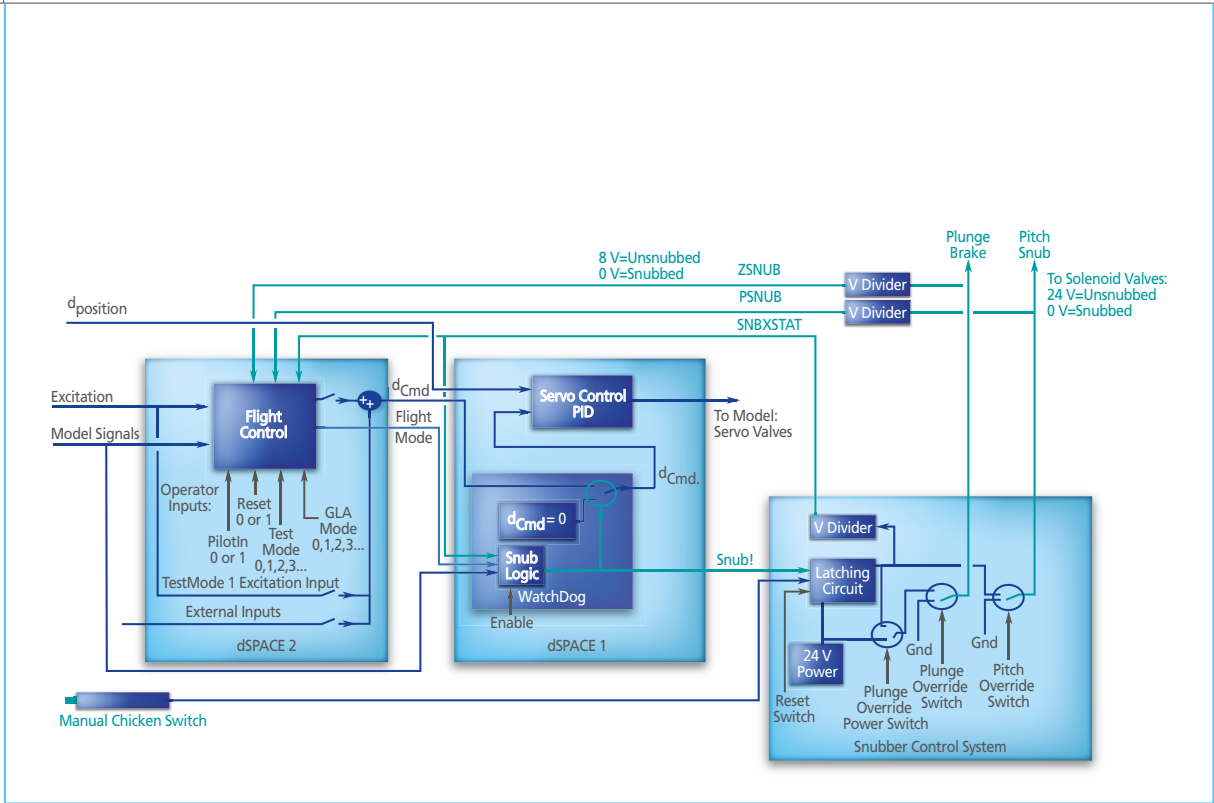

Figure 5: Block diagram of dSPACE systems and snubber control.

signals coming from the snubber control system to dSPACE 1, the FlightMode signal from dSPACE 2 to dSPACE 1, and the Snub! signal from dSPACE 1 to the snubber control system. These means of communication along with proper user inputs solved one of the key challenges of the joined-wing wind-

tunnel test, transitioning the model from being at the bottom of its range of vertical travel with plunge brake and pitch limiter engaged to flying freely at the center of the vertical travel range. The steps involved are detailed in reference 2 and beyond the scope of this article. Key features of the dSPACE 2 flight

control block are shown in figure 6. The primary components of this block are the trim and gust load alleviation (GLA) blocks, the Flight-Mode logic block, and the fault detection block. Model signals, snubber-related signals, operator inputs, and the relevant model signals are shown. The trim controller has two modes of operation: Theta hold and altitude (Z) hold. The exact mode of operation is determined by the user inputs and the model vertical position. Logic for ramping the vertical position set point from the lower stop to tunnel centerline is also contained in the trim control block. The operation of the GLA control block is controlled by the user input GLAMode. When GLAMode is set to 0, the GLA control block simply passes through the control surface commands. When this parameter is greater than 0, strain gauge feedback was used to generate GLA control surface commands that are added to the trim controller outputs. The trim controller was designed to launch, fly and land the model in the wind tunnel and to serve as the reference for GLA reduction. The trim control-

Figure 6: Block diagram of the flight control system.

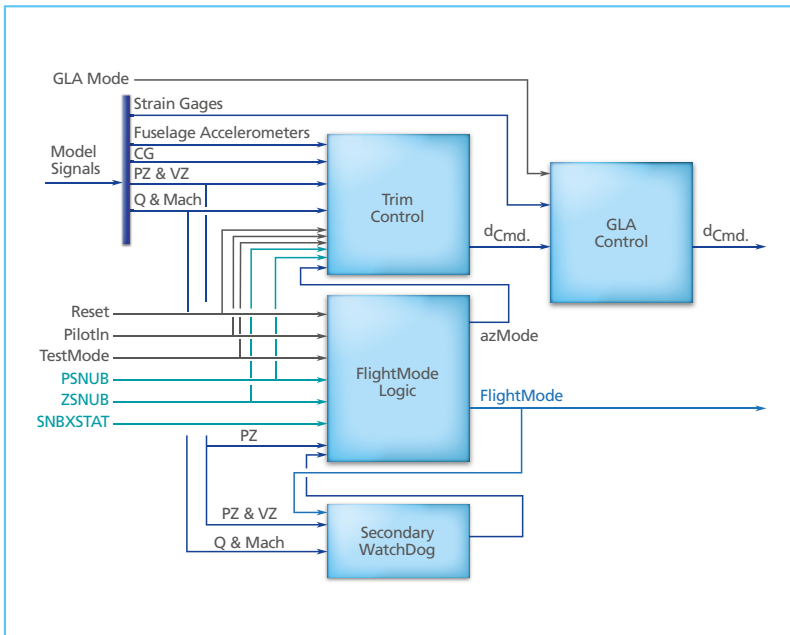

ler consisted of two main elements, a vertical (Z) loop and a pitch (θ) loop. The vertical loop consisted of a simple PID controller that generated an acceleration command. The pitch loop consisted of a PID plus acceleration feed-forward controller to generate an elevator surface command from the acceleration command. These two loops used gains that were scheduled based on the model's center of gravity. The single control surface command was passed through a third-order low pass filter to attenuate the response at higher frequencies.

dSPACE Systems

Each dSPACE Digital Control System (DCS) consists of a rack containing a host computer, a target system, a keyboard, a monitor, BNC patch panels for I/O, and an uninterruptible power source. The heart of the DCS is the target system that includes a dSPACE DS1006 control processor board utilizing a 2.6 GHz AMD Opteron™ processor connected to three dSPACE DS2002 Multi-Channel A/D Boards and one dSPACE DS2103 Multi-Channel D/A Board. The A/D boards each have 32 channels utilizing 16-bit quantization with an input range of ± 10 volts. The D/A board contains 32 channels

of 14 quantization bits designed for ± 10 volts and a settling time of 10 μ sec. The controller software is developed within the MATLAB®/Simulink® environment, then compiled and downloaded to the target processor via the dSPACE and MATLAB Real-Time Interface. An integral component of the dSPACE tools is the ControlDesk® application. ControlDesk provides the user interface to the target processor for the development and implementation of the GUI. The host computer runs the GUI and controls all communications between the processors. ■

David A. Coulson and Robert C. Scott, NASA

References

[1] Scott, R., Vetter, T., Penning, K., Coulson, D., and Heeg, J., "Aerosevoelastic Testing of Free Flying Wind-Tunnel Models Part 1: A Sidewall Supported Semispan Model Tested for Gust Load Alleviation and Flutter Suppression," NASA/TP-2013-218051, Oct. 2013.

[2] Scott, R., Castelluccio, M., Coulson, D., and Heeg, J., "Aerosevoelastic Testing of Free Flying Wind-Tunnel Models Part 2: A Centerline Supported Fullspan Model Test for Gust Load Alleviation," NASA/TP-2014-218170, Feb. 2014.

Results

Closed-loop wind tunnel tests were conducted over a period of approximately six weeks. Throughout testing, both the trim controller and the GLA control law were continually refined. The general process was to design, implement, test, and evaluate the trim and GLA controllers. This process was repeated multiple times during the testing period. As the testing progressed, improved testing procedures were developed that allowed better parameter identification data sets to be acquired. These data sets were used to further refine the analytical models, helping to improve the trim and GLA controller designs. Ultimately, trimmed flight at -10 percent static margin and a reduction of structural response of at least 50 percent were successfully demonstrated. The ability to customize and reconfigure the dSPACE systems, and their compatibility with the industry-standard MATLAB computing environment were key success factors in this wind tunnel test. This is exemplified by the fact that the control law development work was done by a team member located on the West Coast, while the TDT is located on the East Coast. Updated control systems could easily be delivered to the TDT as Simulink models, dropped into the existing framework, compiled, and be ready to run in a matter of minutes. Numerous control design iterations could thus be attempted, leading to a successful outcome.

David A. Coulson

Senior Research Engineer, Active Controls at the NASA TDT, Analytical Services & Materials, Inc., Hampton, VA, USA.



Robert C. Scott

Senior Aerospace Engineer, Aeroelasticity Branch, NASA Langley Research Center, Hampton, VA, USA.

