

Safe steering

Test system for validating the ECU of an electric power steering system at power level

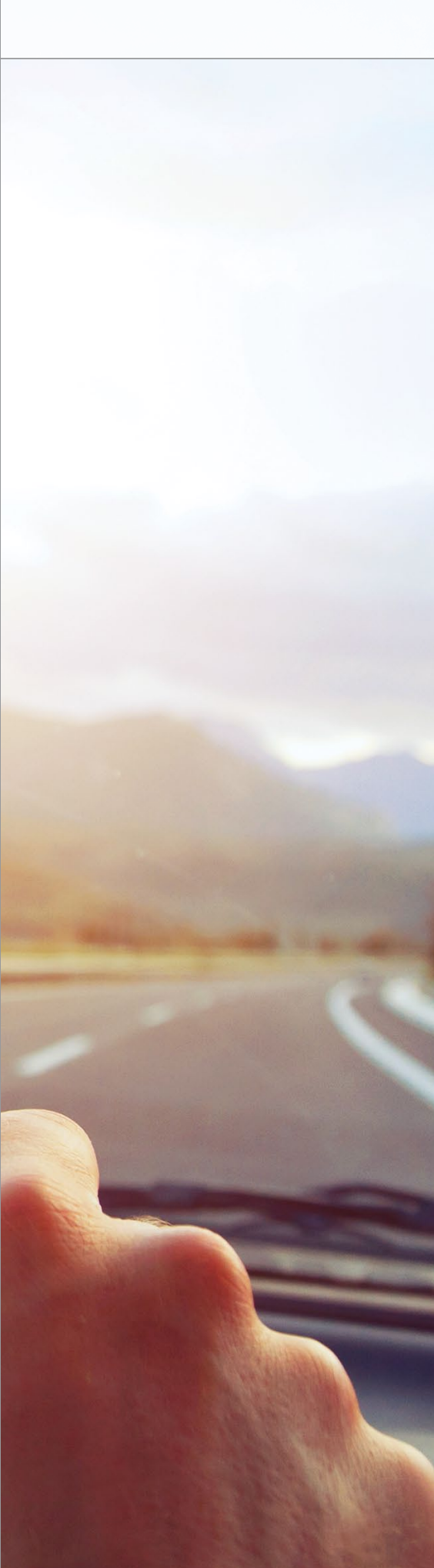

The electric power steering system is among the more safety-critical components of a vehicle. Its development must therefore meet stringent safety requirements. Japanese steering system manufacturer JTEKT has installed an ISO-26262-compliant process and a powerful test system for ECU development.

The test system for steering system ECUs with an operator workspace.



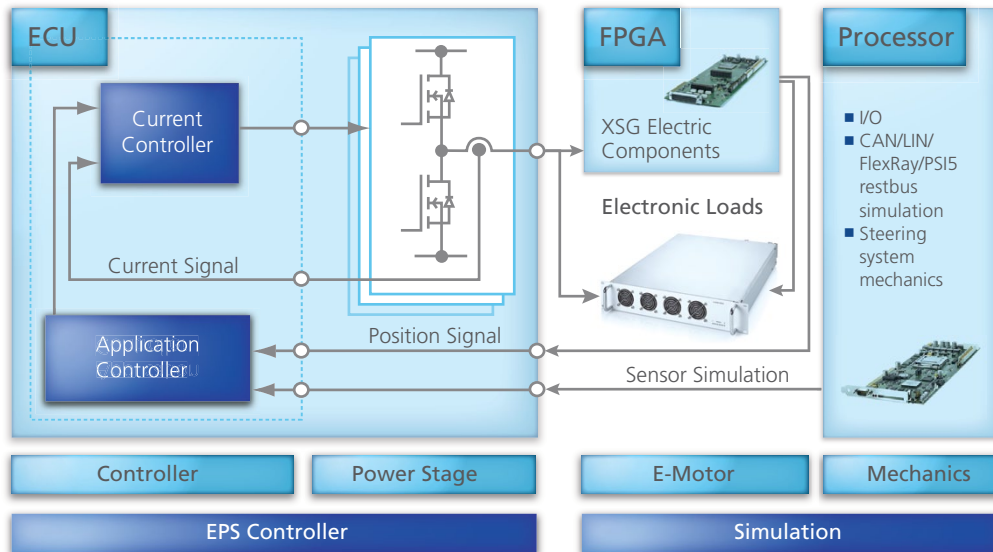

Load simulation components. The electric power steering (EPS) ECU is displayed on the left-hand side, the simulator including the processing units (FPGA, processor) plus the load module on the right-hand side.

Developing Safety-Critical Systems

JTEKT supplies automobile manufacturers with components such as steering systems and driveline components which have to meet strict safety requirements. This is particularly true for electric power steering (EPS) systems, which have to be developed according to

ISO 26262, the functional safety standard for road vehicles. It defines functional safety for automotive equipment applicable throughout the life cycle of all automotive electronic and electrical safety-related systems. A basic requirement for ISO-26262-compliant development is a complete, seamless development process that includes customer spec-

ifications, evaluation of interim results, and final verification.

Safety Requirements for Electric Power Steering Systems

At the beginning of a development project, a hazard analysis and risk evaluation is carried out. Applicable Automotive Safety Integrity Level (ASIL) requirements are identified and allocated. High-level functions of EPS systems are generally classified as ASIL D, the safety integrity level with the strictest requirements. There are more than 100 test requirements (items) for validating electronic control units (ECUs) according to ISO 26262. A clearly defined and structured work process ensuring complete testing is needed to efficiently meet these requirements in all customer projects. In particular, the requirements have to be traceable all the way to the test results.

The software development process for the electric power steering system. The test activities cover the areas of software unit testing and software integration testing.

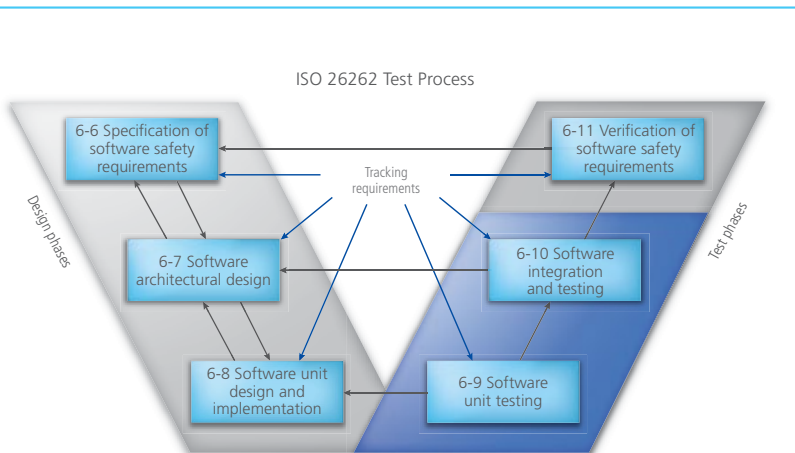

Solution: A Seamless Tool Chain

A seamless, transparent process requires an appropriate tool chain.

“In order to efficiently evaluate the controller of our electric power steering system according to ASIL D safety requirements, automatic test execution with a hardware-in-the-loop (HIL) simulator is indispensable.”

Hirozumi Eki, JTEKT

The core components of such a tool chain are requirements management and an ECU test system. For requirements management, JTEKT uses the IBM® software DOORS®. For ECU testing there are many established methods. Hardware-in-the-loop (HIL) simulation is used if automated, reproducible tests are required, and JTEKT uses associated simulators. To validate new families of electric power steering (EPS) systems, a HIL system setup tailored to the test task was to be designed.

Basic Requirements for the Test System

EPS ECU testing must be performed at power level, since the ECU cannot be modified to bypass the power stage. One of the main tasks of the HIL simulator is therefore the emulation of the electric motor. Motor currents have to be emulated precisely. The HIL simulator must therefore be able to exactly simulate fast processes and high currents. But the simulator also has to be flexible enough to simulate all automotive components that are relevant for ECU testing. All tests have to be automated, and requirements, test cases, and test results must be linked seamlessly and must be traceable.

Project-Specific Requirements

The detailed requirements for developing an electric power steering system comprise technical and organizational aspects:

- 1) Creating automated, ready-to-use test sequences for test engineers
- 2) Generating the required HIL signals for the ECU as specified in test sequences by the user
- 3) Measuring signals of the HIL simulator and the ECU, and adjusting parameters during the test sequences
- 4) Automatic evaluation of test results as status reports
- 5) Exporting test data (measuring data from (3), evaluation from (4)) for an external system
- 6) Generating motor simulation values (motor phase current, motor phase voltage at ECU power stage, and back EMF)

The Test System

After JTEKT studied and assessed different solutions on the market, dSPACE was commissioned to build a test system according to the requirements of the EPS project. The simulator consists of a processing unit (a quad-core DS1006 Processor Board) to simulate mechanical automotive components and various tasks at the restbus, as well as a fast FPGA (field programmable gate array) processing platform (DS5203)

to calculate the electric motor. The FPGA controls an electronic load system to emulate the electric motor. For this, the Electronic Load Module DS5381 is used. It has cascade-switching MOSFET power stages that reach switching frequencies of up to 3.2 MHz, thereby



dSPACE Simulator with the highly dynamic load emulator DS5381 (center).

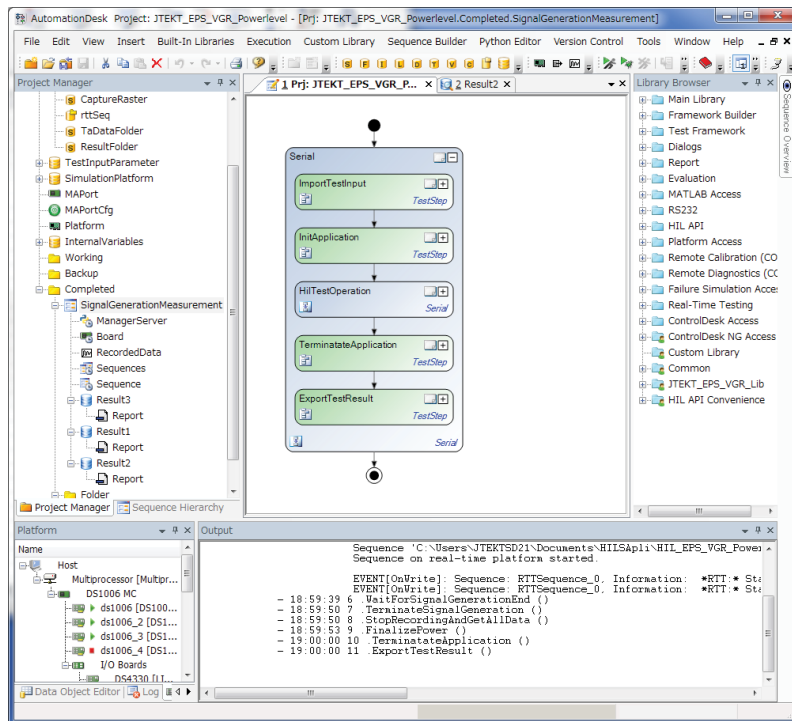

AutomationDesk defines, performs, and evaluates the automated tests.

ensuring a highly dynamic simulation of the electric motors. The simulator also has CAN/LIN/FlexRay interfaces to perform a restbus sim-

ulation of the connected systems. A peripheral sensor interface 5 (PSI5) board (DS2302) is available for the simulation of sensors of safety-criti-

Signal monitoring and display in ControlDesk Next Generation.

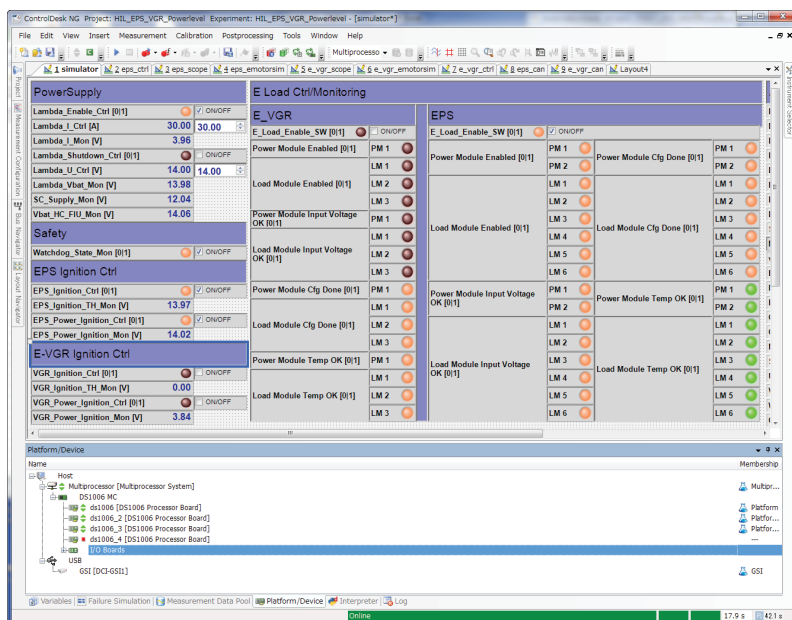

cal applications. A Failure Insertion Unit (FIU) equipped with high-current contactors is included to test ECU behavior in case of a short-circuit to another wire or ground. The electric motor simulation of the brushless DC (BLDC) motor of the EPS is performed on the FPGA using a BLDC motor model from the XSG Electric Components library. Models for the position encoder and the angular processing unit were implemented from the same library.

For signal evaluation, a software scope from the XSG Utils library is included on the FPGA. It can be used to record and display simulated signals (such as motor currents), or measured FPGA IO signals (such as phase voltages of the ECU power stage). The temporal resolution is in the range of nanoseconds.

Evaluation of the Test System

When the simulator was delivered, JTEKT was able to start operation immediately with the help of dSPACE Engineering. No changes or further settings were needed, saving the developers the entire preparation time. dSPACE even continues their support after the introduction of the HIL simulator.

The installed test system meets the requirements for a comprehensive EPS test. The evaluation of measured and simulated currents, torques, and position signals for different steering maneuvers delivers plausible results with the expected precision. The implemented FPGA processing platform in combination with the load unit ensures a stable closed-loop operation of the EPS ECU and the simulated electric motor with suitably fast sample times.

The combination of ControlDesk Next Generation with AutomationDesk makes the test system easy to use and automatable. In addition, the DCI-GS11 (generic

“We rely on the dSPACE DS5203 FPGA board and the XSG Electric Components library for the electric motor simulation of our steering systems. The achieved performance and simulation quality are best suited for our applications.”

Tetsuya Nozawa, JTEKT

serial interface) can read the ECU's RAM so the testers are well-informed about the processes in the EPS ECU and can perform diagnostics tasks if necessary. Last but not least, the requirements managed in DOORS can be traced throughout the entire tool chain.

Conclusion and Outlook

The dSPACE simulator and the integrated load have proven their worth in the development project. The EPS electronic control units for steering systems of different customer vehicles were successfully validated. Because the dSPACE product portfolio covers the entire V-cycle, the HIL tests can be coordinated with the results of tools for rapid control prototyping (MicroAutoBox) and production code generation (Target-Link). The simulator already contains a further FPGA board and an Electronic Load Module DS5381 for the

simulation of a future electric motor for an electronically controlled variable gear ratio steering (E-VGR). To emulate the mechanical load of the steering system, and therefore the mechanical load of the simulated electric motor, the ASM Vehicle Dynamics model will be used in the future. The test system is planned to not only validate ECUs but also to be used in the early development phases to test and optimize functions as early as possible. We cooperate closely with dSPACE to develop suitable solutions. In this context, the need for additional tools arises, mainly to manage data seamlessly and ensure compatibility across the entire tool chain. This could be solved with the data management tool SYNECT®. ■

*Hirozumi Eki,
Tetsuya Nozawa,
JTEKT*

Executive Summary

The Japanese steering system manufacturer JTEKT develops its electric power steering (EPS) systems in compliance with ISO 26262. To track requirements throughout all development stages, JTEKT relies on a seamless tool chain, in which the requirements management tool IBM DOORS, the dSPACE Simulator and the test automation tool dSPACE AutomationDesk play an essential role.

For a complete verification, JTEKT performs ECU tests with the hardware-in-the-loop (HIL) method at power level. For this purpose, the simulator must precisely emulate the electrical behavior of the electric motor. This objective is achieved with a fast FPGA (field programmable gate array) processing platform (DS5203) in combination with the Electronic Load Module (DS5381). They guarantee a highly dynamic emulation of high motor currents in real time. With the installed tool chain, JTEKT develops EPS systems in compliance with ISO 26262 and validates them successfully.

Hirozumi Eki

Hirozumi Eki is office manager of System Development Office 2 at JTEKT in Shinpukuji-cho, Okazaki, Japan.



Tetsuya Nozawa

Tetsuya Nozawa is development engineer at JTEKT in Shinpukuji-cho, Okazaki, Japan.

