

FPGA/Processor Combination Makes  
MicroAutoBox Even More Flexible

# Flexible Logic





With their powerful processors, rapid control prototyping (RCP) systems like the dSPACE MicroAutoBox II are ideal platforms for the model-based design and testing of new controller concepts. If applications have special I/O requirements, FPGAs come into play, supplementing the processors to boost performance and flexibility.

RCP systems like dSPACE MicroAutoBox II have an established position in the fast, model-based design and testing of new controller concepts. Controller models are implemented on this real-time hardware with push-button ease. Model parameters can be modified during run time, and signals can be easily captured. To give developers maximum freedom, the powerful processors in these systems can execute even extensive, processing-intensive controller models and I/O computation within extremely short cycle times. Even so, the I/O of some applications is so processing-intensive that it considerably reduces the capacity available for model computation. These are often applications with

extensive, fast, or parallel data preprocessing or postprocessing. In such cases, it makes sense to offload the I/O to a suitable device. With a hardware architecture that allows fast, parallel processing, FPGAs are ideal for this task. Another advantage is their adaptability and programmability, allowing new I/O functions to be added and existing ones to be modified. Concrete problems and their solutions are described in detail below with practical examples.

#### **Fast, Complex Data Preprocessing with FPGA**

If an application demands frequent, very fast I/O accesses and complex data preprocessing or analysis, such





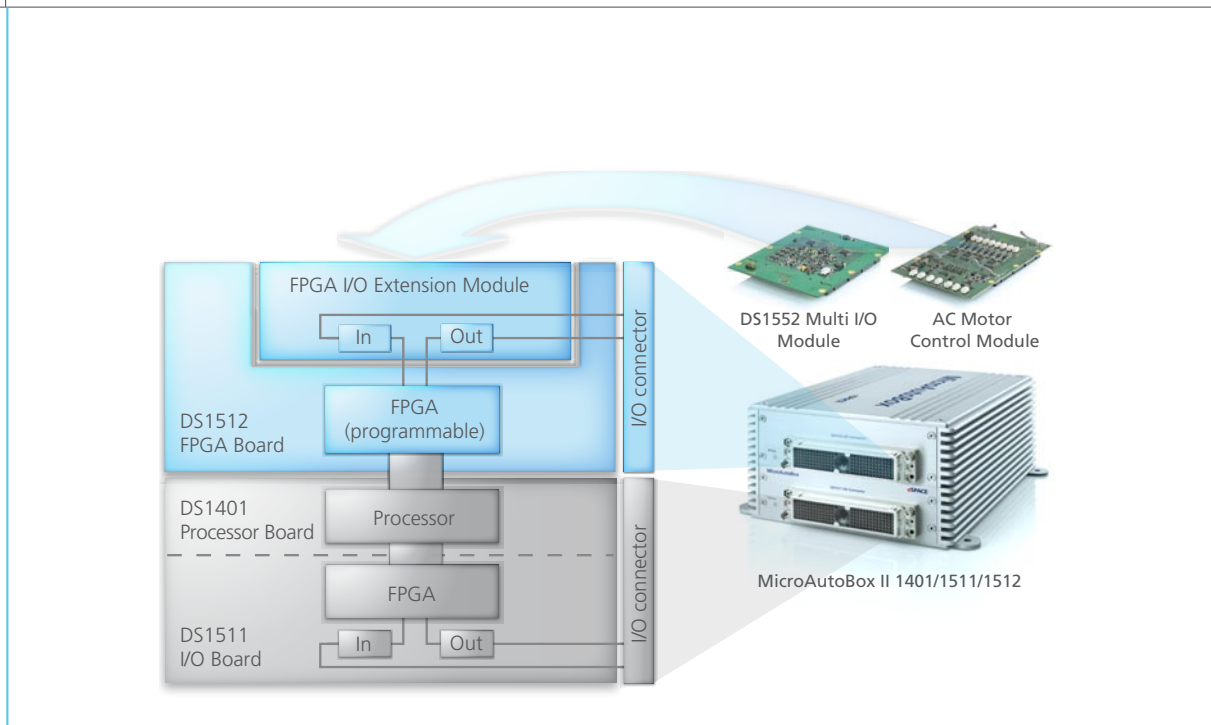

Figure 1: MicroAutoBox II variants 1401/1511/1512 with a user-programmable FPGA and slots for I/O modules.

as high-pass or low-pass filtering or fast Fourier transform of measurement values, it makes sense to run these tasks on upstream FPGAs. This reduces the load on the processor, freeing up valuable processing capacity for the actual controller computation. FPGAs can execute signal conditioning on different I/O channels and single functions in parallel and also completely independently of

one another. This speeds up computation and enables deterministic time behavior. The number of I/O channels can also be scaled without risking higher latencies. These same properties can be used to design fast, cascaded controllers with the inner control loop implemented on an FPGA, where cycle times of 10  $\mu$ s or sampling rates of 100 KHz and more are easily achieved.

#### Retrofitting I/O Functions Flexibly

Even though RCP systems support a large number of different I/O functions, it can still happen that a specific interface is not available for a particular application. There can be various reasons for this: The interface is a very special one, its specification is not publicly available, its necessity was not known at the time the RCP system was acquired, and so on. So the

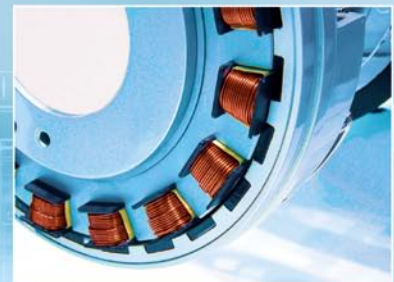

■ The FPGA's ability to perform fast, low-latency analysis of large data volumes independently of the processor enables the development of innovative combustion

processes to reduce vehicle fuel consumption and exhaust emissions. And because the FPGA can address numerous parallel control and measurement channels syn-

chronously, it is frequently used to control e-motors and converters in the implementation of electric and hybrid drive concepts.

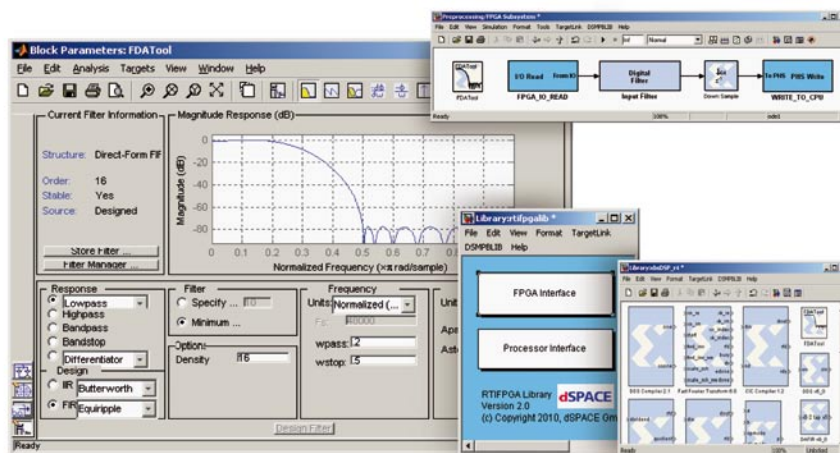

Figure 2: Model of a low-pass filter designed with the Xilinx® System Generator and implemented on the MicroAutoBox II by means of the dSPACE FPGA Programming Blockset – an example of model-based signal conditioning with FPGA support.

ability to add or modify I/O functions whenever necessary is extremely useful. FPGAs provide the required flexibility by allowing almost any digital circuit to be implemented, and unlike hard-wired interface components (such as ASICs), they can be changed at any time. For example, users have the freedom to implement different serial protocols to connect sensors from different vendors as required.

### Model-Based Development Simplifies FPGA Programming

FPGAs are traditionally programmed with text-based hardware description languages such as VHDL or Verilog. These provide access to all an FPGA's resources and allow functions to be optimized right down to the last detail. The down side is that users need specialist knowledge. If no one with sufficient VHDL skills and expe-

rience with FPGA technology and its specific properties is available, developers can nevertheless get off to a quick start with the aid of model-based development. The Xilinx® System Generator Blockset lets users model functions in MATLAB®/Simulink® and then implement them directly on the FPGA without any intermediate manual steps. Thus, they continue working in their familiar development



- The FPGA's architecture is perfect for fast, parallel data processing such as multi-channel filtering and frequency analysis.

For example, it is used in systems for high-quality active vibration damping or noise reduction, and for the health and usage monitor-

ing (HUMS) employed in mechanical engineering, railway technology, automobiles and aviation.

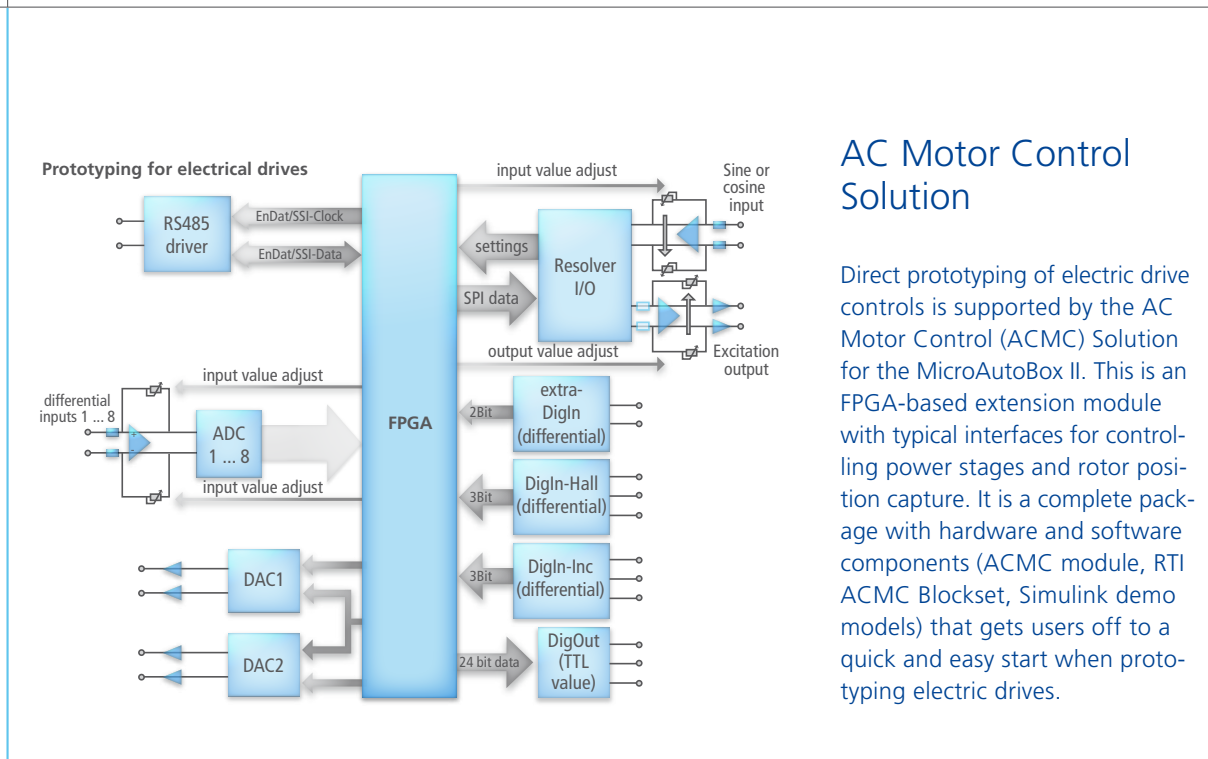

## AC Motor Control Solution

Direct prototyping of electric drive controls is supported by the AC Motor Control (ACMC) Solution for the MicroAutoBox II. This is an FPGA-based extension module with typical interfaces for controlling power stages and rotor position capture. It is a complete package with hardware and software components (ACMC module, RTI ACMC Blockset, Simulink demo models) that gets users off to a quick and easy start when prototyping electric drives.

environment and focus completely on function design. The blockset also gives developers convenient tools (such as one for designing digital filters) and enables them to integrate existing VHDL or Verilog source code into their models (Figure 2).

### MicroAutoBox II with FPGA

With all these advantages, it is clear

why dSPACE makes systematic use of FPGAs in our newest generation of MicroAutoBox II. The DS1401/-1511/1512 variant of dSPACE MicroAutoBox II gives developers the flexibility of user-programmable FPGAs (Figure 1). It has a Xilinx® Spartan-6-based FPGA board that can be freely programmed in VHDL or with the Xilinx® System Generator. To keep the latencies for I/O processing as

low as possible, the FPGA is connected to the processor via a fast parallel I/O bus and has direct interfaces to the I/O converters. For flexibility, the I/O converters themselves are on separate I/O modules that can be plugged onto the FPGA board and changed when the application changes. To support as many different applications as possible, dSPACE offers the DS1552 Multi-I/O Module,



- The FPGA is used to implement highly dynamic, cascaded controllers: for example, for very fast, very precise positioning tasks or for a control with particularly high

stiffness. There are applications in automation technology, medical engineering, robotics, and other fields. Because the FPGA can run the functions in parallel, even

very large-scale multi-axis systems can be controlled deterministically and with very low latencies.



## I/O Extension Modules for dSPACE MicroAutoBox II

	DS1552 Multi-I/O Module	AC Motor Control Solution	Customer- Specific Hard- ware Module
Model-based development for the CPU	✓	✓	🔧
Model based development for the FPGA	✓		🔧
VHDL-based development for the FPGA	✓		🔧

✓ = Available as a off-the-shelf product or solution  
 🔧 = Development on request by dSPACE Engineering Services, please inquire.

a universal I/O module with a large number of fast, powerful I/O converters and different serial interfaces. Users integrate the module into the Simulink model-based development environment with the dSPACE RTI

FPGA Programming Blockset (Figure 2). With all its versatility, the FPGA board can also provide the basis for application-specific I/O extensions. The DS1553 AC Motor Control Module (ACMC) is a tailor-made

solution for controlling electric motors. It has a large number of dedicated interfaces for the different types of rotor position capture (interfaces for Hall sensors, encoders, resolvers, EnDat, SSI and others) and for addressing the power stages. The module is supported by a predefined I/O blockset for Simulink with which users can implement the basic commutation methods (block and sinus) as well as PWM-synchronous measurement and control channels.

In cases where an application requires additional support for particular converters or I/O functions, customer-specific solutions can be developed. Thanks to the modular design, these are easily integrated into MicroAutoBox II. ■

On land, at sea, and in the air – with an FPGA module, the application scenarios of MicroAutoBox II are practically unlimited.



■ The FPGA's ability to generate and measure high-definition signals synchronously means it can also be used on test benches and in industrial automation. The fact that

higher order digital filters with narrow transition band can be directly implemented on the FPGA facilitates their use in noisy environments.

### In Brief

Every application has different requirements for an RCP system. MicroAutoBox II is dSPACE's extremely flexible, universal solution. An FPGA can be used to add or extend application-specific functions. Graphical programming is a simple, convenient way for users to adapt a development system to particular requirements. Equipped with an FPGA extension module, MicroAutoBox II is the ideal prototyping solution for a very broad range of applications.

Limited availability of the RTI FPGA Programming Blockset outside of Europe and Asia, please ask dSPACE.