

New Option for  
MicroAutoBox II Combines  
the Best of Two Worlds

# Twice the Punch

A new option for dSPACE's MicroAutoBox II prototyping system combines a real-time processor unit and a Windows/Linux-capable embedded PC, the MicroAutoBox Embedded PC. These form a single, powerful system that is ideal for the new trends in vehicle electronics development, and is also just as suitable for nonautomotive applications.



### The Demands of Advanced Driver Assistance Systems

The desire for greater road safety and less CO<sub>2</sub> emissions is a major force for innovation in the automotive industry. A prime example is the increase in development activities for advanced driver assistance systems in new generations of vehicles. Reliable recognition of the vehicle's environment and traffic

Figure 1: Everything in one box – the new MicroAutoBox II with integrated Embedded PC and Ethernet switch.



#### Real-Time Processor Unit

- Real-time operating system
- Real-time control
- Ideal for time-critical applications



#### PC-Based Platform

- Image processing
- Telematics
- Digital road maps
- User interfaces, e.g. touch screen
- ...

Windows®  
Linux

- Combined in a single system, from a single vendor
- Comprehensive I/O



Figure 2: All-rounder – dSPACE MicroAutoBox II with integrated Embedded PC and characteristic simple wiring and numerous switching options for autonomous operation.

situation is at the heart of such systems. Capturing data by video cameras and video processing are essential in this context, as well as covering greater ranges ahead of the vehicle. One approach to this is based on the predictive evaluation of digital road maps. Another relies on communication between the vehicle and its environment via WLAN or mobile communications.

#### Embedded PC for Telematics, Image Processing and Digital Map Data

In ECU function prototyping, tasks such as predictive road map evaluation, computing telematics software, and object recognition based on camera data typically run on an embedded PC. The actual control function – for adaptive cruise control (ACC), emergency brake assistants, etc. – runs on the real-time processor unit, which is networked with the ECUs in the vehicle via the bus system.

#### All-in-One Development Platform

MicroAutoBox II with the integrated Embedded PC is tailored to developing such systems. It contains a real-time processor unit and a Windows/Linux-capable embedded

implementation of the Ethernet interfaces were chosen specifically to ensure low communication latencies at a high data throughput. Simulink® blocksets are available to easily model the Ethernet interface on the embedded controller.

### The integrated solution for developing advanced driver assistance systems

PC within the same overall system. This gives users an IBM PowerPC with a real-time operating system and very low worst-case response times, plus an Intel® Atom™ processor (1.6 GHz), both with numerous interfaces. The Embedded PC also has 2 GB RAM and a 2.5" SATA hard disc (HDD) or solid state drive (SSD). An integrated Gigabit Ethernet switch lets the host PC address the real-time prototyping unit and the Embedded PC via the same Ethernet cable. The switch and the

#### Complete, Compact System for In-Vehicle Use

The new extended MicroAutoBox II is perfect for in-vehicle use: It has a compact, robust design, is very simple to wire, and its real-time prototyping unit and Embedded PC can be switched on and off synchronously. For example, the entire passively cooled system can be remote-controlled via the vehicle's ignition switch. Alternatively, the individual units can also be powered up and shut down separately. The input

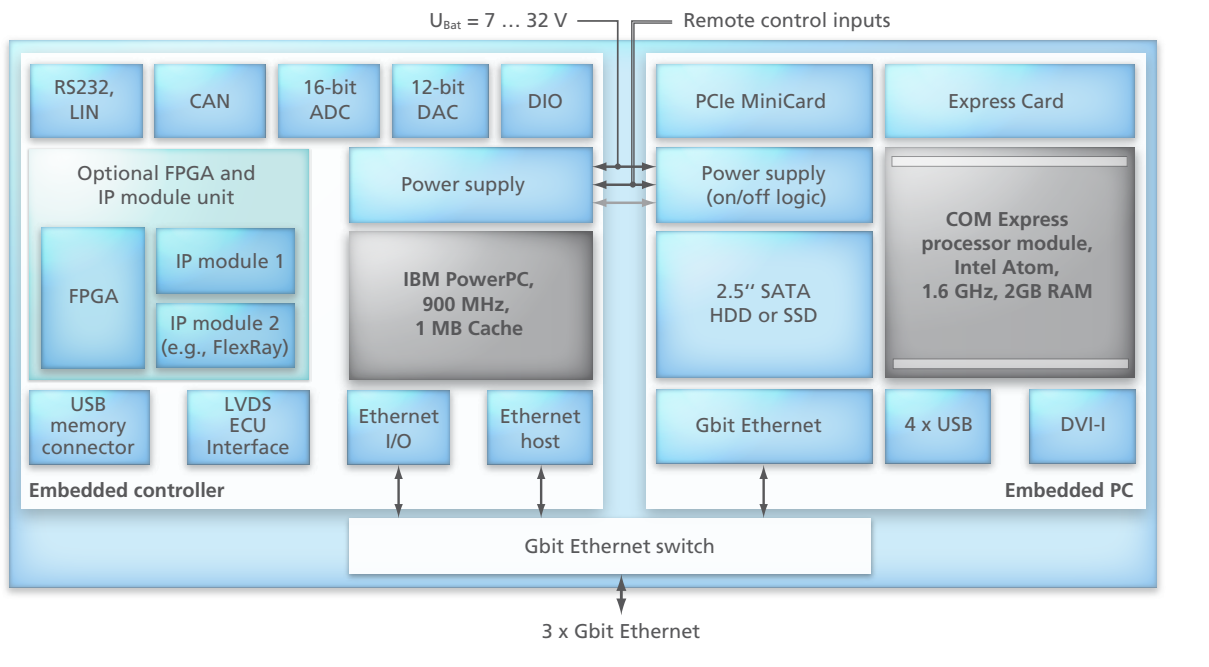

Figure 3: Block diagram of MicroAutoBox II with embedded controller and Embedded PC.

voltage range of 7 to 32 VDC, the sleep-mode current consumption of under 5 mA, and the overvoltage protection of the Embedded PC are all designed for permanent installation in a vehicle.

The possible uses of MicroAutoBox II are not restricted to the automotive field. It is just as helpful in fields such as industrial automation, robotics, medical engineering and aviation technology. Its applications are practically unlimited.

#### Numerous Interfaces and Flexible Extension Options

The new MicroAutoBox Embedded PC is modular in concept, so other embedded PC processors can be used as alternatives to the Intel Atom processor. The front panel of the Embedded PC provides three Gigabit Ethernet connectors, four USB 2.0 interfaces and a DVI-I output for transmitting video data. To give an example, touch screens can be connected to the overall system. The interfaces enable applications

where it is neither desirable nor possible to take a notebook on a vehicle test, like on a motorbike. MicroAutoBox II with Embedded PC also has an internal PCIe MiniCard slot and an Express Card slot for integrating WLAN, mobile communications or FireWire. ■

## Profile

Compact rapid prototyping system for real-time and PC applications

- Embedded controller for model-based function development
- Embedded PC for Windows/Linux-based applications
- Remote control options for switching individual units on/off
- Complete compact, robust system
- Fan-free operation

