

dSPACE Release

# New Features and Migration

Release 2020-A – May 2020

## How to Contact dSPACE

Mail:	dSPACE GmbH Rathenaustraße 26 33102 Paderborn Germany
Tel.:	+49 5251 1638-0
Fax:	+49 5251 16198-0
E-mail:	<a href="mailto:info@dspace.de">info@dspace.de</a>
Web:	<a href="http://www.dspace.com">http://www.dspace.com</a>

## How to Contact dSPACE Support

If you encounter a problem when using dSPACE products, contact your local dSPACE representative:

- Local dSPACE companies and distributors: <http://www.dspace.com/go/locations>
- For countries not listed, contact dSPACE GmbH in Paderborn, Germany.  
Tel.: +49 5251 1638-941 or e-mail: [support@dspace.de](mailto:support@dspace.de)

You can also use the support request form:

<http://www.dspace.com/go/supportrequest>. If you are logged on to mydSPACE, you are automatically identified and do not need to add your contact details manually.

If possible, always provide the serial number of the hardware, the relevant dSPACE License ID, or the serial number of the CmContainer in your support request.

## Software Updates and Patches

dSPACE strongly recommends that you download and install the most recent patches for your current dSPACE installation. Visit <http://www.dspace.com/go/patches> for software updates and patches.

## Important Notice

This publication contains proprietary information that is protected by copyright. All rights are reserved. The publication may be printed for personal or internal use provided all the proprietary markings are retained on all printed copies. In all other cases, the publication must not be copied, photocopied, reproduced, translated, or reduced to any electronic medium or machine-readable form, in whole or in part, without the prior written consent of dSPACE GmbH.

© 2000 - 2020 by:  
dSPACE GmbH  
Rathenaustraße 26  
33102 Paderborn  
Germany

This publication and the contents hereof are subject to change without notice.

AUTERA, ConfigurationDesk, ControlDesk, MicroAutoBox, MicroLabBox, SCALEXIO, SYNECT, SystemDesk, TargetLink and VEOS are registered trademarks of dSPACE GmbH in the United States or other countries, or both. Other brand names or product names are trademarks or registered trademarks of their respective companies or organizations.

# Contents

About This Document	9
Overview of dSPACE Release 2020-A	11
General Enhancements and Changes	11
New Features of dSPACE Help	13
Discontinuations	14
Product Version Overview	16
New Key Product Features	18
Aspects of Migrating from Previous Releases	25
Migrating to dSPACE Release 2020-A	25
AutomationDesk	27
New Features of AutomationDesk 6.3	27
Migrating to AutomationDesk 6.3	28
Automotive Simulation Models (ASM)	31
All ASM Products	32
Migrating All ASM Blocksets	32
ASM Base InCylinder	33
Migrating to ASM Base InCylinder Blockset 2.6.1	33
ASM Diesel Engine	34
New Features of ASM Diesel Engine Blockset 2.7.1	34
Changes in the ASM Diesel Engine Demo Model	34
Migrating to ASM Diesel Engine Blockset 2.7.1	35
ASM Diesel Exhaust	37
Migrating to ASM Diesel Exhaust Blockset 2.1.10	37
ASM Diesel InCylinder	38
Migrating to ASM Diesel InCylinder Blockset 2.7.2	38
ASM Drivetrain Basic	39
Migrating to ASM Drivetrain Basic Blockset 5.3.2	39

ASM Electric Components.....	40
New Features of ASM Electric Components Blockset 3.10.....	40
Changes in the ASM Electric Components Demo Model.....	40
Migrating to ASM Electric Components Blockset 3.10.....	40
ASM Environment.....	42
New Features of ASM Environment Blockset 4.12.....	42
Migrating to ASM Environment Blockset 4.12.....	42
ASM Gasoline Engine Basic.....	44
Changes in the ASM Engine Gasoline Basic Demo Model.....	44
Migrating to ASM Gasoline Engine Basic Blockset 2.2.5.....	44
ASM Gasoline Engine.....	45
New Features of ASM Gasoline Engine Blockset 4.1.1.....	45
Changes in the ASM Engine Gasoline Demo Model.....	45
Migrating to ASM Gasoline Engine Blockset 4.1.1.....	46
ASM Gasoline InCylinder.....	48
Migrating to ASM Gasoline InCylinder Blockset 2.7.2.....	48
ASM Traffic.....	49
New Features of ASM Traffic Blockset 4.1.....	49
Changes in the ASM Traffic Demo Model.....	50
Migrating to ASM Traffic Blockset 4.1.....	50
ASM Utils.....	51
New Features of ASM Utils 4.1.3.....	51
ASM Vehicle Dynamics.....	52
New Features of ASM Vehicle Dynamics Blockset 4.1.3.....	52
Migrating to ASM Vehicle Dynamics Blockset 4.1.3.....	52
<b>Bus Manager (Stand-Alone)</b> .....	<b>53</b>
New Features of the Bus Manager (Stand-Alone) 6.5.....	53
<b>ConfigurationDesk 6.5 - Implementation Version</b> .....	<b>57</b>
New Features of ConfigurationDesk.....	57
New Features Concerning I/O Functionality and Hardware Support.....	60
New Features of the Bus Manager in ConfigurationDesk.....	63
Supported Container File Versions.....	65
Migrating to ConfigurationDesk 6.5.....	67

<b>ControlDesk</b>	<b>69</b>
New Features of ControlDesk 7.2.....	70
New Features of Platform Management and Platforms/Devices (ControlDesk 7.2).....	70
New Layouting Features (ControlDesk 7.2).....	71
New Instrument Features (ControlDesk 7.2).....	72
New Measurement and Recording Features (ControlDesk 7.2).....	73
New Bus Navigator Features (ControlDesk 7.2).....	74
Additional Enhancements and Changes with ControlDesk (ControlDesk 7.2).....	76
Migrating to ControlDesk 7.2.....	77
Discontinuations in ControlDesk.....	77
Migrating to ControlDesk 7.2.....	78
<b>DCI Configuration Tool</b>	<b>81</b>
New Features of the DCI Configuration Tool 3.12.....	81
Migrating to DCI Configuration Tool 3.12.....	82
<b>dSPACE ECU Flash Programming Tool</b>	<b>83</b>
New Features of the dSPACE ECU Flash Programming Tool 2.7.....	83
Discontinuations in the dSPACE ECU Flash Programming Tool.....	83
<b>dSPACE FlexRay Configuration Package</b>	<b>85</b>
New Features of dSPACE FlexRay Configuration Package 4.5.....	85
Migrating to dSPACE FlexRay Configuration Package 4.5.....	86
<b>dSPACE Installation Manager</b>	<b>87</b>
New Features of dSPACE Installation Manager 5.5.....	87
Migrating to dSPACE Installation Manager 5.5.....	87
<b>dSPACE XIL API .NET</b>	<b>89</b>
New Features of dSPACE XIL API .NET 2020-A.....	89
Migrating to dSPACE XIL API .NET 2020-A.....	89

<b>ECU Interface Manager</b>	<b>91</b>
New Features of ECU Interface Manager 2.7.....	91
Compatibility of ECU Interface Manager 2.7.....	92
Migrating to ECU Interface Manager 2.7.....	92
<b>Firmware Manager</b>	<b>95</b>
New Features of Firmware Manager 3.1.....	95
<b>MicroAutoBox III Firmware</b>	<b>97</b>
New Features of the MicroAutoBox III Firmware.....	97
<b>ModelDesk</b>	<b>99</b>
New Features of ModelDesk 5.3.....	99
Migration to ModelDesk 5.3.....	100
<b>Model Interface Package for Simulink</b>	<b>101</b>
New Features of the Model Interface Package for Simulink 4.3.....	101
Migrating to the Model Interface Package for Simulink 4.3.....	102
<b>MotionDesk</b>	<b>103</b>
New Features of MotionDesk 4.6.....	104
MotionDesk Features (MotionDesk 4.6).....	104
Camera and Fish-Eye Sensor Features (MotionDesk 4.6).....	106
Migrating to MotionDesk 4.6.....	107
<b>Real-Time Testing</b>	<b>109</b>
New Features of Real-Time Testing 4.3.....	109
Migrating to Real-Time Testing 4.3.....	109
<b>RTI/RTI-MP and RTLib</b>	<b>111</b>
New Features of RTI/RTI-MP and RTLib.....	111
Migration Aspects of RTI/RTI-MP and RTLib.....	112

<b>RTI Bypass Blockset</b>	<b>115</b>
New Features of the RTI Bypass Blockset 3.14.....	115
Migrating to RTI Bypass Blockset 3.14.....	116
<b>RTI CAN MultiMessage Blockset</b>	<b>119</b>
New Features of the RTI CAN MultiMessage Blockset 5.4.....	119
Migrating to RTI CAN MultiMessage Blockset 5.4.....	119
<b>RTI FPGA Programming Blockset</b>	<b>123</b>
New Features of the RTI FPGA Programming Blockset 3.9.....	123
Migrating to the RTI FPGA Programming Blockset 3.9.....	126
<b>RTI LIN MultiMessage Blockset</b>	<b>129</b>
New Features of the RTI LIN MultiMessage Blockset 3.4.....	129
Migrating to RTI LIN MultiMessage Blockset 3.4.....	129
<b>RTI Synchronized Time Base Manager Blockset</b>	<b>131</b>
Migrating to the RTI Synchronized Time Base Manager Blockset 1.4.....	131
<b>SCALEXIO Firmware</b>	<b>133</b>
New Features of the SCALEXIO Firmware 4.6.....	133
<b>Sensor Simulation</b>	<b>135</b>
New Features of Sensor Simulation 1.3.....	135
<b>SYNECT</b>	<b>137</b>
New Features of SYNECT 2.9.....	138
New General Features of SYNECT.....	138
OData Support.....	139
New Features of Test Management.....	143
New Features of Workflow Management.....	144
Migrating to SYNECT 2.9.....	147
Migrating Databases.....	147

Migrating from SYNECT 2.8.....	147
Data Model Changes From SYNECT 2.8 to SYNECT 2.9.....	149
<b>VEOS</b>	<b>151</b>
New Features of VEOS 5.0.....	151
Compatibility of VEOS 5.0.....	152
Migrating to VEOS 5.0.....	155
<b>Compatibility Information</b>	<b>157</b>
Supported MATLAB Releases.....	157
Operating System.....	158
Using dSPACE Software on Virtual Machines (VMs).....	160
Run-Time Compatibility of dSPACE Software.....	164
Limitations for Using Windows Features.....	165
<b>Index</b>	<b>169</b>



# About This Document

## Content









This document informs you about the new features of all the dSPACE software products in Release 2020-A. It also gives you an overview of software products with no or minor changes. There are instructions on migrating from earlier dSPACE Releases, especially from earlier product versions, if required.

## Printed document

A printed copy of this document is available on demand. You can order it free of charge by using the following link:  
<http://www.dspace.com/go/requestreleasematerial>.

## Symbols

dSPACE user documentation uses the following symbols:

Symbol	Description
	Indicates a hazardous situation that, if not avoided, will result in death or serious injury.
	Indicates a hazardous situation that, if not avoided, could result in death or serious injury.
	Indicates a hazardous situation that, if not avoided, could result in minor or moderate injury.
	Indicates a hazard that, if not avoided, could result in property damage.
	Indicates important information that you should take into account to avoid malfunctions.
	Indicates tips that can make your work easier.
	Indicates a link that refers to a definition in the glossary, which you can find at the end of the document unless stated otherwise.
	Precedes the document title in a link that refers to another document.

## Naming conventions

dSPACE user documentation uses the following naming conventions:

**%name%** Names enclosed in percent signs refer to environment variables for file and path names.

**< >** Angle brackets contain wildcard characters or placeholders for variable file and path names, etc.

---

## Special folders

Some software products use the following special folders:

**Common Program Data folder** A standard folder for application-specific configuration data that is used by all users.

`%PROGRAMDATA%\dSPACE\`

or

`%PROGRAMDATA%\dSPACE\`

**Documents folder** A standard folder for user-specific documents.

`%USERPROFILE%\Documents\dSPACE\`

**Local Program Data folder** A standard folder for application-specific configuration data that is used by the current, non-roaming user.

`%USERPROFILE%\AppData\Local\dSPACE\`

---

## Accessing dSPACE Help and PDF Files

After you install and decrypt dSPACE software, the documentation for the installed products is available in dSPACE Help and as Adobe® PDF files.

**dSPACE Help (local)** You can open your local installation of dSPACE Help:

- On its home page via Windows Start Menu
- On specific content using context-sensitive help via **F1**

**dSPACE Help (Web)** You can access the Web version of dSPACE Help at [www.dspace.com](http://www.dspace.com).

To access the Web version, you must have a *mydSPACE* account.

**PDF files** You can access PDF files via the  icon in dSPACE Help. The PDF opens on the first page.

# Overview of dSPACE Release 2020-A

---

**Introduction** Gives you an overview of the new key features in Release 2020-A and information about unchanged products.

---

**Where to go from here**

**Information in this section**

General Enhancements and Changes.....	11
New Features of dSPACE Help.....	13
Discontinuations.....	14
Product Version Overview.....	16
New Key Product Features.....	18

## General Enhancements and Changes

---

**Introduction** The following new features and changes concern several dSPACE products.

---

**Support of new dSPACE hardware**

dSPACE Release 2020-A introduces new dSPACE hardware:

- MicroAutoBox III Embedded PC

A MicroAutoBox III Embedded PC is a compact PC system that can be used for developing and validating advanced driver assistance, infotainment or telematics systems, or to execute ControlDesk directly on the MicroAutoBox III system.

For more information, refer to [Embedded PC Features](#) (📖 [MicroAutoBox III Embedded PC Hardware Installation and Configuration](#)).

**Python distribution**

The libraries and components used with Python 3.6 and distributed on dSPACE DVDs have changed as shown in the following table.

Package	Release 2019-B	Release 2020-A
comtypes	1.1.7	1.1.7
Core	3.6.8	3.6.8
cycler	0.10.0	0.10.0
kiwisolver	1.1.0	1.1.0
matplotlib	3.1.0	3.1.1
numpy	1.16.4	1.17.3
pillow	6.0.0	6.2.1
pip	19.1.1	19.3.1
yparsing	2.4.0	2.4.2
pypubsub	4.0.3	4.0.3
Python-dateutil	2.8.0	2.8.0
pythonnet	2.4.1	2.4.1
pytz	2019.1	2019.3
pywin32	224.10	225.10
six	1.12.0	1.12.0
wxPython	4.0.6	4.0.7
future	-	0.18.2
grpcio_tools	-	1.25.0
grpcio	-	1.25.0
protobuf	-	3.10.0
pyglet	-	1.4.6
scipy	-	1.3.1
Yapsy	-	1.12.2

**Using dSPACE software on virtual machines (VM)**

As of dSPACE Release 2019-A, you can operate several dSPACE products on virtual machines. For more information, refer to [Using dSPACE Software on Virtual Machines \(VMs\)](#) on page 160.

**Legacy licensing using CodeMeter licenses simplifies installation and use of dSPACE releases earlier than 2017-B**

If you own a software product from dSPACE Release 2017-B or later and you want to install and use a version of this product from a dSPACE Release earlier than 2017-B, you must have legacy license files and a CodeMeter CmContainer with activated licenses. Until now, you had to contact dSPACE and provide specific information before dSPACE sent you the license files.

As of October 2019, you can use dSPACE Installation Manager 5.4 to download license files specifically prepared on the basis of the licenses you purchased. Legacy licensing using CodeMeter licenses maps former product versions to an

available license so that you can install and use products from dSPACE Release 7.4 (2012-B) up to dSPACE Release 2017-A.

Refer to [Legacy Licensing Using CodeMeter Licenses](#) ([Working with CodeMeter Licensing Technology](#)).

### RCP and HIL software: C/C++ compilers for building MATLAB MEX files

RCP and HIL software (such as RTI CAN MultiMessage Blockset, RTI LIN MultiMessage Blockset, or Automotive Simulation Models) now supports the following C/C++ compilers for building MATLAB MEX files:

- MinGW (GNU Compiler Collection (GCC 6.3.0))
- Microsoft Visual Studio 2017 Professional

## New Features of dSPACE Help

### Enhanced navigation

As of Release 2020-A, dSPACE Help provides enhanced navigation with a topic navigation and related topics on the right-hand side.

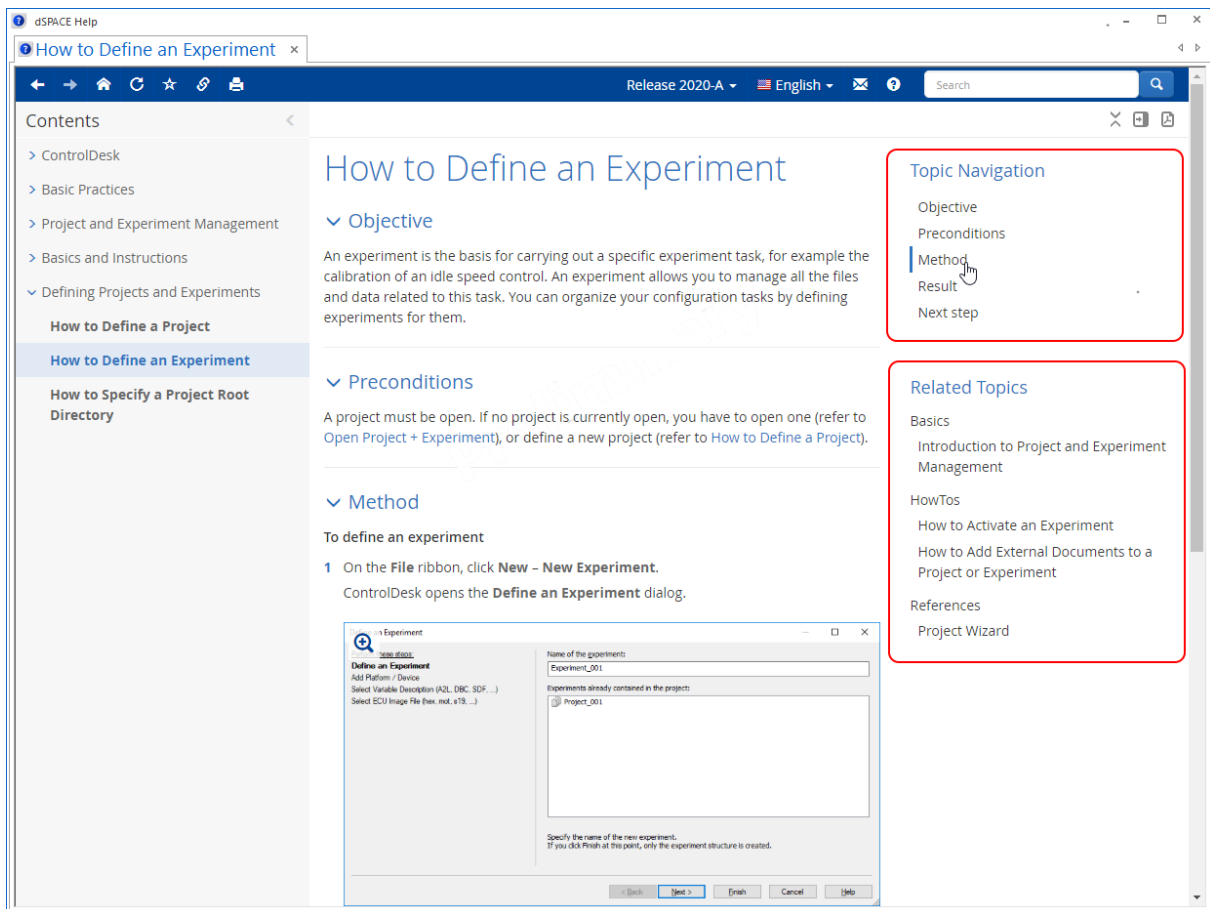

**Topic Navigation** The new Topic Navigation is located at the top right of the user interface and lets you navigate within the selected topic. As you scroll through the topic, the displayed topic section is highlighted.

**Related Topics** If a topic contains links to related topics, they are displayed below the Topic Navigation.

**Visibility of navigation elements** Contents, Topic Navigation, and Related Topics remain visible, even if you scroll through the topic content. You no longer have to scroll back to access the navigation elements.

---

### Using dSPACE Help

For a detailed description of and instructions for dSPACE Help features, click  in dSPACE Help.

## Discontinuations

---

### Introduction

The following discontinuations for software and hardware are relevant to the current Release or are planned for future Releases.

For more end-of-life announcements, refer to <http://www.dspace.com/go/discontinuation>.

---

### Discontinuation of dSPACE hardware

With Release 2020-A, software support is discontinued for the following products:

- DS1005 PPC Board  
For new projects, we recommend that you use the dSPACE DS1007 PPC Processor Board.
- MicroAutoBox II variants with the DS1512 I/O Board  
For new projects, we recommend that you use the MicroAutoBox II or MicroAutoBox III variants with DS1514 I/O Board.
- DCI-CAN1  
For new projects, we recommend that you use the DCI-CAN2 or DCI-CAN/LIN1.
- DCI-GSI1  
For new projects, we recommend that you use the DCI-GSI2.

---

### Discontinuation of software support

**Discontinuation of dSPACE CAN API 1.0** As of dSPACE Release 2020-A, dSPACE CAN API 1.0 is no longer supported. Use dSPACE CAN API 2.0 instead. It is the successor of dSPACE CAN API 1.0, includes all previous features, and additionally supports CAN FD.

**Discontinuation of Windows 7** Because the official Microsoft support for Windows 7 ended in January 2020, dSPACE discontinues the support for Windows 7 SP1 as operating system with dSPACE Release 2020-A.

---

**Planned discontinuation of dSPACE hardware**

**MicroAutoBox Embedded SPU** As of Release 2020-B, software support will be discontinued for the MicroAutoBox Embedded SPU, which was discontinued in previous Releases.

For new projects, we recommend that you use the dSPACE AUTERA AutoBox.

**DS541 DPMEM POD for MPC55xx** As of Release 2020-B, software support will be discontinued for the DS541 DPMEM POD for MPC55xx, which was discontinued in previous Releases.

For new projects, we recommend that you use the dSPACE DCI-GSI2.

**PHS-Bus Hardware** As of December 2021, the hardware components for PHS-bus-based systems, such as the DS1006 Processor Board, the DS1007 PPC Processor Board, and all the PHS-bus I/O boards, will be discontinued. This is also relevant to the dSPACE Simulator Mid-Size and the dSPACE Simulator EcoLine. New Releases of dSPACE software will continue to support the PHS-bus hardware components until the end of 2023.

For new projects, we recommend that you use SCALEXIO as a modular real-time system.

---

**Planned software support discontinuation**

**Discontinuation of .NET 2.0 APIs** With dSPACE Release 2020-B, dSPACE discontinues the support for client programs and libraries built with .NET Runtime 2.0. This applies to any C#-based programs using the provided interfaces (APIs) for COM automation and for the Installation Manager. Applications using these interfaces have to use at least .NET Runtime 4.0.

**SCALEXIO firmware operating system change in Release 2020-B** To speed-up the development of new features and to provide an improved real-time execution for SCALEXIO, dSPACE changes the basic operating system of the SCALEXIO firmware in Release 2020-B to Linux™.

This will affect real-time applications, model containers (i.e. BSC, FMU, SIC, V-ECU), s-functions and custom I/O-functions that contain binary libraries built for dSPACE Release 2020-A and older. All real-time applications, precompiled model containers and binary libraries used for SCALEXIO are required to be (re)-built from source code based on dSPACE Release 2020-B. More information for supporting the migration will be provided with Release 2020-A and 2020-B.

## Product Version Overview

### Product versions

The following table is an extract from product version histories showing the product versions of the current Release and of the three preceding Releases. If a product has new features, there is a link to the brief description in this document.

Product	dSPACE Release			
	2018-B	2019-A	2019-B	2020-A
AutomationDesk	6.0	6.1	6.2	6.3 Refer to <a href="#">AutomationDesk</a> on page 27.
Automotive Simulation Models	9.2	9.3	9.4	9.5 Refer to <a href="#">Automotive Simulation Models (ASM)</a> on page 31.
Bus Manager (stand-alone)	6.2	6.3	6.4	6.5 Refer to <a href="#">Bus Manager (Stand-Alone)</a> on page 53.
ConfigurationDesk - Configuration Version	6.2	6.3	6.4	6.5
ConfigurationDesk - Implementation Version	6.2	6.3	6.4	6.5 Refer to <a href="#">ConfigurationDesk 6.5 - Implementation Version</a> on page 57.
Container Manager	5.1	5.1	5.1	5.1
ControlDesk	6.4	7.0	7.1	7.2 Refer to <a href="#">ControlDesk</a> on page 69.
DCI Configuration Tool	3.10	3.11	3.11	3.12 Refer to <a href="#">DCI Configuration Tool</a> on page 81.
dSPACE CAN API Package	4.0.1	4.0.2	4.0.3	4.0.4
dSPACE ECU Flash Programming Tool	2.5	2.6	2.6	2.7 Refer to <a href="#">dSPACE ECU Flash Programming Tool</a> on page 83.
dSPACE FlexRay Configuration Package	4.2	4.3	4.4	4.5 Refer to <a href="#">dSPACE FlexRay Configuration Package</a> on page 85.
dSPACE Python Extensions	3.0	3.1	3.2	3.3
dSPACE XIL API .NET	2018-B	2019-A	2019-B	2020-A Refer to <a href="#">dSPACE XIL API .NET</a> on page 89.
ECU Interface Manager	2.4	2.5	2.6	2.7 Refer to <a href="#">ECU Interface Manager</a> on page 91.



Product	dSPACE Release			
	2018-B	2019-A	2019-B	2020-A
Firmware Manager	2.6	2.7	3.0	3.1 Refer to <a href="#">Firmware Manager</a> on page 95.
Model Compare	2.9	2.9	3.0	3.0
ModelDesk	5.0	5.1	5.2	5.3 Refer to <a href="#">ModelDesk</a> on page 99.
Model Interface Package for Simulink	4.0	4.1	4.2	4.3 Refer to <a href="#">Model Interface Package for Simulink</a> on page 101.
MotionDesk	4.3	4.4	4.5	4.6 Refer to <a href="#">MotionDesk</a> on page 103.
MotionDesk Blockset	2.5.4	2.5.5	2.6	2.6.1 Refer to <a href="#">MotionDesk</a> on page 103.
Real-Time Testing	4.0	4.1	4.2	4.3 Refer to <a href="#">Real-Time Testing</a> on page 109.
RTI <sup>1)</sup>	7.11	7.12	7.13	7.14 Refer to <a href="#">RTI/RTI-MP and RTLib</a> on page 111.
RTI-MP <sup>2)</sup>	7.11	7.12	7.13	7.14 Refer to <a href="#">RTI/RTI-MP and RTLib</a> on page 111.
RTI Bypass Blockset	3.11	3.12	3.13	3.14 Refer to <a href="#">RTI Bypass Blockset</a> on page 115.
RTI CAN Blockset	3.4.7	3.4.8	3.4.9	3.4.10
RTI CAN MultiMessage Blockset	5.1	5.2	5.3	5.4 Refer to <a href="#">RTI CAN MultiMessage Blockset</a> on page 119.
RTI Electric Motor Control Blockset	1.4.1	1.4.1	1.4.1	1.4.1
RTI Ethernet Blockset	1.2.3	1.2.3	1.2.3	1.2.3
RTI Ethernet (UDP) Blockset	1.4.3	1.4.3	1.4.3	1.4.3
RTI FPGA Programming Blockset	3.6	3.7	3.8	3.9 Refer to <a href="#">RTI FPGA Programming Blockset</a> on page 123.
RTI LIN MultiMessage Blockset	3.1	3.2	3.3	3.4 Refer to <a href="#">RTI LIN MultiMessage Blockset</a> on page 129.
RTI RapidPro Control Unit Blockset	2.2.3	2.2.3	2.2.3	2.2.3
RTI Synchronized Time Base Manager Blockset	1.1	1.2	1.3	1.4 Refer to <a href="#">RTI Synchronized Time Base Manager Blockset</a> on page 131.

Product	dSPACE Release			
	2018-B	2019-A	2019-B	2020-A
RTI USB Flight Recorder Blockset	1.2.2	1.2.2	1.2.2	1.2.2
RTI Watchdog Blockset	2.1.1	2.1.1	2.1.1	2.1.1
Sensor Simulation	1.0	1.1	1.2	1.3 Refer to <a href="#">Sensor Simulation</a> on page 135.
SCALEXIO firmware	4.3	4.4	4.5	4.6 Refer to <a href="#">SCALEXIO Firmware</a> on page 133.
SYNECT	2.6	2.7	2.8	2.9 Refer to <a href="#">SYNECT</a> on page 137.
SystemDesk	5.2	5.3	5.4	5.4
TargetLink	4.4	4.4	5.0	5.0
Variable Editor <sup>3)</sup>	2.4	2.4	2.4	2.4
VEOS	4.3	4.4	4.5	5.0 Refer to <a href="#">VEOS</a> on page 151.

<sup>1)</sup> Including the standard I/O blocksets.

<sup>2)</sup> Including the RTI Gigalink Blockset.

<sup>3)</sup> The Variable Editor is not part of the dSPACE Release DVD. It is available at <https://www.dspace.com/go/requestreleasedownload>.

If you have not performed regular updates, refer to the *New Features and Migration* documents for the dSPACE Releases listed above for information about the new features and required migration steps.

## New Key Product Features

### Introduction

This is an overview of the new key features for each product. For more information, refer to the product-specific sections.

### AutomationDesk

The new key features of AutomationDesk are:

- New SYNECT interface providing access to SYNECT Test Management projects.
- Enhancements to the `_INFO_` namespace to get the current AutomationDesk version.
- Enhancements to the AutomationDesk COM API to get the current AutomationDesk version, the state of an execution, and a list of selected elements in the user interface.

For more information on the new features, refer to [New Features of AutomationDesk 6.3](#) on page 27.

**Bus Manager (stand-alone)**

The new key features of the Bus Manager (stand-alone) are:

- Enhanced J1939 support
- New frame gateway filters
- New and enhanced bus configuration features
- New Bus Manager tutorial

For more information, refer to [New Features of the Bus Manager \(Stand-Alone\) 6.5](#) on page 53.

**ConfigurationDesk (Implementation Version)**

The new key features of ConfigurationDesk are:

- New function blocks are available to support engine control I/O functionality and FuSa functionality on the MicroAutoBox III.
- Various function blocks now support the new SCALEXIO and MicroAutoBox III hardware (such as the DS1521).
- Various enhancements of the Bus Manager for configuring bus communication for simulation, inspection, and manipulation purposes.

For more information, refer to [ConfigurationDesk 6.5 - Implementation Version](#) on page 57.

**ControlDesk**

The new key features of ControlDesk 7.2 are:

**Platform/device enhancements**

- MicroAutoBox III: Support of the DS1521 Bus Board
- MicroAutoBox III: Support of CAN, Ethernet, and LIN bus channels
- SCALEXIO: Support of the DS6342 CAN Board and the DS6651 Multi-I/O Module
- MicroAutoBox III, SCALEXIO: Ethernet switch configuration

For more information, refer to [New Features of Platform Management and Platforms/Devices \(ControlDesk 7.2\)](#) on page 70.

**Layouting enhancement**

- Specifying layout descriptions

For more information, refer to [New Layouting Features \(ControlDesk 7.2\)](#) on page 71.

**Instrument enhancements**

- Display, Numeric Input, Variable Array: Support of 64-bit integer variables
- 3-D Viewer: Displaying surfaces
- 3-D Viewer: Specifying the pattern of point lines

For more information, refer to [New Instrument Features \(ControlDesk 7.2\)](#) on page 72.

**Measurement and recording enhancements**

- Configuring data logging on a MicroAutoBox III

For more information, refer to [New Measurement and Recording Features \(ControlDesk 7.2\)](#) on page 73.

#### **Bus Navigator enhancements**

- Improved replay of logged CAN data
- Bus monitoring devices: support of MicroAutoBox III bus interfaces
- Displaying Ethernet socket hierarchy
- Easier access to the definition, export, and import of Ethernet filters
- Bus Instruments: Status display

For more information, refer to [New Bus Navigator Features \(ControlDesk 7.2\)](#) on page 74.

---

#### **DCI Configuration Tool**

The new key feature of the DCI Configuration Tool is:

- Support of DCI-GSI2s with microcontrollers with JTAG/ARM target interface.

For more information on the new feature, refer to [New Features of the DCI Configuration Tool 3.12](#) on page 81.

---

#### **dSPACE ECU Flash Programming Tool**

The new key feature of the dSPACE ECU Flash Programming Tool is:

- Changes to the tool installation.

For more information on the new feature, refer to [New Features of the dSPACE ECU Flash Programming Tool 2.7](#) on page 83.

---

#### **dSPACE FlexRay Configuration Package**

The new key features of the dSPACE FlexRay Configuration Package are:

- Support of MicroAutoBox III systems with DS1521 Bus Board.
- Support of RX timestamps.
- Support of BITFIELD-TEXTTABLE computation method.

For more information on the new features, refer to [New Features of dSPACE FlexRay Configuration Package 4.5](#) on page 85.

---

#### **dSPACE XIL API**

There are no new features in the dSPACE XIL API .NET implementation. However, due to the discontinuation of dSPACE CAN API 1.0 and the DCI-CAN1 module, you might have to migrate your EESPort configuration files. Refer to [Migrating to dSPACE XIL API .NET 2020-A](#) on page 89.

---

#### **ECU Interface Manager**

The new key feature of the ECU Interface Manager is:

- ARM Cortex-R4/R5 microcontroller support

For more information on the new feature, refer to [New Features of ECU Interface Manager 2.7](#) on page 91.

---

**Firmware Manager**

The new key feature of the Firmware Manager is:

- Support of new hardware: DS1521, DS6342, and DS6651

For more information on the new features, refer to [New Features of Firmware Manager 3.1](#) on page 95.

---

**MicroAutoBox III firmware**

The new key features of the MicroAutoBox III firmware are:

- Support of the DS1521 Bus Board and the MicroAutoBox III Embedded PC.
- Support of functional safety monitoring features.
- Logging data on a USB mass storage device.

For more information on the new features, refer to [New Features of the MicroAutoBox III Firmware](#) on page 97.

---

**Model Interface Package for Simulink**

The new key features of Model Interface Package for Simulink are:

- Support of MATLAB R2020a.
- Support of variable-size signals.

For more information on the new features, refer to [Model Interface Package for Simulink](#) on page 101.

---

**ModelDesk**

The new key features of ModelDesk are:

- Road creation: Improvement of the OpenDRIVE import.
- Scenario creation:
  - Lane change maneuver in relation to the center lane or the ASM vehicle.
  - More reference points for specifying the distance [m].
- Parameterization: Parameter values can have 15 significant digits.
- Alias support: Added minimum and maximum values for alias variables.

For more information on the new features, refer to [New Features of ModelDesk 5.3](#) on page 99.

---

**MotionDesk**

The new key features of MotionDesk are:

- Material Database Editor: Manage the material database and add new custom materials and extended properties.
- Trajectories and markers: Generate the ModelDesk routes, trajectories, and markers in the 3-D scene.
- Display screen configuration: Configure the display screens in the MotionDesk options for sensor simulation and the observer view full screen mode to be displayed independently.
- Tool automation: Support for for ADAS and MicroAutoBox III and sensor information

- Observer navigation: A new observer navigation mode can be selected to move the observer around the 2-D and 3-D scenes using the mouse and mouse buttons.
- 3-D scene features: Observer view light and color controls and 3-D object visibility in the 3-D scene.
- Camera and fish-eye sensors configuration: Specify exposure, gamma correction, and material ID output settings and load the lens distortions from a look-up table.

For more information on the new features, refer to [MotionDesk Features \(MotionDesk 4.6\)](#) on page 104 and [Camera and Fish-Eye Sensor Features \(MotionDesk 4.6\)](#) on page 106.

### Python Extensions

The Python Extension 3.3 does not have new features.

As of dSPACE Release 2018-B, Python Extensions support Python 3.6. You have to migrate your custom scripts manually. For more information, refer to <http://www.dspace.com/go/Python36Migration> on the dSPACE website.

### RTI, RTI-MP, and RTLib

The new key features of RTI, RTI-MP, and RTLib are:

- Support of MATLAB R2020a.
- New dialogs in RTI and RTI-MP to specify the behavior of the first simulation steps for avoiding task overruns.

For more information on the new features, refer to [New Features of RTI/RTI-MP and RTLib](#) on page 111.

### RTI Bypass Blockset

The new key feature of the RTI Bypass Blockset is:

- On-target bypassing on virtual ECUs on MicroAutoBox III.

For more information on the new feature, refer to [New Features of the RTI Bypass Blockset 3.14](#) on page 115.

### RTI CAN MultiMessage Blockset

The new key features of the RTI CAN MultiMessage Blockset are:

- Support of SCALEXIO systems with a DS6342 CAN Board.
- Support of AUTOSAR ECU Extract.

For more information on the new features, refer to [New Features of the RTI CAN MultiMessage Blockset 5.4](#) on page 119.

### RTI FPGA Programming Blockset

The new key features of the RTI FPGA Programming Blockset 3.9 are:

- Extended Xilinx® software support.
- New *DS6651 Multi-I/O Module* framework to support the DS6651 Multi-I/O Module.
- Enhancements to the SCALEXIO and MicroAutoBox II/III frameworks.

For more information on the new features, refer to [New Features of the RTI FPGA Programming Blockset 3.9](#) on page 123.

---

**RTI LIN MultiMessage Blockset**

The new key feature of the RTI LIN MultiMessage Blockset is:

- Support of AUTOSAR ECU Extract.

For more information on the new feature, refer to [New Features of the RTI LIN MultiMessage Blockset 3.4](#) on page 129.

---

**SCALEXIO firmware**

The new key features of the SCALEXIO firmware are:

- Support of the DS6342 CAN Board
- Support of the DS6651 Multi-I/O Module

For more information on the new features, refer to [New Features of the SCALEXIO Firmware 4.6](#) on page 133.

---

**Sensor Simulation**

Sensor Simulation lets you to validate camera, fish-eye, laser, lidar, and radar sensors.

The new key features of Sensor Simulation are as follows:

- Ensure focus remains on the sensor composition window while a simulation is running.
- Animated characters support for all sensor types.
- SensorSim application headless mode.
- SensorSim application logging.

For more information on the new product, refer to [New Features of Sensor Simulation 1.3](#) on page 135.

---

**SYNECT**

The new key features of SYNECT 2.9 are:

- The SYNECT server now provides an OData service that lets you access data on the server.
- The AutomationDesk add-on now lets you synchronize SYNECT test management projects with custom libraries to support the teamwork of test managers and test developers.

For more information on the new features, refer to [New Features of SYNECT 2.9](#) on page 138.

---

**VEOS**

The new key features of VEOS are:

- Building offline simulation applications for Linux.
- Specifying additional code files for the FMU build process.

For more information on the new features, refer to [New Features of VEOS 5.0](#) on page 151.





# Aspects of Migrating from Previous Releases

---

## Introduction

After you install products of the current dSPACE Release, some additional steps might be required. The migration steps required when you update from the last dSPACE Release are described in the product-specific migration topics in this document. If you update from an earlier dSPACE Release, refer to the related *New Features and Migration* document.

## Migrating to dSPACE Release 2020-A

---

### Introduction

After you install Release 2020-A, some additional steps might be required.

---

### Migrating from dSPACE Release 2019-B

**Product-specific migration steps** Product-specific migration steps are generally performed automatically. For exceptions, refer to the product-specific migration descriptions.

---

### Migrating from dSPACE Release 2019-A or earlier

To migrate from dSPACE Release 2019-A or earlier to Release 2020-A, you also have to perform the migration steps of the intervening dSPACE Releases. All of the required migration steps can be performed using the software from dSPACE Release 2020-A.

For more information on the required migration steps, refer to the *New Features and Migration* documents of the intervening dSPACE Releases.

---

### Previous release documents

The PDF files of previous Releases are called `NewFeaturesAndMigrationxx.pdf`, where xx stands for the Release number.

You can find the *New Features and Migration* files for previous Releases in the following locations:

- In the installation folder of the current dSPACE Help. Refer to `C:\Program Files\Common Files\dSPACE\Help 2020-A\Print\PreviousReleases`.
- On the dSPACE DVDs. Refer to `\Doc\PreviousReleases`.
- At [www.dspace.com/go/migration](http://www.dspace.com/go/migration) for download. Here, you can also find *New Features and Migration* documents for very early Releases.

# AutomationDesk

## Where to go from here

## Information in this section

New Features of AutomationDesk 6.3.....	27
Migrating to AutomationDesk 6.3.....	28

## New Features of AutomationDesk 6.3

### General enhancements

**SYNECT interface** The SYNECT interface provides access to SYNECT Test Management projects. The interface uses the OData service of the SYNECT server introduced with the new version 2.9. Refer to [SYNECT](#) on page 137. For a connected SYNECT Test Management project, AutomationDesk is able to detect and resolve inconsistencies between the corresponding elements in SYNECT and in AutomationDesk.

For the creation of elements, the update of modified elements, and for resolving detected inconsistencies, you can decide whether to synchronize AutomationDesk with the elements configured in SYNECT by using the **Pull** command, or to synchronize SYNECT with the elements configured in AutomationDesk by using the **Push** command.

If an AutomationDesk element is connected to SYNECT, the element's symbol is additionally marked with the  symbol that is also used in SYNECT for test case management.

For more information, refer to [SYNECT](#) ( [AutomationDesk Basic Practices](#)).

**\_INFO\_ namespace** With the `_INFO_` namespace, you can get the current AutomationDesk version either in its entirety by using `_INFO_.Version`, which returns, e.g., 6.3.0. You can also get the major, minor and revision versions separately by using `_INFO_.Version.Major`, `_INFO_.Version.Minor`, and `_INFO_.Version.Revision`, respectively.

### Enhancements to the COM API

The AutomationDesk COM API provides the following enhancements:

- The **TAMVersion** object provides the following properties to get the elements of the current version separately:
  - **Major**
  - **Minor**
  - **Revision**
- You can use the **Selection** property for the **Application** object to get a collection of elements that are currently selected in the AutomationDesk user interface.
- You can use the **IsExecutionRunning** property for the **ExecutionConfiguration** object to check the status of the execution.

For more information, refer to [AutomationDesk Automation](#).

## Migrating to AutomationDesk 6.3

### General migration aspects

If you open an AutomationDesk project with a later AutomationDesk version, the software automatically detects whether a migration is required. For AutomationDesk projects that are saved in the legacy format, i.e., that were created with AutomationDesk 6.1 or earlier, you must click **OK** in the message dialog to start the migration. The migration of AutomationDesk projects in the new XML format must not be confirmed. Save the migrated project to another path or name.

An AutomationDesk project loaded and saved in AutomationDesk 6.3 can be opened in AutomationDesk 6.2. The different schema versions are then displayed in a warning message. It might not be possible to execute the project with the earlier AutomationDesk version.

#### Note

Before you open an older project with the new AutomationDesk version, make sure that the following preconditions are fulfilled:

- You must create backups of the project and of the linked custom libraries.
- AutomationDesk must be running properly. The Log Viewer must not display any error messages.
- The built-in libraries, required custom libraries, and other packages must be loaded properly.

If you use a version control system, there are some preconditions for successful migration. Refer to [How to Migrate Projects or Custom Libraries Under Version Control](#) ([AutomationDesk Basic Practices](#)).

For more information, refer to [Migrating AutomationDesk](#) ([📖 AutomationDesk Introduction And Overview](#)).

#### Note

As of dSPACE Release 2018-B, AutomationDesk has supported Python 3.6. You find information on changes and migration aspects of Python scripts in dSPACE products on the dSPACE website. Refer to <http://www.dspace.com/go/Python36Migration>.

### Migration to the new serialization format introduced with AutomationDesk 6.2

If you open an AutomationDesk project or a custom library created with AutomationDesk 6.1 or earlier, the data is automatically migrated to the new XML format. The migration considers the standard serialization format, exported projects and custom libraries in ZIP format, and exported projects and custom libraries in the legacy XML format.

If you use a version control system, you can get and open projects and custom libraries in the legacy formats. They are automatically migrated to the new serialization format and lose their connections to the version control system. You must add the migrated projects and custom libraries to new version control projects to avoid mixing the formats in the repository. For more information, refer to [How to Migrate Projects or Custom Libraries Under Version Control](#) ([📖 AutomationDesk Basic Practices](#)).

### Libraries

**ControlDesk Access library** With ControlDesk 7.2, the following features changed. This also affects the ControlDesk Access library in AutomationDesk.

- Discontinuation of the IDF format

As of ControlDesk 7.2, you can no longer record data in the IDF format. If you use the `GetRecordedData` or `StopMeasurementAndRecording` blocks in AutomationDesk with an IDF file specified for the `IDFFile` data object, an exception occurs. Use the MF4, CSV, or MAT file formats for the `IDFFile` data object instead. For best performance, use the MF4 file format, because the data is recorded in this format. The other file formats are created by converting the MF4 data.

For more information, refer to [📖 AutomationDesk Accessing ControlDesk](#).

**ModelDesk Access library** Up to and including ModelDesk 5.2, you can use the maneuver compatibility mode in ModelDesk to work with maneuvers created with ModelDesk 4.6 and earlier.

As of ModelDesk 5.3, the maneuver compatibility mode is discontinued. Maneuvers created with ModelDesk 4.6 and earlier are no longer supported. Executing ModelDesk Access blocks to activate and download these maneuvers leads to exceptions.

**Remote Diagnostics (COM) library** The use of DCI-CAN1 as the CAN interface for a logical link in a diagnostic system is discontinued, refer to [Discontinuations](#) on page 14. You must migrate your diagnostic system and adapt your AutomationDesk sequence accordingly.

**Discontinued libraries and blocks**

If you open a project containing discontinued elements in AutomationDesk 6.3, the discontinued data objects are replaced by Discontinued data object data objects and the discontinued blocks are replaced by Discontinued block blocks during the automatic project update. This lets you load your projects and search for blocks and data objects to be migrated. If you execute a project containing elements of a discontinued library via AutomationDesk or an API script, project execution will stop with an exception.

The following libraries are discontinued:

- CANScope
- CANstress

Neither library was included in the standard distribution, but were available on demand. AutomationDesk versions as of Release 2020-A no longer supports these libraries.

For more information on migration aspects, refer to [Migrating AutomationDesk](#) ( [AutomationDesk Introduction And Overview](#)).

---

**Planned discontinuations**

**MATLAB Access library** As of Release 2020-B, the following automation blocks will be discontinued:

- HideApplication
- ShowApplication
- MinimizeCommandWindow
- RestoreCommandWindow

When working with MATLAB R2020a and AutomationDesk 6.3, the use of these automation blocks might not have any effect due to a changed behavior of MATLAB.

# Automotive Simulation Models (ASM)

## Where to go from here

## Information in this section

All ASM Products.....	32
ASM Base InCylinder.....	33
ASM Diesel Engine.....	34
ASM Diesel Exhaust.....	37
ASM Diesel InCylinder.....	38
ASM Drivetrain Basic.....	39
ASM Electric Components.....	40
ASM Environment.....	42
ASM Gasoline Engine Basic.....	44
ASM Gasoline Engine.....	45
ASM Gasoline InCylinder.....	48
ASM Traffic.....	49
ASM Utils.....	51
ASM Vehicle Dynamics.....	52

## All ASM Products

### Migrating All ASM Blocksets

---

**Platform support**

As of Release 2020-A, the DS1005 Processor Board is no longer supported



# ASM Base InCylinder

## Migrating to ASM Base InCylinder Blockset 2.6.1

---

### **MAP\_CYL2EXHCAM and MAP\_CYL2INCAM blocks**

The MAP\_CYL2EXHCAM and MAP\_CYL2INCAM blocks are obsolete and have been removed from the library.

If you copied them to your model, contact [support.asm@dSPACE.de](mailto:support.asm@dSPACE.de) for help on resolving the missing links.

---

### **Related topics**

#### Basics

[Migrating ASM Models](#) ( ASM User Guide)

# ASM Diesel Engine

## Where to go from here

## Information in this section

New Features of ASM Diesel Engine Blockset 2.7.1.....	34
Changes in the ASM Diesel Engine Demo Model.....	34
Migrating to ASM Diesel Engine Blockset 2.7.1.....	35

## New Features of ASM Diesel Engine Blockset 2.7.1

### V engine capability

Vector capability was introduced for all combustion blocks to simulate V engines. You can select possible V engine parameterizations for the `ENGINE_SETUP` block in ModelDesk.

### COMBUSTION\_TEMPERATURE\_CI block

This block is new. It calculates the combustion temperature that was previously calculated in the `COMBUSTION_TORQUE_CI` block.

### MASS\_FRACTION block

This block is new. It is used to compute the mass flow and gas components during combustion. It includes calculations of mass fractions for unburned fuel, unburned air, exhaust, and lambda.

### PUMP\_TORQUE block

The torque calculation now supports two stroke engines.

## Changes in the ASM Diesel Engine Demo Model

### Mapping blocks for V engine capability

Different mapping blocks have been introduced to combine, split, or route vector signals through the model.

### Unburned fuel mass flow

Unburned fuel during combustion can now be simulated and is routed back into the combustion chamber through exhaust gas recirculation and intake manifold.

## Migrating to ASM Diesel Engine Blockset 2.7.1

---

<b>IDLE_SPEED_CONTROL block</b>	The size of the Map_Trq_Engine_Max parameter was changed from [14,2] to [21,2] values.
---------------------------------	--

---

<b>DIRECTINJECTOR block</b>	The description of the Sw_InjMode parameter was changed from [1Mean] 2Pulse] to [1Pulse]2Mean]. The functionality of the block was not modified. You have to modify the parameter comment and the real-time path in your ControlDesk experiment.
-----------------------------	--

---

<b>ENGINE_SETUP block</b>	<p>The block has new parameters to support V engines:</p> <ul style="list-style-type: none"><li>▪ Const_max_num_InMan</li><li>▪ Const_max_num_ExhMan</li><li>▪ Const_num_InMan</li><li>▪ Const_num_ExhMan</li><li>▪ Map_InMan2Cyl</li><li>▪ Map_ExhMan2Cyl</li></ul> <p>Calculations for active V engine components and cylinder distributions were added to the block.</p>
---------------------------	---

---

<b>CYLINDER_INLET block</b>	<p>The memory blocks for loop prevention were moved to the demo model.</p> <p>Relative air mass and fuel mass flow calculations were introduced to the block.</p> <p>V engine support is now taken into account for all equations.</p>
-----------------------------	--

---

<b>COMBUSTION_TORQUE_CI block</b>	<p>The calculations of combustion temperature and overall lambda values were moved to other blocks.</p> <p>V engine support is now taken into account for all equations.</p>
-----------------------------------	--

---

<b>SOFTECU_SETUP block</b>	New signals from the engine are routed through.
----------------------------	---

---

<b>COMBUSTION_TORQUE_CI_11_0 block</b>	This block contains the structure and equations of a former block version.
--	--

**SWITCHES\_COMBUSTION\_3\_0 block** This block contains the structure and equations of a former block version.

---

**Related topics**

**Basics**

[Migrating ASM Models \(📖 ASM User Guide\)](#)

# ASM Diesel Exhaust

## Migrating to ASM Diesel Exhaust Blockset 2.1.10

---

**DIESEL\_OXIDATION\_CATALYST block**      The block has new parameters: Const\_m\_Heater and Const\_Conduct.

---

**ADBLUE\_PUMP block**      The block has a new parameter: Sw\_Source\_U.  
The block has a new inport: U\_Bat[V].

---

**ASMSignalBus**      The ASMSignalBus contains a new signal: T\_In\_Muffler[degC].

---

### Related topics

#### Basics

[Migrating ASM Models \(📖 ASM User Guide\)](#)

# ASM Diesel InCylinder

## Migrating to ASM Diesel InCylinder Blockset 2.7.2

---

**IDLE\_SPEED\_CONTROL block**      The size of the Map\_Trq\_Engine\_Max parameter was changed from [14,2] to [21,2] values.

---

### Related topics

#### Basics

[Migrating ASM Models \(📖 ASM User Guide\)](#)

# ASM Drivetrain Basic

## Migrating to ASM Drivetrain Basic Blockset 5.3.2

---

**ENGINE\_DATA block**

The size of the Map\_Trq\_Engine\_Max parameter was changed from [14,2] to [21,2] values.

---

**Related topics****Basics**

[Migrating ASM Models](#) ( ASM User Guide)

# ASM Electric Components

## Where to go from here

## Information in this section

New Features of ASM Electric Components Blockset 3.10.....	40
Changes in the ASM Electric Components Demo Model.....	40
Migrating to ASM Electric Components Blockset 3.10.....	40

## New Features of ASM Electric Components Blockset 3.10

### **BATTERY\_MULTICELL block**

The accuracy of the electromotive force cell voltage in dependence of the SOC of each individual cell has been improved.

## Changes in the ASM Electric Components Demo Model

### **THREE\_PHASE\_DCM\_INVERTER block**

The THREE\_PHASE\_INVERTER block was replaced by the THREE\_PHASE\_DCM\_INVERTER block in the Electrical Drive Closed Loop PMSM Nonlinear demo model to simulate the operation of a three-phase load with missing driver signals of the power switches (e.g., for HSDa and LSDa).

### **Sample time**

The sample time of all Electrical Drive Closed Loop demo models was set to  $50 \mu\text{s}$  as default.

## Migrating to ASM Electric Components Blockset 3.10

### **BATTERY\_MULTICELL block**

The accuracy of the electromotive force cell voltage in dependence of the SOC of each individual cell was improved so that the model provides a more precise simulation.

The former simulation behavior cannot be automatically ensured via migration. During the migration of older ASM models, the link to the battery multicell library is changed to the former implementation in the



FormerVersion/BATTERY\_MULTICELL\_11\_0 subsystem. This way, the simulation behavior does not change.

To use the new implementation in your model, drag the BATTERY\_MULTICELL block from the library to your model and adapt the inports, outports, and parameters to your requirements.

**Note**

If you use the Operator version of the Engine Gasoline Hybrid demo model, migration issues can occur because the BATTERY\_MULTICELL\_11\_0 block is not part of the ASM Electric Components Operator Library. To solve this issue, drag the new BATTERY\_MULTICELL block to the the model and adapt the initialization files accordingly.

---

**Related topics****Basics**

[Migrating ASM Models](#) (📖 ASM User Guide)

## ASM Environment

### Where to go from here

### Information in this section

New Features of ASM Environment Blockset 4.12.....	42
Migrating to ASM Environment Blockset 4.12.....	42

## New Features of ASM Environment Blockset 4.12

### MANEUVER\_SCHEDULER block

The MANEUVER\_SCHEDULER block now supports the usage of absolute lane indices.

The MANEUVER\_SCHEDULER block now supports lane changes of the ego-vehicle to a lane that is defined relative to the current lane of the ego-vehicle.

### GPS\_POSITION block

This block now also calculates the heading angle of the vehicle.

Vectorized calculation is now also enabled. This block is now able to handle vectorized input signals.

### ROAD block

The ROAD block now supports the usage of incoming absolute lane indices.

## Migrating to ASM Environment Blockset 4.12

### MANEUVER\_SCHEDULER\_18\_0 block

The MANEUVER\_SCHEDULER\_18\_0 block is no longer supported.

### Maneuver compatibility mode

As of Release 2020-A, maneuvers defined with the Maneuver Editor can no longer be used.

### LANE\_NETWORK block

Three inports have been added to the LANE\_NETWORK block. With these new inports, the LANE\_NETWORK block can be controlled by the new OSI\_GROUNDTRUTH\_INTERFACE block of the ASM Traffic Library.

---

**LATERAL\_CONTROL1 block**

The vehicle behavior when driving backwards at low velocities has been improved.

---

**Related topics**

Basics

[Migrating ASM Models \(📖 ASM User Guide\)](#)

# ASM Gasoline Engine Basic

## Where to go from here

## Information in this section

Changes in the ASM Engine Gasoline Basic Demo Model.....	44
Migrating to ASM Gasoline Engine Basic Blockset 2.2.5.....	44

## Changes in the ASM Engine Gasoline Basic Demo Model

### Demo discontinuation

As of this Release, the ASM Gasoline Engine Basic demo model is not available for new projects. However, the legacy support via migration for existing models is provided up to and including dSPACE Release 2020-B. Use the advanced ASM Gasoline Engine or ASM Gasoline InCylinder Engine demo models for new gasoline engine projects.

## Migrating to ASM Gasoline Engine Basic Blockset 2.2.5

### IDLE\_SPEED\_CONTROL block

The size of the Map\_Trq\_Engine\_Max parameter was changed from [14,2] to [21,2] values.

## Related topics

### Basics

[Migrating ASM Models \(📖 ASM User Guide\)](#)

# ASM Gasoline Engine

## Where to go from here

## Information in this section

New Features of ASM Gasoline Engine Blockset 4.1.1.....	45
Changes in the ASM Engine Gasoline Demo Model.....	45
Migrating to ASM Gasoline Engine Blockset 4.1.1.....	46

## New Features of ASM Gasoline Engine Blockset 4.1.1

<b>V engine capability</b>	Vector capability was introduced for all combustion blocks to simulate V engines. You can select possible V engine parameterizations for the <code>ENGINE_SETUP</code> block in ModelDesk.
<b>COMBUSTION_TEMPERATURE_CI block</b>	This block is new. It calculates the combustion temperature that was previously calculated in the <code>COMBUSTION_TORQUE_CI</code> block.
<b>COMBUSTION_TEMPERATURE_SI block</b>	This block is new. It calculates the temperature for homogeneous combustion that was previously calculated in the <code>COMBUSTION_TORQUE_SI</code> block.
<b>MASS_FRACTION block</b>	This block is new. It is used to compute the mass flow and gas components during combustion. It includes calculations of mass fractions for unburned fuel, unburned air, exhaust, and lambda.
<b>PUMP_TORQUE block</b>	The torque calculation now supports two stroke engines.

## Changes in the ASM Engine Gasoline Demo Model

<b>Mapping blocks for V engine capability</b>	Different mapping blocks have been introduced to combine, split, or route vector signals through the model.
---	---

## Migrating to ASM Gasoline Engine Blockset 4.1.1

<b>IDLE_SPEED_CONTROL block</b>	The size of the Map_Trq_Engine_Max parameter was changed from [14,2] to [21,2] values.
<b>FRICTION_TORQUE block</b>	The name of the block in the ASMSignalBus has been changed from Friction_Torque to Friction. The signal name on the bus has also been renamed from Trq_Engine_MeanFric[Nm] to Trq_Fric_Engine[Nm]. During the migration process, the original signal names are restored.
<b>ENGINE_SETUP block</b>	<p>The block has new parameters to support V engines:</p> <ul style="list-style-type: none"> <li>▪ Const_max_num_InMan</li> <li>▪ Const_max_num_ExhMan</li> <li>▪ Const_num_InMan</li> <li>▪ Const_num_ExhMan</li> <li>▪ Map_InMan2Cyl</li> <li>▪ Map_ExhMan2Cyl</li> </ul> <p>Calculations for active V engine components and cylinder distributions were added to the block.</p>
<b>CYLINDER_INLET block</b>	<p>Memory blocks for loop prevention were moved to the demo model.</p> <p>The parameter for relative air mass calculation was replaced by an ENGINE_SETUP signal.</p> <p>V engine support is now taken into account for all equations.</p>
<b>COMBUSTION_TORQUE_CI and COMBUSTION_TORQUE_SI blocks</b>	<p>The blocks now have the same block structure.</p> <p>The calculations for combustion temperature and overall lambda values were moved to other blocks.</p> <p>The V engine support is now taken into account for all equations.</p>
<b>SOFTECU_SETUP block</b>	New signals from the engine are routed through.
<b>WALL_FILM block</b>	The integrator was changed from <i>continuous</i> to <i>discrete</i> and now has an external reset.
<b>COMBUSTION_MODE_SWITCH block</b>	The mass fraction and lambda calculations are now performed by different blocks and their equations.

---

**CYLINDER\_INLET\_6\_0 block** This block contains the structure and equations of a former block version.

---

**COMBUSTION\_TORQUE\_CI\_7\_0 block** This block contains the structure and equations of a former block version.

---

**COMBUSTION\_TORQUE\_SI\_7\_0 block** This block contains the structure and equations of a former block version.

---

**COMBUSTION\_MODE\_SWITCH\_4\_0 block** This block contains the structure and equations of a former block version.

---

**SWITCHES\_TRQ\_COMB\_MODE\_1\_0 block** This block contains the structure and equations of a former block version.

---

#### Related topics

##### Basics

[Migrating ASM Models \(📖 ASM User Guide\)](#)

# ASM Gasoline InCylinder

## Migrating to ASM Gasoline InCylinder Blockset 2.7.2

---

**IDLE\_SPEED\_CONTROL block**      The size of the Map\_Trq\_Engine\_Max parameter was changed from [14,2] to [21,2] values.

---

### Related topics

#### Basics

[Migrating ASM Models \(📖 ASM User Guide\)](#)



# ASM Traffic

## Where to go from here

## Information in this section

New Features of ASM Traffic Blockset 4.1.....	49
Changes in the ASM Traffic Demo Model.....	50
Migrating to ASM Traffic Blockset 4.1.....	50

## New Features of ASM Traffic Blockset 4.1

### **OBJECT\_SENSOR\_3D\_CALCULATION block**

The output of the block has been extended. The block now also provides the target velocity and acceleration for each component in the sensor coordinate system (x, y, z).

### **CUSTOM\_POINTS block**

The output of the block has been extended. The block now also provides the target velocity and acceleration for each component in the sensor coordinate system (x, y, z).

### **RADAR\_RCS\_NOISE block**

The block now supports reproducible random numbers. It has a new reset input and a seed parameter for defining the sequence of random numbers.

### **RADAR\_MEASUREMENT\_NOISE block**

The block now supports reproducible random numbers. It has a new reset input and a seed parameter for defining the sequence of random numbers.

### **TRAFFIC\_SCHEDULER block**

The TRAFFIC\_SCHEDULER block now supports the usage of absolute lane indices. It now supports lane changes of a fellow to a lane defined relative to the current lane of the fellow vehicle.

### **OSI\_GROUNDTRUTH\_INTERFACE block**

The new OSI\_GROUNDTRUTH\_INTERFACE block provides OSI (Open Simulation Interface) data in a data structure (for OSI 3.0 and 3.1). The data can be sent via OSI-Send blocks. These are provided on demand (due to version- and platform dependencies).

## Changes in the ASM Traffic Demo Model

---

### GroundTruth model

The ASM Traffic demo model has been extended by the GroundTruth subsystem. This subsystem contains the new `OSI_GROUNDTRUTH_INTERFACE` block.

## Migrating to ASM Traffic Blockset 4.1

---

### CUSTOM\_POINTS block

The `CUSTOM_POINTS` block has been extended by new outports for the component-by-component velocity and the acceleration calculation.

### RADAR\_RCS\_NOISE block

The new seed parameter is set to a default value. It is recommended to change the value to a random integer.

### RADAR\_MEASUREMENT\_NOISE block

The new seed parameter is set to a default value. It is recommended to change the value to a random integer.

### TRAFFIC\_SCHEDULER block

The `TRAFFIC_SCHEDULER` block has been extended by new outports for the support of absolute lane indices.

### Related topics

#### Basics

[Migrating ASM Models \(📖 ASM User Guide\)](#)

# ASM Utils

## New Features of ASM Utils 4.1.3

---

### 'asm\_proc' function

ModelDesk increases parameter precision from 6 to 14 significant digits. Most applications do not require this precision. If you use ModelDesk Processing, e.g., in table generation, the `asm_proc` function rounds to 6 significant digits by default.

For information on changing this behavior, refer to the new `set_round` method of the `asm_proc` function.

# ASM Vehicle Dynamics

## Where to go from here

## Information in this section

<a href="#">New Features of ASM Vehicle Dynamics Blockset 4.1.3.....</a>	<a href="#">52</a>
<a href="#">Migrating to ASM Vehicle Dynamics Blockset 4.1.3.....</a>	<a href="#">52</a>

## New Features of ASM Vehicle Dynamics Blockset 4.1.3

### Adams2ASM Converter

In addition to the steering rod displacement, the steering wheel angle can now be selected as an input variable in the Adams simulation environment (for independent suspensions).

## Migrating to ASM Vehicle Dynamics Blockset 4.1.3

### Adams2ASM Converter

A bug was fixed which caused the kinematic data from the Adams simulation to be read incorrectly by the converter in MATLAB.

## Related topics

### Basics

[Migrating ASM Models \(📖 ASM User Guide\)](#)

# Bus Manager (Stand-Alone)

## New Features of the Bus Manager (Stand-Alone) 6.5

### Enhanced J1939 support

**Support of J1939 transport protocols** The Bus Manager now supports the Broadcast Announce protocol and Connection Mode Data Transfer protocol.

If you use a DBC file as a communication matrix that sets up J1939 communication by using transport protocols, you can work with J1939-compliant ISignal IPDUs with up to 1,785 data bytes in bus configurations.

**Support of static network management according to J1939-81** The Bus Manager now supports static network management according to J1939-81. For this purpose, a new J1939 Network Management Enable bus configuration feature is available. When you add the feature to a communication controller, the related J1939 network node can send and respond to received address claims. In case of an address conflict, the network node stops its J1939 communication if it cannot claim the requested address due to its priority.

For more information, refer to [Aspects of Supported CAN Bus Features \(Bus Manager \(Stand-Alone\) Implementation Guide\)](#).

### Filtering CAN frame gateways

The Bus Manager now lets you filter CAN frames for gatewaying. For each communication cluster of a Frame Gateway, you can specify filter rules and specify whether the frames that pass the filter rules are included or excluded from being gatewayed.

For more information, refer to [Specifying Gateway Filters \(Bus Manager \(Stand-Alone\) Implementation Guide\)](#).

### Enhanced bus configuration features

**PDU Raw Data feature** You can now add the PDU Raw Data feature to any RX and TX PDU that is assigned to the Simulated ECUs or Inspection part of a bus configuration. By default, this lets you read the payload of the RX or TX PDU in raw data format, and access the data via experiment software. Depending on the PDU type of TX PDUs, you can additionally switch the access mode to write raw data to the payload of TX PDUs.

For more information, refer to [Accessing the Payload of PDUs in Raw Data Format](#) ([📖 Bus Manager \(Stand-Alone\) Implementation Guide](#)).

**PDU User Code feature** The PDU User Code feature is now also available as a bus manipulation feature.

For more information, refer to [Applying User Code to PDUs](#) ([📖 Bus Manager \(Stand-Alone\) Implementation Guide](#)).

**Bus manipulation features that affect secure onboard communication** For bus manipulation features that affect secure onboard communication (SecOC), you can now recalculate the authentication information of the related secured IPDUs. When you do this, you can prevent the bus manipulation features from unintentionally invalidating the authentication information.

For more information, refer to [Basics on Bus Manipulation Features](#) ([📖 Bus Manager \(Stand-Alone\) Implementation Guide](#))

---

### Enhanced support of CAN and LIN communication

The Bus Manager now provides the following enhancements for CAN and/or LIN communication:

- Support of array signals of UInt8 data type and opaque byte order
- Support of the following AUTOSAR-compliant triggering options for container IPDUs with static container layout:
  - Container timeout
  - Container IPDU trigger mode
  - PDU collection trigger mode
- Support of CAN PDUs for which the communication matrix does not specify a sending or receiving ECU. If you add such a communication matrix to the ConfigurationDesk application, a `DS_UnknownSender` or `DS_UnknownReceiver` ECU is generated during the import process and the affected PDUs are assigned to the related ECU.

---

### Generating bus simulation containers for offline simulation applications on Linux

The Bus Manager now lets you generate bus simulation containers (BSC files) that can be used in offline simulation applications that are built for execution on a Linux operating system. For this purpose, you do not have to make any manual configurations. Instead, you only have to include 64-bit Simulink implementation containers (SIC files) in the bus simulation containers.

---

### Basic ARXML communication matrix

The Bus Manager now provides a basic communication matrix, which is an AUTOSAR system description file (ARXML file). You can use this file as a starting point to set up simple CAN communication. For this purpose, you can modify the file in the ConfigurationDesk application, and assign elements to bus configurations.

For more information, refer to [Basics on Modifying Communication Matrices](#) ([📖 Bus Manager \(Stand-Alone\) Implementation Guide](#)).

**Bus Manager tutorial**

The Bus Manager now provides a Bus Manager tutorial. The tutorial guides you through the basic steps when you start working with the Bus Manager, and covers typical use scenarios. For more information, refer to  [Bus Manager Tutorial](#).





# ConfigurationDesk 6.5 - Implementation Version

**Introduction** With ConfigurationDesk's Implementation version you can implement real-time applications for the SCALXIO hardware or the MicroAutoBox III hardware.

**Where to go from here**

**Information in this section**

New Features of ConfigurationDesk.....	57
New Features Concerning I/O Functionality and Hardware Support.....	60
New Features of the Bus Manager in ConfigurationDesk.....	63
Supported Container File Versions.....	65
Migrating to ConfigurationDesk 6.5.....	67

## New Features of ConfigurationDesk

**New features of multimodel application processes**

**Automatic configuration optimization in multimodel application processes** ConfigurationDesk now lets you automatically optimize the configuration of a multimodel application process. You can enable or disable the automatic configuration optimization via the Optimize configuration automatically checkbox for an application process. Additionally, you can use the Optimize configuration automatically checkbox on the Configuration page of the Options dialog to specify the default behavior of this application process property. Refer to [Using Multiple Model Implementations in the Same Application Process](#) ( ConfigurationDesk Real-Time Implementation Guide).

**New model communication features**

**Support of variable-size signals** ConfigurationDesk lets you establish model communication with variable-size model ports. Refer to [Working with Model Port Blocks That Provide Variable-Size Signals](#) ([📖 ConfigurationDesk Real-Time Implementation Guide](#)).

**New BSC file features**

**Generation and support of precompiled BSC files** ConfigurationDesk now provides methods to precompile bus simulation container files (BSC files). You can add precompiled BSC files to a ConfigurationDesk application. Refer to [Creating Precompiled BSC Files](#) ([📖 ConfigurationDesk Real-Time Implementation Guide](#)).

**Note**

You cannot use precompiled BSC files in VEOS.

**Support of BSC files and bus configurations in the same application process** An application process can now contain any number of BSC files and bus configurations.

**New FMU features**

**Support of initial values for string variables** You can specify initial values for variables with the `string` data type via the `start` attribute in the `modelDescription.xml` file.

**Note**

ConfigurationDesk does not generate TRC file entries for variables with the `string` data type.

Refer to [Workflow for Integrating FMUs in Executable Applications](#) ([📖 ConfigurationDesk Real-Time Implementation Guide](#)).

**New feature for SCALEXIO Processing Units**

**Support of non-volatile memory access on SCALEXIO Processing Units** ConfigurationDesk now supports accessing the non-volatile memory of SCALEXIO Processing Units. Real-time applications can write and read own data to and from the non-volatile memory as well as read data stored by other real-time applications. Refer to [Non-Volatile Memory Access](#) ([📖 ConfigurationDesk I/O Function Implementation Guide](#)).

**New V-ECU implementation features**

**Support of V-ECU implementations on MicroAutoBox III** ConfigurationDesk applications that contain application processes to which V-ECU implementations are assigned can now be built for use on a MicroAutoBox III.

**Support of V-ECU implementations with virtual bypassing** You can now use V-ECU implementations in real-time applications that are prepared for virtual bypassing. Refer to [Working with V-ECU Implementations That Provide Virtual Bypassing Support](#) ( [ConfigurationDesk Real-Time Implementation Guide](#)).

**Note**

Real-time applications containing such V-ECU implementations can be built only for use on a MicroAutoBox III.

**Basic support of CAN and LIN modules for MCAL** ConfigurationDesk now supports V-ECU implementations that provide CAN interfaces and LIN interfaces on the microcontroller abstraction layer (MCAL) level. The following MCAL modules are supported:

- CANDrv
- LINDrv

Refer to [Basics on V-ECU Implementations](#) ( [ConfigurationDesk Real-Time Implementation Guide](#)).

---

**New documentation features**

**Demo project descriptions** You can now find descriptions for most ConfigurationDesk demo projects starting from an overview that helps you to decide which demo project might be relevant for you. Refer to [Overview of ConfigurationDesk Demo Projects](#) ( [ConfigurationDesk Demo Projects](#)).

**MicroAutoBox III tutorial** The ConfigurationDesk MicroAutoBox III tutorial shows you the basic configuration steps when you want to use MicroAutoBox III hardware and engine control I/O functionality in ConfigurationDesk. Refer to  [ConfigurationDesk Tutorial MicroAutoBox III](#).

---

**New features of the tool automation interface**

The ConfigurationDesk automation interface supports additional ConfigurationDesk features. For more information, refer to [New Features and Changes to the Automation Interface for Release 2020-A](#) ( [ConfigurationDesk Automating Tool Handling](#)).

## New Features Concerning I/O Functionality and Hardware Support

### New function block types

The table below shows the new function block types:

Function Block	Description	Supported Hardware	Channel Types	Further Information
Engine Control Setup	The Engine Control Setup function block specifies basic characteristics of an existing (real) piston engine that you want to control. The function block works as a provider: Other function blocks can use it to obtain information on the characteristics of the specified piston engine.	DS1554 (MicroAutoBox III)	-	<a href="#">Engine Control Setup</a> ( <a href="#">📖 ConfigurationDesk I/O Function Implementation Guide</a> )
Engine Angular Pulse Out	The Engine Angular Pulse Out function block generates a periodic pulse pattern based on engine position data retrieved from an assigned master APU provider. The generated pulse pattern can be used, for example, for starting A/D conversions.	DS1554 (MicroAutoBox III)	<ul style="list-style-type: none"> <li>▪ Digital In/Out 8</li> <li>▪ Digital Out 7</li> </ul>	<a href="#">Engine Angular Pulse Out</a> ( <a href="#">📖 ConfigurationDesk I/O Function Implementation Guide</a> )
Crank In	The Crank In function block type lets you measure the crankshaft of a piston engine and calculates the current position, speed and rotational direction of the engine. For performing these measurements, the Crank In function block must be used in combination with at least one Cam In function block.	DS1554 (MicroAutoBox III)	<ul style="list-style-type: none"> <li>▪ Digital In 9</li> <li>▪ Digital In 10</li> </ul>	<a href="#">Crank In</a> ( <a href="#">📖 ConfigurationDesk I/O Function Implementation Guide</a> )
Cam In	The Cam In function block type lets you measure the phase shift angle between a camshaft and the coupled crankshaft. Cam In must be used with the Crank In function block for synchronizing with the provided master APU and to evaluate the current engine position.	DS1554 (MicroAutoBox III)	<ul style="list-style-type: none"> <li>▪ Digital In 9</li> <li>▪ Digital In 10</li> </ul>	<a href="#">Cam In</a> ( <a href="#">📖 ConfigurationDesk I/O Function Implementation Guide</a> )

Function Block	Description	Supported Hardware	Channel Types	Further Information
Ignition Out	The Ignition Out function block type lets you generate ignition pulses for a real piston engine.	DS1554 (MicroAutoBox III)	<ul style="list-style-type: none"> <li>▪ Digital In/Out 8</li> <li>▪ Digital Out 7</li> </ul>	<a href="#">Ignition Out</a> ( <a href="#">📖 ConfigurationDesk I/O Function Implementation Guide</a> )
Injection Out	The Injection Out function block type lets you generate injection pulses for a real piston engine.	DS1554 (MicroAutoBox III)	<ul style="list-style-type: none"> <li>▪ Digital In/Out 8</li> <li>▪ Digital Out 7</li> </ul>	<a href="#">Injection Out</a> ( <a href="#">📖 ConfigurationDesk I/O Function Implementation Guide</a> )
Knock In	The Knock In function block lets you analyze the noise of a piston engine to avoid/minimize preignitions caused by improper ignition timing.	DS1554 (MicroAutoBox III)	Analog In 15	<a href="#">Knock In</a> ( <a href="#">📖 ConfigurationDesk I/O Function Implementation Guide</a> )
FuSa Setup	The FuSa Setup function block provides the basic functionality for implementing functional safety in your system. The function block triggers basic error responses and lets you enable additional error responses.	DS1403 (MicroAutoBox III)	FuSa Unit 1	<a href="#">FuSa Setup</a> ( <a href="#">📖 ConfigurationDesk I/O Function Implementation Guide</a> )
FuSa Response Trigger	Each FuSa Response Trigger function block works as a user-configurable software monitor to implement functional safety in your application. If you use this function block, a Functional Safety (FuSa) error can be triggered directly by software from within the behavior model.	DS1403 (MicroAutoBox III)	-	<a href="#">FuSa Response Trigger</a> ( <a href="#">📖 ConfigurationDesk I/O Function Implementation Guide</a> )
FuSa Challenge-Response Monitoring	Each FuSa Challenge-Response Monitoring function block works as a challenge-response monitor to support functional safety in your application. Based on the challenge and response principle, you can implement advanced monitoring services, for example, monitor periodic tasks or the correct execution of subsystems.	DS1403 (MicroAutoBox III)	FuSa Challenge-Response Unit 1	<a href="#">FuSa Challenge-Response Monitoring</a> ( <a href="#">📖 ConfigurationDesk I/O Function Implementation Guide</a> )

Function Block	Description	Supported Hardware	Channel Types	Further Information
PTP Master	The PTP Master function block provides a master time to which Ethernet devices can synchronize their clocks via a precision time protocol (PTP).	SCALEXIO: <ul style="list-style-type: none"> <li>SCALEXIO Processing Unit<sup>1)</sup></li> <li>DS6331-PE</li> <li>DS6333-CS</li> <li>DS6333-PE</li> </ul>		PTP Master ( <a href="#">ConfigurationDesk I/O Function Implementation Guide</a> )
PTP Slave	The PTP Slave function block provides time values to the behavior model that are synchronized via a precision time protocol (PTP) to an Ethernet time master.	<ul style="list-style-type: none"> <li>DS6334-PE</li> <li>DS6335-CS</li> </ul> MicroAutoBox III: <ul style="list-style-type: none"> <li>DS1403</li> <li>DS1521</li> </ul>		PTP Slave ( <a href="#">ConfigurationDesk I/O Function Implementation Guide</a> )
Domain Clock	The Domain Clock function block represents a domain clock. The base time can be set and is updated by the processing hardware.	-	-	Domain Clock ( <a href="#">ConfigurationDesk I/O Function Implementation Guide</a> )

<sup>1)</sup> As of Real-Time PC version 2.0 and Real-Time PC version HE 1.0. For identifying the version of the SCALEXIO Real-Time PC, refer to [Variants of the SCALEXIO Processing Unit](#) ([SCALEXIO Hardware Installation and Configuration](#)).

**New channel types for existing function block types**

The table below shows the function blocks that support new channel types:

Function Block	New Channel Types	Supported Hardware	Further Information
Voltage In	Analog In 17	DS1521 (MicroAutoBox III)	Voltage In ( <a href="#">ConfigurationDesk I/O Function Implementation Guide</a> )
Multi Bit In	Digital In/Out 10	DS1521 (MicroAutoBox III)	Multi Bit In ( <a href="#">ConfigurationDesk I/O Function Implementation Guide</a> )
Multi Bit Out	Digital In/Out 10	DS1521 (MicroAutoBox III)	Multi Bit Out ( <a href="#">ConfigurationDesk I/O Function Implementation Guide</a> )
PWM/PFM Out	Digital In/Out 10	DS1521 (MicroAutoBox III)	PWM/PFM Out ( <a href="#">ConfigurationDesk I/O Function Implementation Guide</a> )
PWM/PFM In	Digital In/Out 10	DS1521 (MicroAutoBox III)	PWM/PFM In ( <a href="#">ConfigurationDesk I/O Function Implementation Guide</a> )
Digital Pulse Capture	Digital In/Out 10	DS1521 (MicroAutoBox III)	Digital Pulse Capture ( <a href="#">ConfigurationDesk I/O Function Implementation Guide</a> )
Sine Encoder In	Analog In 16	DS6121 (SCALEXIO)	Sine Encoder In ( <a href="#">ConfigurationDesk I/O Function Implementation Guide</a> )
CAN	CAN 2	DS6342 (SCALEXIO)	CAN ( <a href="#">ConfigurationDesk I/O Function Implementation Guide</a> )
	CAN 6	DS1521 (MicroAutoBox III)	

Function Block	New Channel Types	Supported Hardware	Further Information
FlexRay	FlexRay 4	DS1521 (MicroAutoBox III)	<a href="#">FlexRay</a> ( <a href="#">📖 ConfigurationDesk I/O Function Implementation Guide</a> )
LIN	LIN 4	DS1521 (MicroAutoBox III)	<a href="#">LIN</a> ( <a href="#">📖 ConfigurationDesk I/O Function Implementation Guide</a> )
Ethernet Setup	Ethernet Adapter 3	DS1521 (MicroAutoBox III)	<a href="#">Ethernet Setup</a> ( <a href="#">📖 ConfigurationDesk I/O Function Implementation Guide</a> )

### New supported hardware

ConfigurationDesk supports the following new SCALEXIO hardware:

- DS6651 Multi I/O Module

The DS6651 Multi I/O Module is an I/O module for the FPGA base boards. It provides the channels for developing and testing a standard three-phase electric drive.

For more information, refer to [DS6651 Multi-I/O Module](#) ([📖 SCALEXIO Hardware Installation and Configuration](#)).

- DS6342 CAN Board

The DS6342 CAN Board provides 8 independent CAN/CAN FD channels with a software-configurable termination.

For more information, refer to [DS6342 CAN Board](#) ([📖 SCALEXIO Hardware Installation and Configuration](#)).

ConfigurationDesk supports the following new hardware components of the MicroAutoBox III:

- The new DS1521 Bus Board is a bus and network board that offers more automotive bus interfaces such as CAN FD and automotive Ethernet.

For more information, refer to [Features of the DS1521 Bus Board](#) ([📖 MicroAutoBox III Hardware Installation and Configuration](#)).

## New Features of the Bus Manager in ConfigurationDesk

### Enhanced J1939 support

**Support of J1939 transport protocols** The Bus Manager now supports the Broadcast Announce protocol and Connection Mode Data Transfer protocol.

If you use a DBC file as a communication matrix that sets up J1939 communication by using transport protocols, you can work with J1939-compliant ISignal IPDUs with up to 1,785 data bytes in bus configurations.

**Support of static network management according to J1939-81** The Bus Manger now supports static network management according to J1939-81. For this purpose, a new J1939 Network Management Enable bus configuration feature is available. When you add the feature to a communication controller, the related J1939 network node can send and respond to received address

claims. In case of an address conflict, the network node stops its J1939 communication if it cannot claim the requested address due to its priority.

For more information, refer to [Aspects of Supported CAN Bus Features](#) ([📖 ConfigurationDesk Bus Manager Implementation Guide](#)).

### Filtering CAN frame gateways

The Bus Manager now lets you filter CAN frames for gatewaying. For each communication cluster of a Frame Gateway, you can specify filter rules and specify whether the frames that pass the filter rules are included or excluded from being gatewayed.

For more information, refer to [Specifying Gateway Filters](#) ([📖 ConfigurationDesk Bus Manager Implementation Guide](#)).

### Enhanced bus configuration features

**PDU Raw Data feature** You can now add the PDU Raw Data feature to any RX and TX PDU that is assigned to the Simulated ECUs or Inspection part of a bus configuration. By default, this lets you read the payload of the RX or TX PDU in raw data format, and access the data via experiment software. Depending on the PDU type of TX PDUs, you can additionally switch the access mode to write raw data to the payload of TX PDUs.

For more information, refer to [Accessing the Payload of PDUs in Raw Data Format](#) ([📖 ConfigurationDesk Bus Manager Implementation Guide](#)).

**PDU User Code feature** The PDU User Code feature is now also available as a bus manipulation feature.

For more information, refer to [Applying User Code to PDUs](#) ([📖 ConfigurationDesk Bus Manager Implementation Guide](#)).

**Bus manipulation features that affect secure onboard communication** For bus manipulation features that affect secure onboard communication (SecOC), you can now recalculate the authentication information of the related secured IPDUs. When you do this, you can prevent the bus manipulation features from unintentionally invalidating the authentication information.

For more information, refer to [Basics on Bus Manipulation Features](#) ([📖 ConfigurationDesk Bus Manager Implementation Guide](#)).

### Enhanced support of CAN and LIN communication

The Bus Manager now provides the following enhancements for CAN and/or LIN communication:

- Support of array signals of UInt8 data type and opaque byte order
- Support of the following AUTOSAR-compliant triggering options for container IPDUs with static container layout:
  - Container timeout
  - Container IPDU trigger mode
  - PDU collection trigger mode



- Support of CAN PDUs for which the communication matrix does not specify a sending or receiving ECU. If you add such a communication matrix to the ConfigurationDesk application, a `DS_UnknownSender` or `DS_UnknownReceiver` ECU is generated during the import process and the affected PDUs are assigned to the related ECU.

---

### Generating bus simulation containers for offline simulation applications on Linux

The Bus Manager now lets you generate bus simulation containers (BSC files) that can be used in offline simulation applications that are built for execution on a Linux operating system. For this purpose, you do not have to make any manual configurations. Instead, you only have to include 64-bit Simulink implementation containers (SIC files) in the bus simulation containers.

---

### Basic ARXML communication matrix

The Bus Manager now provides a basic communication matrix, which is an AUTOSAR system description file (ARXML file). You can use this file as a starting point to set up simple CAN communication. For this purpose, you can modify the file in the ConfigurationDesk application, and assign elements to bus configurations.

For more information, refer to [Basics on Modifying Communication Matrices](#) ( [ConfigurationDesk Bus Manager Implementation Guide](#)).

---

### Bus Manager tutorial

The Bus Manager now provides a Bus Manager tutorial. The tutorial guides you through the basic steps when you start working with the Bus Manager, and covers typical use scenarios. For more information, refer to  [Bus Manager Tutorial](#).

## Supported Container File Versions

---

### Supported SIC file versions

ConfigurationDesk 6.5 supports SIC file versions as listed below:

SIC Files Created With ...	SIC Version
dSPACE Release 2020-A: <ul style="list-style-type: none"> <li>▪ Model Interface Package for Simulink 4.3</li> </ul>	1.8
dSPACE Release 2019-B: <ul style="list-style-type: none"> <li>▪ Model Interface Package for Simulink 4.2</li> <li>▪ TargetLink 5.0</li> </ul>	1.7
dSPACE Release 2019-A: <ul style="list-style-type: none"> <li>▪ Model Interface Package for Simulink 4.1</li> </ul>	1.6
dSPACE Release 2018-B: <ul style="list-style-type: none"> <li>▪ Model Interface Package for Simulink 4.0</li> <li>▪ TargetLink 4.4</li> </ul>	1.5

**Note**

- Real-time applications containing SIC files that were generated with TargetLink 4.4 cannot be used on a MicroAutoBox III.
- You can use only SIC files that were generated with the Model Interface Package for Simulink for the `dsrt.tlc` system target file for building real-time applications with ConfigurationDesk. SIC files generated for the `dsrt64.tlc` system target file can only be used in ConfigurationDesk to generate BSC files for VEOS running on a Linux operating system.

**Supported BSC file versions**

ConfigurationDesk 6.5 supports BSC files of version 1.8.

**Supported V-ECU implementation container versions**

ConfigurationDesk 6.5 supports V-ECU implementation container versions as listed below:

V-ECU Implementations Created With...	V-ECU Implementation Version
dSPACE Release 2020-A: <ul style="list-style-type: none"> <li>▪ SystemDesk 5.4</li> </ul>	2.10 <sup>1)</sup>
dSPACE Release 2019-B: <ul style="list-style-type: none"> <li>▪ SystemDesk 5.4</li> <li>▪ TargetLink 5.0</li> </ul>	2.10 <sup>1)</sup>
dSPACE Release 2019-A: <ul style="list-style-type: none"> <li>▪ SystemDesk 5.3</li> </ul>	2.9 <sup>2)</sup>
dSPACE Release 2018-B: <ul style="list-style-type: none"> <li>▪ SystemDesk 5.2</li> <li>▪ TargetLink 4.4</li> </ul>	2.8 <sup>2)</sup>

<sup>1)</sup> You can integrate a CTLGZ file of this version in a VEOS simulation on Windows and in a VEOS simulation on Linux.

<sup>2)</sup> You can integrate a CTLGZ file of this version in a VEOS simulation on Windows, not in a VEOS simulation on Linux.

**Supported Functional Mock-up Unit versions**

ConfigurationDesk 6.5 supports Functional Mock-up Units (FMUs) that comply with the following versions of the FMI standard:

- 2.0
- 2.0.1

**Supported EIC file versions**

ConfigurationDesk 6.5 supports EIC file versions as listed below:

EIC Files Created With ...	EIC Version
dSPACE Release 2020-A (ECU Interface Manager 2.7)	4.0.0
dSPACE Release 2019-B (ECU Interface Manager 2.6)	4.0.0

EIC Files Created With ...	EIC Version
dSPACE Release 2019-A (ECU Interface Manager 2.5)	3.0.0
dSPACE Release 2018-B (ECU Interface Manager 2.4)	3.0.0
dSPACE Release 2018-A (ECU Interface Manager 2.3)	2.0.0
dSPACE Release 2017-B (ECU Interface Manager 2.2)	1.0.0
dSPACE Release 2017-A (ECU Interface Manager 2.1)	1.0.0
dSPACE Release 2016-B (ECU Interface Manager 2.0p1)	1.0.0

However, MicroAutoBox III systems only support EIC files as of version 4.0.0.

## Migrating to ConfigurationDesk 6.5

### Discontinuation of SCALEXIO Ethernet Solution

The SCALEXIO Ethernet Solution is discontinued as follows:

- The end-of-life date is January 31, 2021. You can still buy the product up to and including January 31, 2019.
- New Releases of the SCALEXIO Ethernet Solution will still be available for customers with a Software Maintenance Service contract until at least January 31, 2020.
- Customers with a Software Maintenance Service contract who work with dSPACE Release 2018-B will be automatically migrated to the new ConfigurationDesk UDP/TCP function blocks.

For new projects (using dSPACE Release 2018-A and later), we recommend that you use the new UDP/TCP function blocks that are natively integrated in ConfigurationDesk. They provide additional and new options such as IPv6, UDP Multicast support, and enhanced TCP status information.

Note: The dedicated license is required for using the new UDP/TCP function blocks in ConfigurationDesk.

### FPGA custom function blocks with APU functionality

With dSPACE Release 2018-B, the angle range handling of the angular processing unit (APU) changed. FPGA custom function blocks that use the APU in the 360° angle range are incompatible if they are built with the FPGA Programming Blockset 3.5 or earlier.

To resolve the incompatibility, use the FPGA model/code of the incompatible FPGA custom function block and build a new FPGA custom function block with the RTI FPGA Programming Blockset 3.6 or later. The RTI FPGA Programming

Blockset automatically migrates the framework of the FPGA model/code to the current version.

---

**Changes to the tool automation interface that might lead to code malfunctions**

The automation names of some function block properties were changed. You must adjust the automation names of these properties in existing scripts for them to work correctly. For more information, refer to [New Features and Changes to the Automation Interface for Release 2020-A](#) ( [ConfigurationDesk Automating Tool Handling](#)).

# ControlDesk

---

**Where to go from here**

**Information in this section**

New Features of ControlDesk 7.2.....	70
Migrating to ControlDesk 7.2.....	77

## New Features of ControlDesk 7.2

### Where to go from here

### Information in this section

<a href="#">New Features of Platform Management and Platforms/Devices (ControlDesk 7.2)</a> .....	70
Gives an overview of new features of platform management and platforms/devices in ControlDesk 7.2.	
<a href="#">New Layouting Features (ControlDesk 7.2)</a> .....	71
Gives an overview of the new layouting features as of ControlDesk 7.2.	
<a href="#">New Instrument Features (ControlDesk 7.2)</a> .....	72
Gives an overview of the new instrument features in ControlDesk 7.2.	
<a href="#">New Measurement and Recording Features (ControlDesk 7.2)</a> .....	73
Gives an overview of the new measurement and recording features in ControlDesk 7.2.	
<a href="#">New Bus Navigator Features (ControlDesk 7.2)</a> .....	74
Gives an overview of the new Bus Navigator features in ControlDesk 7.2.	
<a href="#">Additional Enhancements and Changes with ControlDesk (ControlDesk 7.2)</a> .....	76
Gives an overview of additional enhancements as of ControlDesk 7.2.	

## New Features of Platform Management and Platforms/Devices (ControlDesk 7.2)

### MicroAutoBox III: Support of the DS1521 Bus Board

ControlDesk now supports MicroAutoBox III systems with the DS1521 Bus Board.

### MicroAutoBox III: Support of CAN, Ethernet, and LIN bus channels

You can now also use CAN, Ethernet, and LIN bus channels of the MicroAutoBox III with bus monitoring devices.

Refer to [Supported Interfaces for Accessing a Communication Bus](#) ( [ControlDesk Platform Management](#)).

### MicroAutoBox III: Support of inheritance

The MicroAutoBox III now also supports inheritance settings.

Refer to [Inheritance Settings Properties](#) ( [ControlDesk Platform Management](#)).

---

**SCALEXIO: Support of the DS6342 CAN Board and the DS6651 Multi-I/O Module**

ControlDesk now supports the following new SCALEXIO boards/modules:

- DS6342 CAN Board
  - DS6651 Multi-I/O Module
- 

**MicroAutoBox III, SCALEXIO: Ethernet switch configuration**

ControlDesk now lets you specify and manage the Ethernet switch and physical layer configuration of:

- ETH/AETH ports of a MicroAutoBox III
- DS6333-PE Automotive Ethernet Boards, DS6333-CS Automotive Ethernet Boards, or DS6335-CS Ethernet Boards that are installed in a SCALEXIO system

Refer to [Ethernet Switch Configuration](#) ( [ControlDesk Platform Management](#)).

---

**dSPACE real-time hardware: Display of the operating system**

ControlDesk now displays the operating system of dSPACE real-time hardware.

Refer to [Software Properties](#) ( [ControlDesk Platform Management](#)).

---

**dSPACE real-time hardware: Display of the path to the flash application**

ControlDesk now displays the path to the flash application currently loaded to the selected dSPACE real-time hardware.

Refer to [Flash Application Path Property](#) ( [ControlDesk Platform Management](#)).

---

**Starting the active dSPACE ECU Flash Programming Tool**

If you start the dSPACE ECU Flash Programming Tool from ControlDesk, the active installation with the highest version number is started.

Refer to [New Features of the dSPACE ECU Flash Programming Tool 2.7](#) on page 83.

---

## New Layouting Features (ControlDesk 7.2)

---

**Specifying layout descriptions**

You can now specify a description for each layout.

Refer to [Layout Properties](#) ( [ControlDesk Layouting](#)).

## New Instrument Features (ControlDesk 7.2)

### Display, Numeric Input, Variable Array: Support of 64-bit integer variables

The following ControlDesk instruments now support 64-bit integer variables (int64 and uint64) in source mode:

- Display (read)
- Numeric Input (read and write)
- Variable Array (read and write)

### 3-D Viewer: Displaying surfaces

The 3-D Viewer introduced with ControlDesk 7.1 has been improved: You can now display shapes in the 3-D Viewer by using the new *surface* item type. This lets you display a road surface or the height profile of a landscape, for example.

You can also display the values of one or more variables as a three-dimensional chart, as shown in the following illustration:

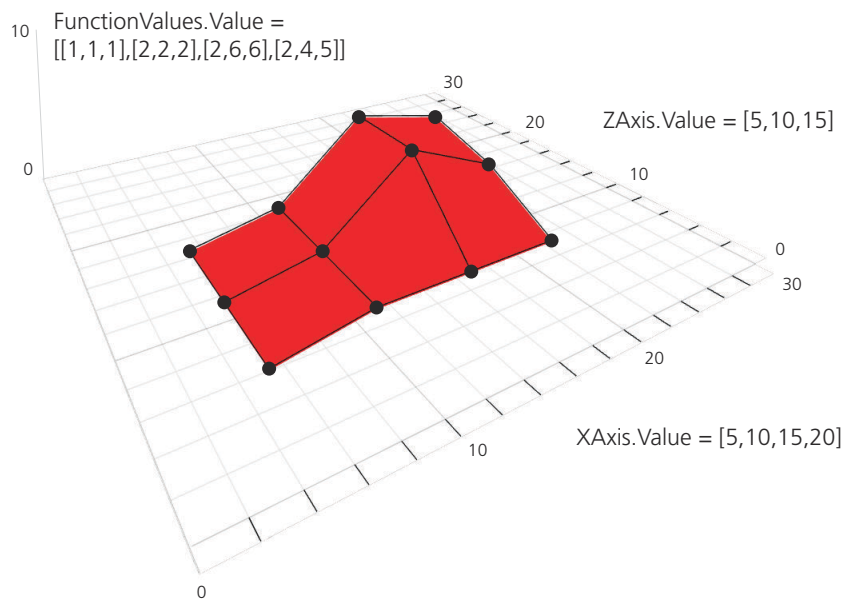

For more information, refer to [Basics of Surfaces](#) ( [ControlDesk Instrument Handling](#)).

### 3-D Viewer: Specifying the pattern of point lines

You can now specify the pattern of point lines in the 3-D Viewer. This lets you create a more realistic visualization of road markings, for example.



The following illustration shows some point lines with different pattern styles as an example.

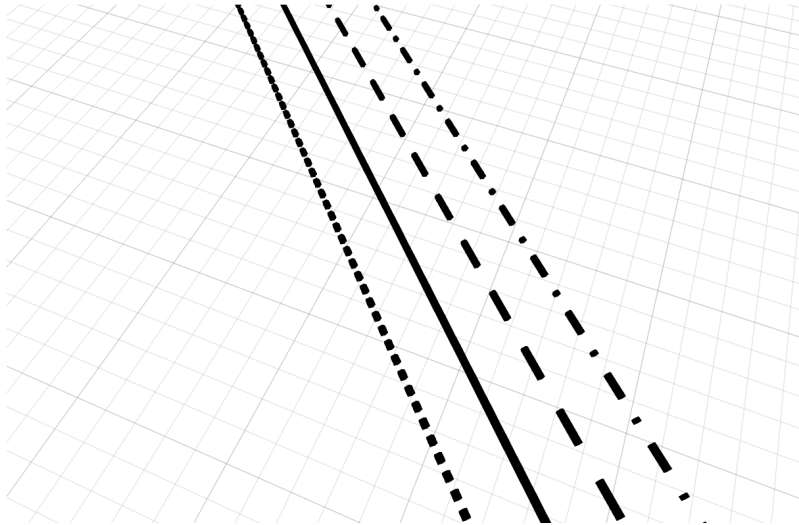

For more information, refer to [Items and Templates Properties](#) ( [ControlDesk Instrument Handling](#)).

## New Measurement and Recording Features (ControlDesk 7.2)

### **Configuring data logging on a MicroAutoBox III**

ControlDesk now lets you configure data logging on a MicroAutoBox III to perform data recording without connection to a host PC. The logged data is stored on a USB mass storage device connected to the MicroAutoBox III in the ASAM MDF (MF4) file format.

You configure data logging in the Measurement Configuration controlbar in a similar way as you configure measurements or recordings.

You can define various data loggers for a MicroAutoBox III platform. The following illustration shows an example.

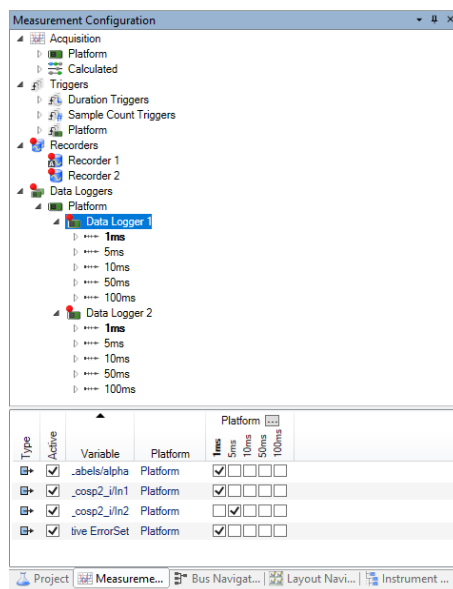

After you have loaded a real-time application and a related data logger configuration to the MicroAutoBox III flash memory, you can perform data logging independently of ControlDesk and the host PC.

Refer to [General Information on Data Logging](#) ([ControlDesk Measurement and Recording](#)).

## New Bus Navigator Features (ControlDesk 7.2)

### Improved replay of logged CAN data

You can now use bus interfaces of MicroAutoBox III, SCALEXIO, and VEOS in connection with the CAN Bus Monitoring device for replaying logged CAN bus communication.

For more information, refer to [Basics on Replaying CAN Bus Communication](#) ([ControlDesk Bus Navigator](#)).

### Bus monitoring devices: support of MicroAutoBox III bus interfaces

You can now use the bus interfaces of the MicroAutoBox III in connection with bus monitoring devices for monitoring, logging, and replaying (depending on the bus type).

For more information, refer to [Overview of Monitoring, Logging, and Filtering Bus Communication](#) ([ControlDesk Bus Navigator](#)) and [Basics on Replaying CAN Bus Communication](#) ([ControlDesk Bus Navigator](#)).

### Creating FlexRay Bus instruments via tool automation

For applications configured with the dSPACE FlexRay Configuration Package, you can now also create FlexRay Bus instruments via tool automation.

Refer to [FlexRayBusSystem / IBnFlexRayBusSystem <<Interface>>](#) ( [ControlDesk Automation](#)).

### Displaying Ethernet socket hierarchy

The Bus Navigator tree now provides two configurations for displaying the Ethernet communication between the ECUs that you can select via the Show Socket Hierarchy () button. The socket hierarchy display is disabled by default.

The ControlDesk Variables controlbar now also displays the Ethernet socket hierarchy.

Refer to [Basics on Ethernet PDUs in the Bus Navigator](#) ( [ControlDesk Bus Navigator](#)).

### GTS source switch in bus instruments

For CAN bus communication with Global Time Synchronization signals that was modeled with the RTI CAN MultiMessage Blockset, you can now select GTS as the signal source in the bus instrument.

Refer to [Bus Instrument \(TX Type for CAN\)](#) ( [ControlDesk Bus Navigator](#)).

### Easier access to the definition, export, and import of Ethernet filters



You can now access the Manage Capture Filter Expressions dialog, which lets you define, export, and import user-defined Ethernet filters, more easily. The dialog is now also accessible from the Bus Navigator page of the ControlDesk Options dialog.

Refer to [Bus Navigator Page](#) ( [ControlDesk Bus Navigator](#)).

### Bus Instruments: Status display

For applications configured with the Bus Manager, Bus Instruments for single PDUs now provide the PDU State instrument region. Depending on the settings specified in the Bus Manager, the region displays the status of the entire bus configuration, the communication controller, and the PDU.

The following illustration shows the new PDU State region for the Bus Instrument (RX Type for CAN) as an example:

PDU State	
Bus Configuration Enable	
Communication Controller Enable Access	
PDU Enable Access	

For more information, refer to [Bus Instruments \(Bus Manager\)](#) ( [ControlDesk Bus Navigator](#)).

## Additional Enhancements and Changes with ControlDesk (ControlDesk 7.2)

---

**Project conversion  
information in dSPACE Log**

Information on automatic project conversion now is logged to the dSPACE Log.

For more information, refer to [dSPACE Log](#) ( [ControlDesk Message Handling](#)).

# Migrating to ControlDesk 7.2

## Where to go from here

## Information in this section

<a href="#">Discontinuations in ControlDesk.....</a>	<a href="#">77</a>
Gives you an overview of the discontinuations in ControlDesk.	
<a href="#">Migrating to ControlDesk 7.2.....</a>	<a href="#">78</a>
To migrate from ControlDesk 7.1 to ControlDesk 7.2 and reuse existing experiments, you might have to carry out the following migration steps.	

## Discontinuations in ControlDesk

### Discontinuations as of ControlDesk 7.2

**IDF file import** As of ControlDesk 7.2, importing files in the IDF format is no longer supported.

There is a migration issue in connection with the Measurement Data API. Refer to [Measurement Data API changes](#) on page 80.

Use the ASAM MDF 4.1 file format (file name extension: MF4), which is the standard ControlDesk file format for measurement data files.

**DS1005 PPC Board platform** As of ControlDesk 7.2, the DS1005 PPC Board platform is no longer available, and the DS1005 is no longer supported.

For new projects, you are recommended to use the DS1007 PPC Processor Board.

For migration aspects, refer to [Experiments containing a platform based on the DS1005](#) on page 78.

**DCI-GSI1 device** As of ControlDesk 7.2, the DCI-GSI1 device is no longer available, and the DCI-GSI1 is no longer supported.

For new projects, you are recommended to use the DCI-GSI2.

For migration aspects, refer to [Experiments containing a DCI-GSI1 device](#) on page 78.

**Support for DCI-CAN1** As of ControlDesk 7.2, the DCI-CAN1 is no longer supported.

For new projects, you are recommended to use the DCI-CAN2 or DCI-CAN/LIN1.

**Support for MicroAutoBox II with DS1512** As of ControlDesk 7.2, the MicroAutoBox II variants 1401/1511/1512 and DS1401/1512/1513 are no longer supported.

For new projects, you are recommended to use the MicroAutoBox II or MicroAutoBox III variants with a DS1514 I/O Board.

**Global data sets** As of ControlDesk 7.2, global data sets are no longer supported, i.e., you can no longer make a data set available to all the experiments of the current ControlDesk project.

During project migration, global data sets are removed from the project.

**Adding version control to projects from within ControlDesk** As of ControlDesk 7.2, you can no longer add version control to projects from within ControlDesk, i.e., ControlDesk no longer provides the relevant commands.

---

### End of software support for discontinued dSPACE hardware

For information on the end of software support for discontinued dSPACE hardware, refer to [Discontinuations](#) on page 14.

## Migrating to ControlDesk 7.2

---

### Introduction

To migrate from ControlDesk 7.1 to ControlDesk 7.2 and reuse existing experiments, you might have to carry out the following migration steps.

#### Note

To migrate to ControlDesk 7.2 from versions earlier than 7.1, you might also have to perform the migration steps of the intervening ControlDesk versions.

---

### Experiments containing a platform based on the DS1005

When you open an experiment with one of the following platforms in ControlDesk 7.2 or later, a message is displayed in the dSPACE Log, and the platform is removed from the experiment.

- DS1005 PPC Board platform
- Multiprocessor System platform based on the DS1005

This is due to the [Discontinuations as of ControlDesk 7.2](#) ([📖 ControlDesk Introduction and Overview](#)).

However, you can reuse experiment parts if you use newer dSPACE real-time hardware, such as the DS1007 PPC Processor Board, which is the successor of the DS1005 PPC Board.

For more information, refer to [Switching the Simulation Platform and Reusing Experiment Parts](#) ([📖 ControlDesk Platform Management](#)).

---

### Experiments containing a DCI-GSI1 device

When you open an experiment with a DCI-GSI1 device in ControlDesk 7.2 or later, a message is displayed in the dSPACE Log, and the device is removed from the experiment.

This is due to the discontinuation of the DCI-GSI1 device (refer to [Discontinuations as of ControlDesk 7.2](#) ([📖 ControlDesk Introduction and Overview](#))).

If the variable description assigned to the device is not used in another experiment, remove it from the project.

### Migrating dSPACE EESPort configuration files

As of dSPACE Release 2020-A, the DCI-CAN1 and the dSPACE CAN API 1.0 are no longer supported. As a result, ControlDesk no longer supports dSPACE EESPort configuration files that reference either the DCI-CAN1 or the dSPACE CAN API 1.0, or both.

- Instead of the DCI-CAN1, use the DCI-CAN2 or the DCI-CAN/LIN1.
- Instead of the dSPACE CAN API 1.0, use the dSPACE CAN API 2.0.

The following listing is an excerpt of a dSPACE EESPort configuration file that references both the dSPACE CAN API 1.0 and the DCI-CAN1:

```
<Driver ID="2" DriverType="DSCanApi1.0">
  <InterfaceType>dSPACE CAN Interface</InterfaceType>
  <CardIndex>15</CardIndex>
  <ControllerIndex>1</ControllerIndex>
  <SerialNumber>0</SerialNumber>
</Driver>
```

The following listing shows how to migrate the excerpt above:

```
<Driver ID="2" DriverType="DSCanApi2.0">
  <VendorName>dSPACE</VendorName>
  <InterfaceName>DCI-CAN2</InterfaceName>
  <ChannelIdentifier>1</ChannelIdentifier>
  <SerialNumber>0</SerialNumber>
</Driver>
```

The migrated listing references the dSPACE CAN API 2.0 and the DCI-CAN2.

### Tool automation changes

**Discontinued interfaces** The following features and components have been discontinued in ControlDesk 7.2:

- DS1005 PPC Board platform
  - DCI-GSI1 device
  - DCI-CAN1 device
  - Support for MicroAutoBox II with DS1512
  - IDF file import
  - Global data sets
  - Adding version control to projects from within ControlDesk
- As a consequence, the related automation interfaces, properties, and methods have also been discontinued in ControlDesk 7.2. For a complete list, refer to [Automation Interfaces Discontinued in ControlDesk 7.2](#) ( [ControlDesk Automation](#)).

### Measurement Data API changes

As of ControlDesk 7.2, the following interfaces and constants are no longer available:

- `DelayedLoadingOption` interface
- `FileLoadingSchemeConstants` constant

This is due to the discontinuation of the IDF file import.

If you also used the `DelayedLoadingOption` interface to specify the `fileComplete` file loading scheme for loading or unloading MF4 files, you can use the `LoadData (Signals)` or `UnloadData (Signals)` methods as an alternative.

---

### Migrating from earlier ControlDesk versions

To migrate from earlier ControlDesk versions and reuse existing experiments, you might have to carry out additional migration steps. For more information on the migration steps, refer to [Migrating from Prior Versions of ControlDesk](#) ([📖 ControlDesk Introduction and Overview](#)).

---

### Related topics

#### Basics

[Basics on Migrating from Prior Versions of ControlDesk](#) ([📖 ControlDesk Introduction and Overview](#))



# DCI Configuration Tool

## Where to go from here

## Information in this section

New Features of the DCI Configuration Tool 3.12.....	81
Migrating to DCI Configuration Tool 3.12.....	82

## New Features of the DCI Configuration Tool 3.12

### Support of DCI-GSI2s with microcontrollers with JTAG/ARM target interface

The DCI Configuration Tool now also supports device configurations for DCI-GSI2s that are equipped with a processor with a JTAG/ARM target interface.

This currently applies to the following target processor families:

- Cypress MB9D560
- Texas Instruments TMS570
- Toshiba TMPV770

Refer to [Target Interface Page](#) ( [DCI Configuration](#)).

### Firmware version for DCI-GSI2 interfaces

For the DCI-GSI2 interfaces, the firmware version 1.5.0 is delivered with the DCI Configuration Tool 3.12.

#### Note

The firmware version delivered with the DCI Configuration Tool is not always the latest firmware version available. If you encounter any problems, contact dSPACE Support to check if a later firmware version is available.

# Migrating to DCI Configuration Tool 3.12

**Discontinuation of DCI-GSI1 support**

As of DCI Configuration Tool 3.12, the configuration of a DCI-GSI1 is no longer supported.

# dSPACE ECU Flash Programming Tool

## Where to go from here

## Information in this section

New Features of the dSPACE ECU Flash Programming Tool 2.7..... 83

Discontinuations in the dSPACE ECU Flash Programming Tool..... 83

## New Features of the dSPACE ECU Flash Programming Tool 2.7

### Tool installation

As of dSPACE ECU Flash Programming Tool 2.7, you can install several tool versions in any folders on the host PC. Previously, only one tool installation was supported. One of the tool installations is the *active installation*. Usually, the last installation of the dSPACE ECU Flash Programming Tool on the host PC automatically becomes the active installation. However, you can activate a particular installation (as of Ver. 2.7) manually in the dSPACE Installation Manager. Any tool version that is installed on the host PC and older than dSPACE ECU Flash Programming Tool 2.7 cannot be deactivated in the dSPACE Installation Manager, but is always active.

If you start the dSPACE ECU Flash Programming Tool from ControlDesk, the active installation with the highest version number is started.

## Discontinuations in the dSPACE ECU Flash Programming Tool

### Discontinuations as of dSPACE ECU Flash Programming Tool 2.7

**DCI-GME1 and DCI-GSI1 support** The dSPACE ECU Flash Programming Tool no longer supports flash programming on an ECU with DCI-GME1 or DCI-GSI1.

For a list of the ECU interface types supported by the dSPACE ECU Flash Programming Tool, refer to [Supported ECU Interface Types](#) ( [ECU Flash Programming](#)).

**DCI-CAN1 support** ECU flash programming via the dSPACE ECU Flash Programming Tool requires a connection between the ECU and the host PC. For ECUs with XCP on CAN, the dSPACE ECU Flash Programming Tool no longer supports the DCI-CAN1 as a CAN interface.

For a list of the CAN interfaces supported by the dSPACE ECU Flash Programming Tool, refer to [Supported ECU Interface Types](#) ( [ECU Flash Programming](#)).

# dSPACE FlexRay Configuration Package

## Where to go from here

## Information in this section

[New Features of dSPACE FlexRay Configuration Package 4.5..... 85](#)

[Migrating to dSPACE FlexRay Configuration Package 4.5..... 86](#)

## New Features of dSPACE FlexRay Configuration Package 4.5

### FlexRay Configuration Package

**New supported platform** The FlexRay Configuration Package supports MicroAutoBox III systems with a DS1521 Bus Board. The DS1521 Bus Board provides two FlexRay communication controllers of the FlexRay 4 channel type. Each controller provides a FlexRay channel A and a FlexRay channel B.

**Support of BITFIELD-TEXTTABLE computation method** The FlexRay Configuration Tool now also supports the BITFIELD-TEXTTABLE computation method. The BITFIELD-TEXTTABLE computation method results in a concatenated value set.

**RX time stamps** The FlexRay Configuration Package provides RX time stamp information for an IPDU, which indicates the time when the corresponding LPDU was received via the FlexRay bus:

- **RX Timestamps** entries can be included in the TRC file. To do so, you must select the **Frame Receive Status Access** feature in the **Element Selection** dialog.
- The **FLEXRAYCONFIG PDU RX** block is extended. The PDU RX mapping subsystem contains the **RX Timestamp** output to display the time at which an LPDU was received.

Refer to [FLEXRAYCONFIG PDU RX Mapping Subsystems](#) ( [FlexRay Configuration Blockset Reference](#)).

The RX time stamp feature is available for SCALEXIO systems.

## Migrating to dSPACE FlexRay Configuration Package 4.5

---

### **Discontinued support for dSPACE hardware**

As of dSPACE FlexRay Configuration Package 4.5, software support is discontinued for the following dSPACE hardware:

- DS1005 PPC Board
- MicroAutoBox II variants with the DS1512 I/O Board

# dSPACE Installation Manager

## Where to go from here

## Information in this section

[New Features of dSPACE Installation Manager 5.5](#)..... 87

[Migrating to dSPACE Installation Manager 5.5](#)..... 87

## New Features of dSPACE Installation Manager 5.5

### New features for managing licenses

**Renew borrowed licenses** Now you can renew borrowed licenses to extend the borrow period before it expires. Refer to [How to Renew Borrowed Licenses](#) ([Working with CodeMeter Licensing Technology](#)).

**Alerts for expiring licenses** dSPACE Installation Manager now uses alerts to notify you before a license expires. Refer to [Alerts for Expiring Licenses](#) ([Working with CodeMeter Licensing Technology](#)).

## Migrating to dSPACE Installation Manager 5.5

### Using CmDongles

If you want to work with licenses on CmDongles in combination with dSPACE Installation Manager 5.5, for example, to activate, deactivate, or update licenses, the dongles must have firmware version 4.10.

To use CmDongles shipped for Releases earlier than dSPACE Release 2019-A, a firmware update is required. CmDongles shipped for dSPACE Release 2019-A and later contain the required firmware version.

dSPACE Installation Manager checks if the firmware of a connected dongle matches the required firmware version and displays if an update is necessary.

For instructions on updating the firmware, refer to [How to Update the Firmware of a CmDongle](#) ([📖 Working with CodeMeter Licensing Technology](#)).



# dSPACE XIL API .NET

## Where to go from here

## Information in this section

New Features of dSPACE XIL API .NET 2020-A.....	89
Migrating to dSPACE XIL API .NET 2020-A.....	89

## New Features of dSPACE XIL API .NET 2020-A

### New features

The dSPACE XIL API.NET 2020-A does not have new features. However, note the discontinued platform support for the DS1005 PPC Board and the DCI-CAN1 device.

For information on the Python and XIL API support changed with dSPACE Release 2018-B, refer to <http://www.dspace.com/go/Python36Migration> and the *New Features and Migration* document from dSPACE Release 2018-B.

## Migrating to dSPACE XIL API .NET 2020-A

### Migrating dSPACE EESPort configuration files

As of dSPACE Release 2020-A, the DCI-CAN1 and the dSPACE CAN API 1.0 are no longer supported. As a result, dSPACE XIL API .NET no longer supports dSPACE EESPort configuration files that reference either the DCI-CAN1 or the dSPACE CAN API 1.0, or both.

- Instead of the DCI-CAN1, use the DCI-CAN2 or the DCI-CAN/LIN1.
- Instead of the dSPACE CAN API 1.0, use the dSPACE CAN API 2.0.

The following listing is an excerpt of a dSPACE EESPort configuration file that references both the dSPACE CAN API 1.0 and the DCI-CAN1:

```
<Driver ID="2" DriverType="DSCanApi1.0">  
  <InterfaceType>dSPACE CAN Interface</InterfaceType>  
  <CardIndex>15</CardIndex>  
  <ControllerIndex>1</ControllerIndex>  
  <SerialNumber>0</SerialNumber>  
</Driver>
```

The following listing shows how to migrate the excerpt above:

```
<Driver ID="2" DriverType="DSCanApi2.0">  
  <VendorName>dSPACE</VendorName>  
  <InterfaceName>DCI-CAN2</InterfaceName>  
  <ChannelIdentifier>1</ChannelIdentifier>  
  <SerialNumber>0</SerialNumber>  
</Driver>
```

The migrated listing references the dSPACE CAN API 2.0 and the DCI-CAN2.

# ECU Interface Manager

## Where to go from here

## Information in this section





<a href="#">New Features of ECU Interface Manager 2.7</a> .....	91
An overview of the new features of ECU Interface Manager 2.7.	
<a href="#">Compatibility of ECU Interface Manager 2.7</a> .....	92
Provides information on the compatibility of ECU Interface Manager 2.7.	
<a href="#">Migrating to ECU Interface Manager 2.7</a> .....	92
Information on how to migrate to ECU Interface Manager 2.7.	

## New Features of ECU Interface Manager 2.7

### ARM Cortex-R4/R5 microcontroller support

The ECU Interface Manager now supports the ARM Cortex-R4/R5 microcontroller family.

You can now modify the binary code of ARM Cortex-R4/R5 applications, including:

- Integration of dSPACE ECU services into the binary code for external ECU interfacing and on-target ECU interfacing.  
For more information, refer to [Basics on the ECU Interface Manager](#) ( [ECU Interface Manager Manual](#)).
- Integration of ECU service calls into the binary code.  
For more information, refer to [Basics on the ECU Interface Manager](#) ( [ECU Interface Manager Manual](#)).
- Disabling the execution of code items, such as write accesses.  
For more information, refer to [Disabling the Execution of Code Items](#) ( [ECU Interface Manager Manual](#)).
- Deleting functions to free flash memory.  
For more information, refer to [Delete](#) ( [ECU Interface Manager Manual](#)).

## Compatibility of ECU Interface Manager 2.7

### Compatibility in general

dSPACE recommends using only software products from the same dSPACE Release. This ensures maximum run-time compatibility.

### Compatibility between EIC files and ConfigurationDesk

The following table shows the compatibility between EIC files and ConfigurationDesk:

	EIC Files Created with ECU Interface Manager ...							
	Version 2.0p1 <sup>1), 2)</sup>	Version 2.1 <sup>3), 2)</sup>	Version 2.2 <sup>4), 2)</sup>	Version 2.3 <sup>5), 2)</sup>	Version 2.4 <sup>6), 2)</sup>	Version 2.5 <sup>7), 2)</sup>	Version 2.6 <sup>8)</sup>	Version 2.7 <sup>9)</sup>
ConfigurationDesk 6.5 <sup>9)</sup>	✓	✓	✓	✓	✓	✓	✓	✓
ConfigurationDesk 6.4 <sup>8)</sup>	✓	✓	✓	✓	✓	✓	✓	—
ConfigurationDesk 6.3 <sup>7)</sup>	✓	✓	✓	✓	✓	✓	—	—
ConfigurationDesk 6.2 <sup>6)</sup>	✓	✓	✓	✓	✓	—	—	—
ConfigurationDesk 6.1 <sup>5)</sup>	✓	✓	✓	✓	—	—	—	—
ConfigurationDesk 6.0 <sup>4)</sup>	✓	✓	✓	—	—	—	—	—
ConfigurationDesk 5.7 <sup>3)</sup>	✓	✓	—	—	—	—	—	—
ConfigurationDesk 5.6 SP1 <sup>1)</sup>	✓	✓	—	—	—	—	—	—

<sup>1)</sup> dSPACE Release 2016-B

<sup>2)</sup> To perform external ECU interfacing with MicroAutoBox III, the EIC file must be created with ECU Interface Manager 2.6 or later. EIC files created with ECU Interface Manager 2.5 or earlier are not supported.

<sup>3)</sup> dSPACE Release 2017-A

<sup>4)</sup> dSPACE Release 2017-B

<sup>5)</sup> dSPACE Release 2018-A

<sup>6)</sup> dSPACE Release 2018-B

<sup>7)</sup> dSPACE Release 2019-A

<sup>8)</sup> dSPACE Release 2019-B

<sup>9)</sup> dSPACE Release 2020-A

## Migrating to ECU Interface Manager 2.7

### Automatic migration of projects

You can reuse projects in ECU Interface Manager 2.7 if the projects were last saved with the ECU Interface Manager 2.0 p1 or later.

When you open the projects in the ECU Interface Manager 2.7, they are migrated automatically.

**Note**

In the ECU Interface Manager 2.7, you cannot reuse projects that were last saved with ECU Interface Manager 2.0 or earlier.

---

**Additional migration steps in some cases**

To migrate to the ECU Interface Manager 2.7 from versions earlier than the ECU Interface Manager 2.2, you might also have to perform the migration steps of the intervening ECU Interface Manager versions.



# Firmware Manager

## New Features of Firmware Manager 3.1

---

### **Enhanced platform support**

The Firmware Manager supports the firmware update of the following dSPACE hardware:

- DS1521 Bus Board for MicroAutoBox III
- DS6342 CAN Board
- DS6651 Multi-I/O Module

### **Discontinued platforms**

The Firmware Manager no longer supports the firmware update for the discontinued DS1005 PPC Board. The Firmware Archives setup no longer contains a firmware archive for the DS1005.





# MicroAutoBox III Firmware

## New Features of the MicroAutoBox III Firmware

---

### New supported hardware

The MicroAutoBox III firmware supports the following new hardware:

- **DS1521 Bus Board**

The new DS1521 Bus Board is a bus and network board that offers more automotive bus interfaces, such as CAN FD and automotive Ethernet.

For more information, refer to [Features of the DS1521 Bus Board](#) ([MicroAutoBox III Hardware Installation and Configuration](#)).

- **Built-in variant of the MicroAutoBox III Embedded PC**

A MicroAutoBox III Embedded PC is a compact PC system that can be built into the housing of a MicroAutoBox III. The Embedded PC can be used for developing and validating advanced driver assistance, infotainment and telematics systems, or to execute ControlDesk directly on the MicroAutoBox III system.

For more information, refer to [Embedded PC Features](#) ([MicroAutoBox III Embedded PC Hardware Installation and Configuration](#)).

---

### DS1403 Processor Board

The firmware of the DS1403 Processor Board has new features:

**FuSa support** The MicroAutoBox III now supports functional safety monitoring features.

For more information, refer to [Functional Safety](#) ([MicroAutoBox III Hardware Installation and Configuration](#)).

**Logging data** ControlDesk lets you log data on a USB mass storage device that is connected to the MicroAutoBox III. For more information, refer to [General Information on Data Logging](#) ([ControlDesk Measurement and Recording](#)).



# ModelDesk

---

## Where to go from here

## Information in this section

New Features of ModelDesk 5.3.....	99
Migration to ModelDesk 5.3.....	100

---

## New Features of ModelDesk 5.3

---

### Parameterization

The number of significant digits is increased to 15.

---

### Road creation

**OpenDRIVE import** When you import roads in the OpenDRIVE format, the connection points of road elements and junction are connected, if their position and orientation values are identical to the first three decimals. Previously, these values had to be identical to the first 6 or 7 decimals.

---

### Scenario creation

**Lane change maneuver** In addition to lane change maneuvers specified relative to the preferred lane, you can specify maneuvers relative to the center lane or the ASM vehicle. Refer to [How to Specify a Lane Change Maneuver](#) ([📖 ModelDesk Scenario Creation](#)).

**Specifying distances between objects** When you define the distance between the ASM vehicle and a fellow (the longitudinal type is Distance [m]), you can use more optional reference points.

---

### Alias support

You can specify maximum and minimum values for alias variables. These values are available via tool automation and can be used in ModelDesk Testing.

## Migration to ModelDesk 5.3

---

<b>Project migration</b>	As of ModelDesk 5.3, you can migrate only projects created with ModelDesk 4.3 (Release 2016-A) and later.
<b>Platform support</b>	As of ModelDesk 5.3, the DS1005 PPC Board is no longer supported.
<b>Maneuver Editor</b>	With Release 2020-A, maneuvers defined with the Maneuver Editor cannot be used and are removed from the project.
<b>Tool automation for plotting</b>	As of ModelDesk 4.4, ModelDesk has new plotters, and the tool automation for plotting has been changed. To reuse scripts for plotting, you must adapt scripts written for ModelDesk 4.3 and earlier.
<b>Triggering of plots</b>	As of ModelDesk 4.6, plotting is triggered by the simulation model. Previously, ModelDesk triggered plotting. The plots are usually identical but can differ in some cases.

---

**Tip**

To compare measurements, it is useful to use the XY Plotter and use the maneuver time as a signal for the x-axis.

# Model Interface Package for Simulink

## Where to go from here

## Information in this section

New Features of the Model Interface Package for Simulink 4.3..... 101

Migrating to the Model Interface Package for Simulink 4.3..... 102

## New Features of the Model Interface Package for Simulink 4.3

### Support of variable-size signals

The Model Interface Package for Simulink now lets you specify variable-size signals. To specify that a signal is a variable-size signal, you must select the **Variable-size signal** checkbox on the **Signal Configuration** page of the **Data Inport** block dialog. The value specified in the **Width** edit field then indicates the maximum number of elements. Refer to the following illustration:

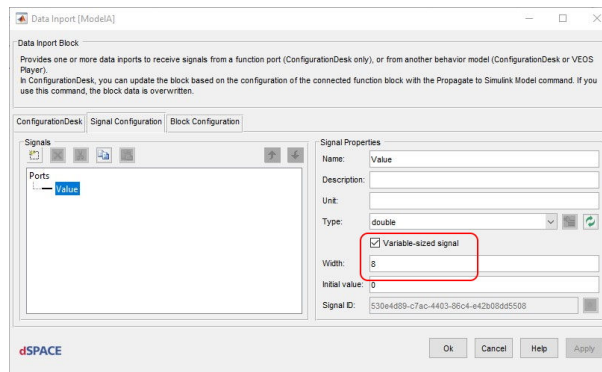

In ConfigurationDesk, you can use variable-size signals for model communication.

**Note**

Variable-size signals are currently not supported by VEOS.

For more information, refer to [Specifying Variable-Size Signals for Model Port Blocks](#) ([Model Interface Package for Simulink - Modeling Guide](#)).

---

**TRC file entries for 64-bit integer variables**

The Model Interface Package for Simulink now creates TRC file entries for 64-bit integer variables in the Simulink model.

**Note**

- To generate TRC file entries for 64-bit integer variables, the SupportLongLong flag must be set in the Simulink model.
- You cannot use signals with the int64/uint64 data type in model port blocks.

## Migrating to the Model Interface Package for Simulink 4.3

---

**Data migration of older versions**

If you open a Simulink model that was created with an earlier version of the Model Interface Package for Simulink, messages for data migration are displayed in the MATLAB Command Window or in the Simulink Diagnostics Viewer. The data of the model is then migrated.

---

**Unsupported new features of MATLAB R2020a**

The Model Interface Package for Simulink does not support the following new feature of MATLAB R2020a:

- MATLAB R2020a provides the half data type as a *tech preview* in Simulink. The 16-bit floating-point data type can be used with the Model Interface Package for Simulink. However, signals of this data type cannot be connected to model port blocks. Variables of this type are not generated into the variable description.

# MotionDesk

## New Features of MotionDesk 4.6

### Where to go from here

### Information in this section

MotionDesk Features (MotionDesk 4.6).....	104
Camera and Fish-Eye Sensor Features (MotionDesk 4.6).....	106
Migrating to MotionDesk 4.6.....	107

## MotionDesk Features (MotionDesk 4.6)

### Material Database Editor

In the MotionDesk Material Database Editor, you can manage the material database:

- Search, filter, and view materials in the dSPACE and custom material database.
- Add and remove materials in the custom material database.
- Add extended properties for the materials in the dSPACE and custom material database.
- Assign extended properties and values for the materials for use with specific sensors.

You can also display the Material ID preview of the 3-D scene by configuring the observer Views.

### Observer navigation

A new observer navigation mode can be selected to move the observer around the 2-D and 3-D scenes using the mouse and mouse buttons. The current zone navigation mode can also be selected.

You can select one of the free or static observers and move along each of the x-, y -and z- axes with the mouse.

- Move upwards and downwards above the scene and forwards, backwards, left, and right through the scene. You can also rotate the observer around an object.
- Move using the mouse and direction keys W, A, S, D keys on the keyboard
- Rotate the observer around an object in the scene in trackball mode. The center point and axis are displayed when moving around the object.
- Unlock fixed observers to change their position and orientation. If you move around the scene with a locked observer it returns to the original position when releasing the mouse button.

For more information, refer to [Overview of the Observer Navigation Mode](#) ( [MotionDesk Scene Animation](#)).



---

### 3-D scene features

The following MotionDesk features for use in the 3-D scene are available:

- 3-D object visibility: Select to hide or display 3-D static or movable object you add to the MotionDesk scene in the observer view and for each of the sensors you add.
- Atmospherics: Select from a range of weather and light conditions for the 3-D scene observer views and for the camera sensors in sensor simulation
- Observer view light and color controls: Enable tone mapping and exposure to improve the detail and light intensities of the objects in the MotionDesk scene. You can also enable pseudo coloring to improve detail in the observer view to analyze hard to see objects in the scene.  
These changes are not applied to the sensor data in the sensor composition window.
- Select **Ctrl + F** to move to an object in the scene that you selected in the **Scene Navigator**. You can also select **Fly to Object** in the context menu.
- Automatic detection of the animated character license for use with sensors in MotionDesk scenes for sensor simulation.
- Automatic detection of the radar and lidar sensor modules for use in MotionDesk scenes for sensor simulation.

---

### Display of ModelDesk routes and markers

Routes and markers that you add in a ModelDesk project can be downloaded to MotionDesk and displayed in the scene. They are not shown in the sensor composition window in sensor simulation.

- Specify if the routes and markers in the ModelDesk project are generated in the MotionDesk scene.
- Default routes and trajectories included in the routes are shown in the **Static Objects** node of the **Scene navigator** and in the 3-D scene.
- Red route markers are displayed in the scene at the start of the route and green route markers are shown at the end of the route.
- Marker shapes added to a road element in ModelDesk are displayed in the **Marker** folder in the **Scene navigator** and in blue in the 3-D scene.

---

### Display screen configuration

You can configure the display screens in the MotionDesk options for sensor simulation and the observer view full screen mode to be displayed independently.

- Parallel use of full screen mode and the sensor simulation composition window on the same screen.
- Run sensor simulation in headless mode without a sensor composition window display.

---

### Tool automation for sensor modifications

You can view and edit the basic properties of each sensor in your sensor simulation architecture using the MotionDesk automation interface.

For example, you can view the name, ID, status, motion data stream, position, and orientation of each sensor.

**Tool automation for ADAS and MicroAutoBox III**

The MotionDesk automation interface is extended with functions for the configuration of the ADAS and MicroAutoBox III platforms.

**Related topics****Basics**

<a href="#">Camera and Fish-Eye Sensor Features (MotionDesk 4.6)</a> .....	106
<a href="#">New Features of Sensor Simulation 1.3</a> .....	135
<a href="#">Working with the Model and Sensor Interface Blockset (📖 MotionDesk Calculating and Streaming Motion Data)</a>	

## Camera and Fish-Eye Sensor Features (MotionDesk 4.6)

**Sensor output settings**

You can configure the camera and fish-eye sensor output features for sensor simulation.

- **Exposure:** You can adjust the image luminance rendered by the SensorSim application by configuring the exposure.
- **Gamma correction:** You can enable and disable gamma correction. The SensorSim application renders the sensor data based on this setting.

**Output the Material ID of the 3-D objects**

The Postprocessing API allows you to use a postprocessing library to access the Material IDs of the 3-D objects in the MotionDesk scene for the camera and fish-eye sensor data output.

The materials of 3-D objects detected by the sensor that match material IDs in the database are displayed in the output.

**Lens distortions**

**Adobe radial distortion polynomials** The SensorSim application adapts camera and fish-eye sensor distortions based on the polynomial configurations specified in the MotionDesk properties. In MotionDesk you can specify higher order polynomial co-efficients than those allowed by the Adobe lens distortion model.

**Lens distortions look-up table** For MotionDesk camera and fish-eye sensors you can specify lens distortions from a look-up table

The lens distortions can be loaded from a look-up table in CSV format. The SensorSim application renders the lens distortions based on the settings.

**Related topics****Basics**

MotionDesk Features (MotionDesk 4.6).....	104
New Features of Sensor Simulation 1.3.....	135
Working with the Model and Sensor Interface Blockset (📖 MotionDesk Calculating and Streaming Motion Data)	

## Migrating to MotionDesk 4.6

**Discontinuation of the DS1005 Processor Board**

As of MotionDesk 4.6, the DS1005 Processor Board is no longer supported.

For more information on common discontinuations, refer to [Discontinuations](#) on page 14.

**Using endless ground plate and horizon**

In MotionDesk 4.0 and earlier, the virtual world of a scene was built using ground plate and dome 3-D objects. If you want to use the endless ground plate and sky, these 3-D objects are obsolete. To use an old scene, delete these objects before you activate the endless ground and sky.

**Using advanced lighting mode**

In advanced lighting mode, the static objects used for domes are not suitable for building the virtual world. Use the endless sky of the environment instead.

**Migrating 3-D custom objects**

If you want to use 3-D custom objects in the VRML2 format that you used in MotionDesk 2.2.1 or earlier, you have to convert the VRML2 files to COLLADA format files. You can convert the files at any time using the **3-D Library Manager**.

**Migrating from MotionDesk version 2.2.1 and earlier**

The current MotionDesk version cannot read MotionDesk experiments in the MDX file format (used in MotionDesk 2.1.6 and earlier) or scenes stored in the ESD format (used in MotionDesk 2.2.1 and earlier). It is therefore not possible to migrate from MotionDesk projects and experiments of these versions.

If you want to use older projects and experiments, you must migrate them using MotionDesk 3.0 up to MotionDesk 3.6 and then open them in the current MotionDesk version.



# Real-Time Testing

---

## Where to go from here

## Information in this section

New Features of Real-Time Testing 4.3..... 109

Migrating to Real-Time Testing 4.3..... 109

---

## New Features of Real-Time Testing 4.3

### New features

Real-Time Testing 2020-A does not have new features.

---

## Migrating to Real-Time Testing 4.3

### Platform support

As of Real-Time Testing 4.3, the DS1005 PPC Board is no longer supported.

### Incompatible BCG files

The BCG files generated with Real-Time Testing 4.0 or earlier cannot be used for Real-Time Testing 4.3. You must create the BCG file of the RTT sequence again.

Only for VEOS: As of Real-Time Testing 4.2 the internal Python interpreter version changed from 2.7.11 to 3.6.4 To use older scripts in the syntax of Python 2.7.11, you must migrate them to the syntax of Python 3.6.4. For more information on migrating Python scripts, refer to <http://www.dspace.com/go/Python36Migration>.

**C# demo scripts**

As of Real-Time Testing 4.2, demo scripts in C# are not longer included. The required internal COM interface is discontinued.

---

**Related topics**

Basics

[Creating and Starting RTT Sequences in Python Scripts](#) (📖 Real-Time Testing Guide)

# RTI/RTI-MP and RTLib

## Where to go from here

## Information in this section

<a href="#">New Features of RTI/RTI-MP and RTLib.....</a>	<a href="#">111</a>
<a href="#">Migration Aspects of RTI/RTI-MP and RTLib.....</a>	<a href="#">112</a>

## New Features of RTI/RTI-MP and RTLib

### New features of RTI/RTI-MP

RTI and RTI-MP have the following new features:

- Support of MATLAB R2020a.
- TRC file entries for 64-bit integer variables in Simulink models.
- New dialogs in RTI and RTI-MP to configure a step size increase of the first simulation steps to avoid task overruns. You can specify coefficients for the step size increase and for the number of steps whose size to increase.
  - RTI: Refer to [Configure Initial Step Size Dialog](#) ([RTI and RTI-MP Implementation Reference](#)).
  - RTI-MP: Refer to [Configure Initial Step Size Dialog \(Multiprocessor Setup Dialog\)](#) ([RTI and RTI-MP Implementation Reference](#)).

Previously, you configured the first simulation steps using compiler options. These compiler options are discontinued with dSPACE Release 2020-A. Refer to [Migration Aspects of RTI/RTI-MP and RTLib](#) on page 112.

### Unsupported new features of MATLAB R2020a

RTI/RTI-MP does not support the following new feature of MATLAB R2020a:

- MATLAB R2020a provides the half data type as a *tech preview* in Simulink. The 16-bit floating-point data type can be used with RTI and RTI-MP. However, signals of this data type cannot be connected to RTI blocks. Variables of this type are not generated into the variable description.

## Migration Aspects of RTI/RTI-MP and RTLib

### Modified features in later MATLAB versions

**Switching to a later MATLAB version** If you install a new MATLAB version, some settings are adopted from previously installed MATLAB versions. To prevent unexpected behavior by the Simulink models when you switch to a later MATLAB version or dSPACE Release, always reset the MATLAB and Simulink preferences to their default values before you start using the models.

If you change the MATLAB version and/or the dSPACE Release, configuration sets stored in a MAT file of an earlier version might cause problems. Therefore, you are recommended to create these configuration sets again when you change the Release version.

#### Note

Configuration sets stored in MAT files using dSPACE Release 2013-B or earlier cannot automatically be migrated to dSPACE Release 2019-B or later with MATLAB R2019b or later. When you load these MAT files, some settings might be lost.

### Discontinued compiler options

Up to and including dSPACE Release 2019-B, you configured the behavior of the initial simulation steps with the `-DFIRST_SIMSTEP_INCREASEMENT` and `-DNUM_INCREASED_SIMSTEPS` compiler options. With dSPACE Release 2020-A, these compiler options are discontinued. If you open or load an RTI model created with Release 2019-B or earlier, the compiler options are automatically migrated to the new coefficients. For RTI-MP models, you also have to open the Multiprocessor Setup block to start the automatic migration.

For new models, you can specify the behavior of the initial simulation steps via the Configure Initial Step Size Dialog and the Configure Initial Step Size Dialog (Multiprocessor Setup Dialog).

### End of software support for discontinued dSPACE hardware

For information on the end of software support for discontinued dSPACE hardware, refer to [Discontinuations](#) on page 14.

**Discontinuation of DS1005 PPC Board** If you want to use a model configured for RTI1005 with another RTI platform, you have to specify the system target file for the new RTI platform, e.g., `rti1007.tlc`. Switching to another platform sets the RTI-specific options to the platform's default values. You must therefore adapt the customized settings on the following pages of the Code Generation dialog manually:

- RTI simulation options
- RTI general build options
- RTI load options
- RTI variable description file options

If you want to use a multiprocessor model, which was configured for DS1005, with another RTI-MP supporting platform, e.g., DS1007, you have to delete the



Multiprocessor Setup block configured for DS1005 and replace it with a new Multiprocessor Setup block. Note, that switching to another RTI-MP platform sets the RTI-MP-specific options to the platform's default values.



# RTI Bypass Blockset

## Where to go from here

## Information in this section

[New Features of the RTI Bypass Blockset 3.14](#)..... 115

[Migrating to RTI Bypass Blockset 3.14](#)..... 116

## New Features of the RTI Bypass Blockset 3.14

### RTI Bypass Blockset

**On-target bypassing on virtual ECUs on MicroAutoBox III** The RTI Bypass Blockset supports on-target, service-based bypassing on virtual ECUs (V-ECUs) on the MicroAutoBox III.

On-target, service-based bypassing on virtual ECUs with the RTI Bypass Blockset is based on the dSPACE Internal Bypassing Service. The V-ECU's A2L file must contain an accordingly adapted `IF_DATA dSPACE_INTERNAL_BYPASS` entry. Refer to [Interface Description Data for Internal Bypassing](#) ( [Interface Description Data Reference](#)).

### RTI Bypass Blockset MATLAB API

**Support of changes made to RTI Bypass Blockset** The RTI Bypass Blockset MATLAB API supports all the changes made to the RTI Bypass Blockset. Refer to the  [RTI Bypass Blockset MATLAB API Reference](#).

## Migrating to RTI Bypass Blockset 3.14

---

### Discontinued support for dSPACE hardware

As of RTI Bypass Blockset 3.14, software support is discontinued for the following dSPACE hardware:

- DCI-GSI1
- DS1005 PPC Board

The remaining example models in the RTI Bypass Demos library are now configured to use the DS1007 PPC Processor Board instead of the DS1005 PPC Board by default.

The demos describing blockset features that previously used the DCI-GSI1, are now configured to use the XCP on UDP-IP interface.

---

### Models containing a DCI-GSI1-based interface

As of dSPACE Release 2020-A, the DCI-GSI1 is no longer supported. As a consequence, the RTI Bypass Blockset no longer supports the following DCI-GSI1-based bypass interface types:

- DCI\_GSI1
- dSPACE\_on\_JTAG\_NEXUS
- dSPACE\_on\_JTAG\_OCDS
- dSPACE\_on\_JTAG\_SDI
- dSPACE\_on\_NBD\_AUD
- dSPACE\_on\_NEXUS\_READI
- cPATCH\_on\_JTAG\_NEXUS
- cPATCH\_on\_JTAG\_OCDS
- cPATCH\_on\_JTAG\_SDI
- cPATCH\_on\_NBD\_AUD
- cPATCH\_on\_NEXUS\_READI

When you open a model with one or more of these DCI-GSI1-based bypass interfaces specified in the imported database files in the RTI Bypass Blockset 3.14 or later, a message informing you about the discontinued support is displayed, and the DCI-GSI1-based interfaces are removed from the Setup block. You can then continue working with the model as follows:

- If you did not select any of the listed interfaces in your model, you can continue working with the model as usual. No migration steps are necessary.
- If you did select one of the above interfaces, you must select a different bypass interface type offered in the Setup block and reconfigure all the affected blocks accordingly.
- If you did select one of the above interfaces but no bypass interface type is offered for selection in the Setup block, you must import another database file with suitable interface definitions (**IF\_DATA** entries) in the Setup block.

For more information, refer to [Migrating Models for DCI-GSI1-Based Interfaces](#) ( [RTI Bypass Blockset Reference](#)).

---

**Working with models from earlier RTI Bypass Blockset versions 3.x and 2.x**

The current Release contains RTI Bypass Blockset 3.14, which is compatible with earlier blockset versions 3.x and 2.x. However, there are some points to note:

- *Working with models from RTI Bypass Blockset 2.5 or earlier*

Data management was changed from the prior RTI Bypass Blockset versions. If you have a Simulink model built with RTI Bypass Blockset 2.5 or earlier and you open it with RTI Bypass Blockset 3.14, the old Data Dictionary file (with the file name extension .dd) is replaced by a new Data Dictionary file (.vdb) using the information stored in the Setup block. This step is performed automatically when you open and close the Setup block dialog by clicking OK, or you open the Read, Write, Upload, or Download block dialog and click Fill Variable Selector on the Variables page.

If you have a model that was saved with RTI Bypass Blockset 3.14 and want to use it with RTI Bypass Blockset 2.5 or earlier, the model's Data Dictionary file required for blockset version 2.5 or earlier (file name extension .dd) is created. This step is performed when you update the A2L files in the Setup block, or you open the Read, Write, Upload, or Download block and click Fill Variable Selector on the Variables page. The Data Dictionary file created under RTI Bypass Blockset 3.14 (.vdb) remains on the disk.

To enable the RTI Bypass Blockset to recreate the Data Dictionary, the database files specified in the Setup block must be unchanged and accessible at the specified location.

- *Working with models from RTI Bypass Blockset 2.6 up to and including RTI Bypass Blockset 3.13*

If a Simulink model was built with RTI Bypass Blockset 2.6 up to RTI Bypass Blockset 3.13, and you open it with RTI Bypass Blockset 3.14, the old Data Dictionary file is replaced by a new Data Dictionary file. However, the new Data Dictionary file cannot be used in earlier RTI Bypass Blockset versions. If you want to reuse the model with RTI Bypass Blockset 2.6 up to and including RTI Bypass Blockset 3.13, you have to create a suitable database in the earlier RTI Bypass Blockset version by reimporting the database files (A2L files) specified in the Setup block.



# RTI CAN MultiMessage Blockset

## Where to go from here

## Information in this section

[New Features of the RTI CAN MultiMessage Blockset 5.4..... 119](#)

[Migrating to RTI CAN MultiMessage Blockset 5.4..... 119](#)

## New Features of the RTI CAN MultiMessage Blockset 5.4

### New supported platform

The RTI CAN MultiMessage Blockset supports SCALEXIO systems with a DS6342 CAN Board. The DS6342 CAN Board provides eight independent CAN/CAN FD channels.

### Support of AUTOSAR ECU Extract

The RTI CAN MultiMessage Blockset now also supports a single AUTOSAR ECU Extract ARXML file as the database file.

Refer to [General Settings Page \(RTICANMM MainBlock\)](#) ( [RTI CAN MultiMessage Blockset Reference](#)).

## Migrating to RTI CAN MultiMessage Blockset 5.4

### Discontinued support for dSPACE hardware

As of RTI CAN MultiMessage Blockset 5.4, software support is discontinued for the following dSPACE hardware:

- DS1005 PPC Board
- MicroAutoBox II variants with the DS1512 I/O Board

---

**Working with models from earlier RTI CAN MultiMessage Blockset versions**

To reuse a model created with an earlier RTI CAN MultiMessage Blockset version, you must update the S-functions for all the RTICANMM blocks and save the model before modifying the CAN configuration.

To create new S-functions for all the RTICANMM blocks in a model in one step, you can perform one of the following actions after opening the model:

- In the MATLAB Command Window, enter `rtimmsu_update('System', bdroot)`.  
For more information on the command and its options, enter `help rtimmsu_update` in the MATLAB Command Window.
- Select the Create S-Function for all CAN Blocks command from the Options menu of the RTICANMM GeneralSetup block.

For more information, refer to [Limitations with RTICANMM](#) ([RTI CAN MultiMessage Blockset Reference](#)).

---

**Compiler messages when using code generated by an RTI CAN MultiMessage Blockset version < 4.0**

If you use code that was generated by an RTI CAN MultiMessage Blockset version < 4.0, several compiler warning messages that contain the phrase `<<argument of type "can_tp1_canChannel *" is incompatible with parameter of type "DsTCanCh">>` will be displayed during the build process of a simulation model. This is due to a modified data type. These warnings can be ignored and disappear after you use the current blockset version to generate the RTICANMM code again.

---

**Using existing checksum algorithms**

Checksum algorithms that were originally developed for an application and contain CAN messages cannot be reused for applications that contain CAN FD messages, because CAN FD includes new message types and longer data fields. Existing checksum algorithms can still be used for applications that contain only classic CAN messages. For CAN FD applications, you must adapt the checksum algorithms.

---

**Changed evaluation of CanFrameBehavior attributes**

In AUTOSAR and FIBEX files, the `CanFrameTxBehavior` and/or `CanFrameRxBehavior` attributes of a message can be defined to specify whether the message is to be treated as a CAN FD message or classic CAN 2.0 message. With the RTI CAN MultiMessage Blockset 5.4, the evaluation and application of these attribute values have changed:

- Up to and including the RTI CAN MultiMessage Blockset 5.3, only the `CanFrameTxBehavior` value was considered. If the `CanFrameTxBehavior` attribute was not set for a message in the database, it was assumed for both directions that it was not a CAN FD message.
- As of RTI CAN MultiMessage Blockset 5.4, the `CanFrameRxBehavior` attribute is also evaluated if required:
  - If the `CanFrameTxBehavior` attribute is defined for a message in the database file, RTICANMM uses this setting for the message on the CAN bus for both directions, i.e., for sending and receiving the message.



- If the `CanFrameTxBehavior` attribute is not defined in the database for a message, RTICANMM uses the message's `CanFrameRxBehavior` setting for sending or receiving the message.



# RTI FPGA Programming Blockset

## Where to go from here

## Information in this section

[New Features of the RTI FPGA Programming Blockset 3.9](#)..... 123

[Migrating to the RTI FPGA Programming Blockset 3.9](#)..... 126

## New Features of the RTI FPGA Programming Blockset 3.9

### Extended Xilinx® support

The RTI FPGA Programming Blockset now supports the following products and versions of the Xilinx design tools:

Xilinx Design Tools Version	MATLAB Version <sup>1)</sup>	Operating System
Vivado 2019.2 <sup>2)</sup>	<ul style="list-style-type: none"> <li>▪ MATLAB R2018b</li> <li>▪ MATLAB R2019a</li> <li>▪ MATLAB R2019b</li> </ul>	Windows operating system that is supported by the RCP and HIL software of the current Release. Refer to <a href="#">Operating System</a> on page 158.

<sup>1)</sup> The Processor Interface sublibrary of the RTI FPGA Programming Blockset also supports MATLAB R2020a.

<sup>2)</sup> The Vivado HL WebPACK Editions of the Xilinx design tools also support the DS2655 (7K160) and DS6601 FPGA base boards. A separate license for the Xilinx System Generator for DSP is required for modeling FPGA applications with the RTI FPGA Programming Blockset.

---

**New I/O Module framework for SCALEXIO systems**

The new *DS6651 Multi-I/O Module* framework now supports the DS6651 Multi-I/O Module.

- 6 x analog input channels
- 6 x analog output channels
- 16 x bidirectional digital signals that can be used for digital I/O and UART communication.

For more information on the *DS6651 Multi-I/O Module* framework, refer to [RTI Block Settings for the DS6651 Multi-I/O Module Framework](#) ([RTI FPGA Programming Blockset - FPGA Interface Reference](#)).

---

**Enhancements to the SCALEXIO FPGA base board frameworks**

General enhancement to the SCALEXIO FPGA board frameworks:

- Support of inter-FPGA communication via IOCNET. Inter-FPGA communication via IOCNET lets you directly exchange data values between FPGA boards.

For more information, refer to [Modeling Inter-FPGA Communication via IOCNET](#) ([RTI FPGA Programming Blockset Guide](#)).

- Digital I/O RTI blocks, except the Digital InOut I/O block, can now be used with an individual clock period to customize the update rate.

A higher update rate increases the time resolution for generating or sampling a digital signal. A higher update rate does not affect the minimum pulse duration or frequency of the digital signal.

For more information, refer to [How to Use Multiple Clock Domains for FPGA Modeling](#) ([RTI FPGA Programming Blockset Guide](#)).

- The model port blocks of the Model Interface Package for Simulink replace the processor interface blocks of the Processor Interface sublibrary.

Model interface blocks are the common blocks for the processor interface in a Simulink model.

For reference information, refer to [Processor Interface Blocks \(MicroAutoBox III, SCALEXIO\)](#) ([RTI FPGA Programming Blockset - Processor Interface Reference](#)).

---

**Enhancements to the DS6601/DS6602 FPGA board frameworks**

The *DS660X\_MGT* framework for the DS6601/DS6602 FPGA boards provide the following enhancements:

- The MGT I/O functions of the framework are renamed to Aurora 64b66b.
- New I/O functions to support 128-bit data values with the Aurora 64b66b link layer protocol.
- New I/O functions to use customized data protocols.

For more information, refer to [Modeling MGT Communication Using a Customized Protocol](#) ([RTI FPGA Programming Blockset Guide](#)).

For more information on the framework, refer to [RTI Block Settings for the DS660X\\_MGT Framework](#) ([RTI FPGA Programming Blockset - FPGA Interface Reference](#)).

The frameworks for the DS6601/DS6602 FPGA boards provide the following enhancements:

- A new Temperature I/O function to read the FPGA die temperature.
- DS6602 only: New ports for the DDR4 access functions to output status information on the initialization.

For more information on the framework, refer to [RTI Block Settings for the DS6602 FPGA Base Board Framework](#) ([RTI FPGA Programming Blockset - FPGA Interface Reference](#)).

---

#### Enhancements to the MicroAutoBox III frameworks

The frameworks for the MicroAutoBox III provide the following enhancements:

- Digital I/O RTI blocks can now be used with an individual clock period to customize the update rate.

A higher update rate increases the time resolution for generating or sampling a digital signal. A higher update rate does not affect the minimum pulse duration or frequency of the digital signal.

For more information, refer to [How to Use Multiple Clock Domains for FPGA Modeling](#) ([RTI FPGA Programming Blockset Guide](#)).

- The model port blocks of the Model Interface Package for Simulink replace the processor interface blocks of the Processor Interface sublibrary.

Model interface blocks are the common blocks for the processor interface in a Simulink model.

For reference information, refer to [Processor Interface Blocks \(MicroAutoBox III, SCALEXIO\)](#) ([RTI FPGA Programming Blockset - Processor Interface Reference](#)).

---

#### Enhancements to the MicroAutoBox II frameworks

Digital I/O RTI blocks can now be used with an individual clock period to customize the update rate.

A higher update rate increases the time resolution for generating or sampling a digital signal. A higher update rate does not affect the minimum pulse duration or frequency of the digital signal.

For more information, refer to [How to Use Multiple Clock Domains for FPGA Modeling](#) ([RTI FPGA Programming Blockset Guide](#)).

---

#### Related topics

##### Basics

[Migrating to the RTI FPGA Programming Blockset 3.9](#)..... 126

## Migrating to the RTI FPGA Programming Blockset 3.9

### Introduction

There are various ways to migrate an existing model, depending on the blockset version used.

### Migrating from RTI FPGA Programming Blockset 1.1 and higher to 3.9

If you implemented an FPGA application with the RTI FPGA Programming Blockset Version 1.1 and later and want to use it with the RTI FPGA Programming Blockset 3.9, the framework automatically updates itself to the current framework version.

The update affects all the subsystems in the model/subsystem. The parameters of the blocks stay the same after updating to the current framework version.

**Display of migrated processor interfaces** With the RTI FPGA Programming Blockset 3.4 ... 3.8, you modeled the processor interface of a SCALEXIO/MicroAutoBox III with processor interface blocks of the Processor Interface sublibrary.

If you migrate a model with processor interface blocks of the Processor Interface sublibrary, the update process migrates these blocks to the model port blocks of the Model Interface Package for Simulink. The following illustrations provide an example.

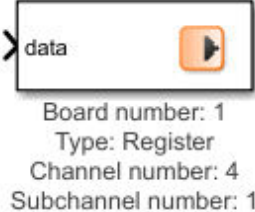
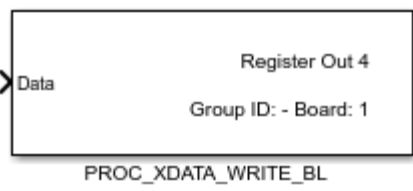
Display After Migration	Display Before Migration
	

### ConfigurationDesk custom functions incompatible with current dSPACE Release

FPGA custom function block types that are not built with the RTI FPGA Programming Blockset 3.9 might be incompatible with the current ConfigurationDesk version.

**FPGA Programming Blockset 3.5 or earlier** With dSPACE Release 2018-B, the angle range handling of the angular processing unit (APU) changed. FPGA custom function blocks that use the APU in the 360° angle range are incompatible if they are built with the FPGA Programming Blockset 3.5 or earlier. To resolve the incompatibility, use the FPGA model/code of the incompatible FPGA custom function block and build a new FPGA custom function block with the RTI FPGA Programming Blockset 3.6 or later. The RTI FPGA Programming Blockset automatically migrates the framework of the FPGA model/code to the current version.

**RTI FPGA Programming Blockset 2.5** An FPGA custom function block generated with RTI FPGA Programming Blockset 2.5 from dSPACE

Release 2013-A and the real-time applications containing the FPGA custom function block are incompatible with the current dSPACE Release. To produce a usable custom function, you have to rebuild the FPGA model by using the current RTI FPGA Blockset.

---

**Using different dSPACE hardware**

Using an FPGA model on different dSPACE hardware requires some model modifications. Refer to [Migrating to Different FPGA Hardware](#) ( [RTI FPGA Programming Blockset Guide](#)).





# RTI LIN MultiMessage Blockset

## Where to go from here

## Information in this section

[New Features of the RTI LIN MultiMessage Blockset 3.4](#)..... 129

[Migrating to RTI LIN MultiMessage Blockset 3.4](#)..... 129

## New Features of the RTI LIN MultiMessage Blockset 3.4

### Support of AUTOSAR ECU Extract

The RTI LIN MultiMessage Blockset now also supports a single AUTOSAR ECU Extract ARXML file as the database file.

Refer to [General Settings Page \(RTILINMM MainSetup\)](#) ( [RTI LIN MultiMessage Blockset Reference](#)).

## Migrating to RTI LIN MultiMessage Blockset 3.4

### Discontinued support for dSPACE hardware

As of RTI LIN MultiMessage Blockset 3.4, software support is discontinued for the following dSPACE hardware:

- DS1005 PPC Board
- MicroAutoBox II variants with the DS1512 I/O Board

### Working with models from earlier RTI LIN MultiMessage Blockset versions

To reuse a model created with an earlier RTI LIN MultiMessage Blockset version, you must update the S-functions for all the RTILINMM blocks and save the model before modifying the LIN configuration.

To create new S-functions for all the RTILINMM blocks in a model in one step, you can perform one of the following actions after opening the model:

- In the MATLAB Command Window, enter `rtimmsu_update('System', bdroot)`.

For more information on the command and its options, enter `help rtimmsu_update` in the MATLAB Command Window.

- Select the Create S-Function for all LIN Blocks command from the Options menu of the RTILINMM GeneralSetup block.

For more information, refer to [Limitations of RTI LIN MultiMessage Blockset](#) ( [RTI LIN MultiMessage Blockset Reference](#)).

# RTI Synchronized Time Base Manager Blockset

## Migrating to the RTI Synchronized Time Base Manager Blockset 1.4

---

**Discontinued support for  
dSPACE hardware**

As of RTI Synchronized Time Base Manager Blockset 1.4, software support is discontinued for the DS1005 PPC Board.



# SCALEXIO Firmware

## New Features of the SCALEXIO Firmware 4.6

---

### New supported hardware

The SCALEXIO firmware supports the following new I/O boards:

- DS6342 CAN Board

The DS6342 CAN Board provides 8 independent CAN/CAN FD channels with a software-configurable termination.

- DS6651 Multi-I/O Module

The DS6651 Multi-I/O Module is an I/O module for the FPGA base boards. It provides the channels for developing and testing a standard three-phase electric drive:

- 6 high-performance analog in channels
  - 6 high-performance analog out channels
  - 16 configurable digital I/O channels (up to 16 single-ended or up to 8 differential)
  - Onboard sensor supply (5 V, 1 A)
  - Onboard signal conditioning for resolver simulation
- 

### Related topics

#### Basics

[DS6342 CAN Board](#) (📖 [SCALEXIO Hardware Installation and Configuration](#))

[DS6651 Multi-I/O Module](#) (📖 [SCALEXIO Hardware Installation and Configuration](#))



# Sensor Simulation

## New Features of Sensor Simulation 1.3

---

### Sensor composition window focus

You can ensure that the sensor composition window remains in focus and is not interrupted by programs, notifications, mouse pointer, screen shutdowns, and screen locks while a simulation is running.

For more information, refer to [SensorSim Application Configuration Settings](#) ( [Sensor Simulation Manual](#)).

---



### SensorSim application

The following features are introduced into the SensorSim application for sensor simulation.

- Radar and lidar sensor module installation check: The SensorSim application renders the data for radar and lidar sensors if the corresponding radar and lidar sensor modules for the release are installed.
- Animated characters license check: The SensorSim application renders the animated characters for all sensor types if the license is installed
- Headless mode: The SensorSim application renders the composition sensor data in the off-screen buffer. The image is not displayed in the sensor composition window. You can select to postprocess the data or write it to the shared memory.
- Atmospherics: The SensorSim application renders the lighting and weather atmospheric conditions that you configure in the MotionDesk scene.
- Simple and advanced lighting: The SensorSim application adjusts the lighting in the scene to reduce the visual differences between the simple and advanced lighting modes. This is also reflected in the MotionDesk observer view.
- SensorSim application logging: The logging of the SensorSim application is extended to include more detailed information.

**Related topics**

**Basics**

Camera and Fish-Eye Sensor Features (MotionDesk 4.6).....	106
MotionDesk Features (MotionDesk 4.6).....	104
 MotionDesk Sensor Simulation Control	
 Sensor Simulation Manual	
 Sensor Simulation Overview	



# SYNECT

---

**Where to go from here****Information in this section**

New Features of SYNECT 2.9.....	138
Migrating to SYNECT 2.9.....	147

## New Features of SYNECT 2.9

### Where to go from here

### Information in this section

<a href="#">New General Features of SYNECT</a> .....	138
Provides an overview of new general SYNECT features.	
<a href="#">OData Support</a> .....	139
The SYNECT server now provides an OData service that let you access data on the server.	
<a href="#">New Features of Test Management</a> .....	143
Provides an overview of the new SYNECT test management features.	
<a href="#">New Features of Workflow Management</a> .....	144
Provides an overview of the new SYNECT workflow management features.	

## New General Features of SYNECT

### OData support

The SYNECT server can now provide an OData service that lets you access data on the server. Refer to [OData Support](#) on page 139.

### Improved view configurations

View configurations let you store the layout of a data grid for a single user or as a shared configuration for all users in the database. A view configuration specifies the displayed columns, the sort and group configuration.

You can now import and export view configurations to share them across databases.

### Improved add-ons

Add-ons let you bundle extensions such as plug-ins, server scripts, data model extensions, etc. in an ADDONZ file for distribution.

You can now distribute the following items with add-ons:

- View configurations for use cases that are supported by an add-on.
- Configuration files, e.g., to provide URLs of servers that are connected by an add-on.

**Improved logging**

You can write logging messages to the Messages pane. The messages also provide severity information, such as Error, Warning, or Info.

You can now also provide information on the sending module.

**Related topics**

Basics

[OData Support..... 139](#)

## OData Support

**Introduction**

The SYNECT server now provides an OData service that let you access data on the server.

**Accessing the SYNECT server**

The OData service provides an alternative way to access data on the SYNECT server.

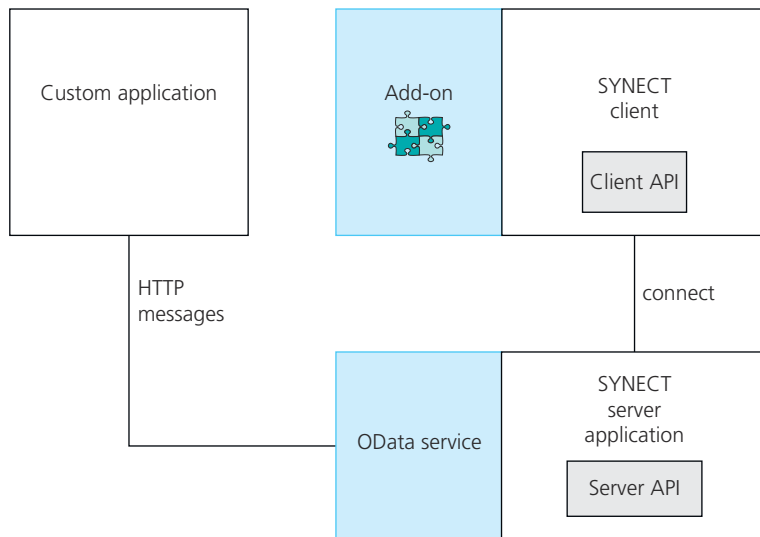

You can access data in the SYNECT database in the following ways:

Method of Data Access	Description
Client-server connection	The SYNECT client is a rich Windows client that provides improved user experience. You can extend the functionality of the client by installing add-ons. The client provides an API for automating the actions that you can perform in its graphical user interface.

Method of Data Access	Description
Server API	The SYNECT server provides an API that lets you implement server scripts that are executed on the server. This lets you work with database items, e.g., to create, edit, or delete them. You can implement custom add-ons that call server scripts via the client API.
OData service	The SYNECT server provides an OData service that lets you implement custom applications that access the SYNECT database via HTTP messages. You can use programming languages such as Python or Java Script for the implementation on the operating system of your choice. The OData service lets you read items, update them, execute server scripts, and execute queries.

### Enabled OData service

The OData service is enabled by default when you configure the SYNECT server application in the SYNECT Server Administrator as shown in the following illustration.

**OData**

Enable:

User:

Password:

Maximum page size:

Mapping JSON path:

The SYNECT Server Administrator connects to the configured Microsoft SQL database with the specified user. The Administrator writes a default mapping of OData entity data model (EDM) types to the SYNECT data model that is required for data access.

You can now access the SYNECT server via the OData service when you operate the server in Microsoft Internet Information Services.

### Provided REST API

The SYNECT server provides the following HTTP-based REST API for access via OData:

Method	Description
GET	SYNECT supports the GET method to retrieve data from the server. You have to specify the data to retrieve in an URL and use operators to get specific data. GET methods return the data as JSON object and provide a status of the operation.
PATCH	SYNECT supports the PATCH method to change existing items. You have to specify an item in the URL by its id and provide the item changes as JSON object in the body of the request. The PATCH method returns the updated item and the status of the operation.

Method	Description
POST	<p>SYNECT supports the POST method to execute queries and server scripts. You have to specify the query or server script to execute in the URL of the method. You can provide parameters as JSON object in the request body.</p> <p>The method returns query and server script results as JSON objects. The method also returns the status of the operation.</p>

You have to provide authentication data in the body of the request. SYNECT supports basic authentication, i.e., SYNECT user name and password, and Windows authentication.

---

### Example access

You can implement the access to the SYNECT server via OData with the `HttpClient` class that the `System.Net.Http` namespace provides for sending HTTP requests and getting response. SYNECT provides a demo script for this.

Example URL:

`https://localhost:443/SYNECTServer/api/synect/v1/testCase`

Response:

```

{
  "@odata.context": "...",
  "value": [
    {
      "id": "a1c42a231ccc43c58fc659bdfb7114015e32a851f0044e6397dd0dd2029e6603",
      "name": "Open command safety-unlocks car",
      "sequenceName": "CentralLockingLibrary.Unlock car",
      "parameters": [
        {
          "name": "Parameters.car_has_remote",
          "description": null,
          "created": "2019-12-20T13:48:23.7Z",
          "id": "074679c7a3274285ab101be9bb2a68fc64ef25e68e6b4e0dbb325fc0f9c46e31",
          "itemtypeid": "074679c7-a327-4285-ab10-1be9bb2a68fc",
          "foreignId": "P1",
          "modified": "2019-12-20T13:48:23.7229018Z",
          "version": "0",
          "releaseComment": null,
          "status": "Draft",
          "value": "1",
          "dataType": "Integer"
        },
        {
          "name": "Parameters.test_info",
          "description": null,
          "created": "2019-12-20T13:48:23.7000001Z",
          "id": "074679c7a3274285ab101be9bb2a68fcd7d77ee6a4b84fc790b9910c3164de59",
          "itemtypeid": "074679c7-a327-4285-ab10-1be9bb2a68fc",
          "foreignId": "P2",
          "modified": "2019-12-20T13:48:23.7239056Z",
          "version": "0",
          "releaseComment": null,
          "status": "Draft",
          "value": "open command",
          "dataType": "String"
        },
        {
          "name": "Parameters.max_unlock_time",
          "description": "Describes the maximum time to unlock the doors in [ms]",
          "created": "2019-12-20T13:48:23.7000002Z",
          "id": "074679c7a3274285ab101be9bb2a68fc267d92f7f6f942a786ad0daa150dd9df",
          "itemtypeid": "074679c7-a327-4285-ab10-1be9bb2a68fc",
          "foreignId": "P3",
          "modified": "2019-12-20T13:48:23.7239056Z",
          "version": "0",
          "releaseComment": null,
          "status": "Draft",
          "value": "550",
          "dataType": "Integer"
        }
      ]
    }
  ]
  ...
}

```

Status:

200 [OK]

**Futher reading**Refer to [Using the OData Service](#) ( SYNECT Guide).

## New Features of Test Management

**Support for teamwork with test developers**

The AutomationDesk add-on now lets you synchronize SYNECT test management projects with custom libraries to support the teamwork of test managers and test developers.

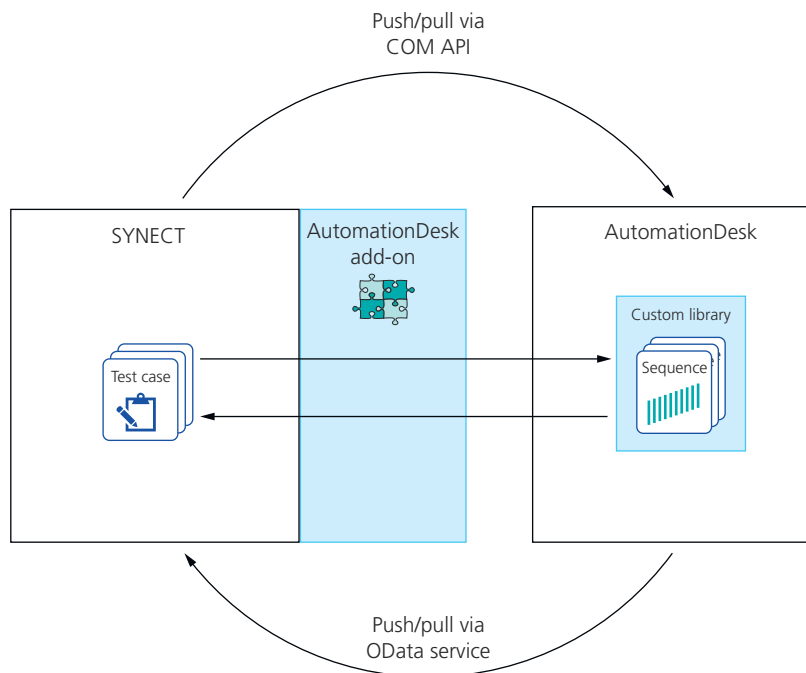



You have the following alternatives to synchronize sequences between SYNECT and AutomationDesk:

- Test managers can synchronize from SYNECT.  
You can pull library changes that were made by test developers to the test cases in SYNECT. You can also push changes that you made in SYNECT to AutomationDesk.  
A local installation of the SYNECT client and AutomationDesk is required.
- Test developers can synchronize from AutomationDesk.  
As a test developer, you implement and maintain sequences in AutomationDesk and change the custom library. You can push the changes you made in a custom library to SYNECT. You can also pull changes from SYNECT to AutomationDesk.

A local installation of AutomationDesk is required. The connection with the SYNECT database is established via the OData service of the SYNECT server. Therefore, a local installation of the SYNECT client is not required for this scenario.

---

**Further reading**

- For more information on the features of the Test Management AutomationDesk Plug-In add-on, refer to [Connecting with AutomationDesk](#) ( SYNECT Guide).
- For more information on the new AutomationDesk features for synchronization, refer to [Using AutomationDesk with SYNECT](#) ( AutomationDesk Basic Practices).

## New Features of Workflow Management

---

**Workflow Management Git CM add-on**

Workflow management now provides the Workflow Management Git CM add-on, which lets you work with Git repositories in SYNECT via the Workflow Management Python API.

**Use case** A typical use case is the continuous integration of a variant-dependent Simulink model in a SYNECT workflow. If you control the version of the model files via a remote Git repository, you can use the Git CM add-on to integrate Git tasks into your workflow, such as cloning the remote repository and pulling files from it. Refer to the following illustration.



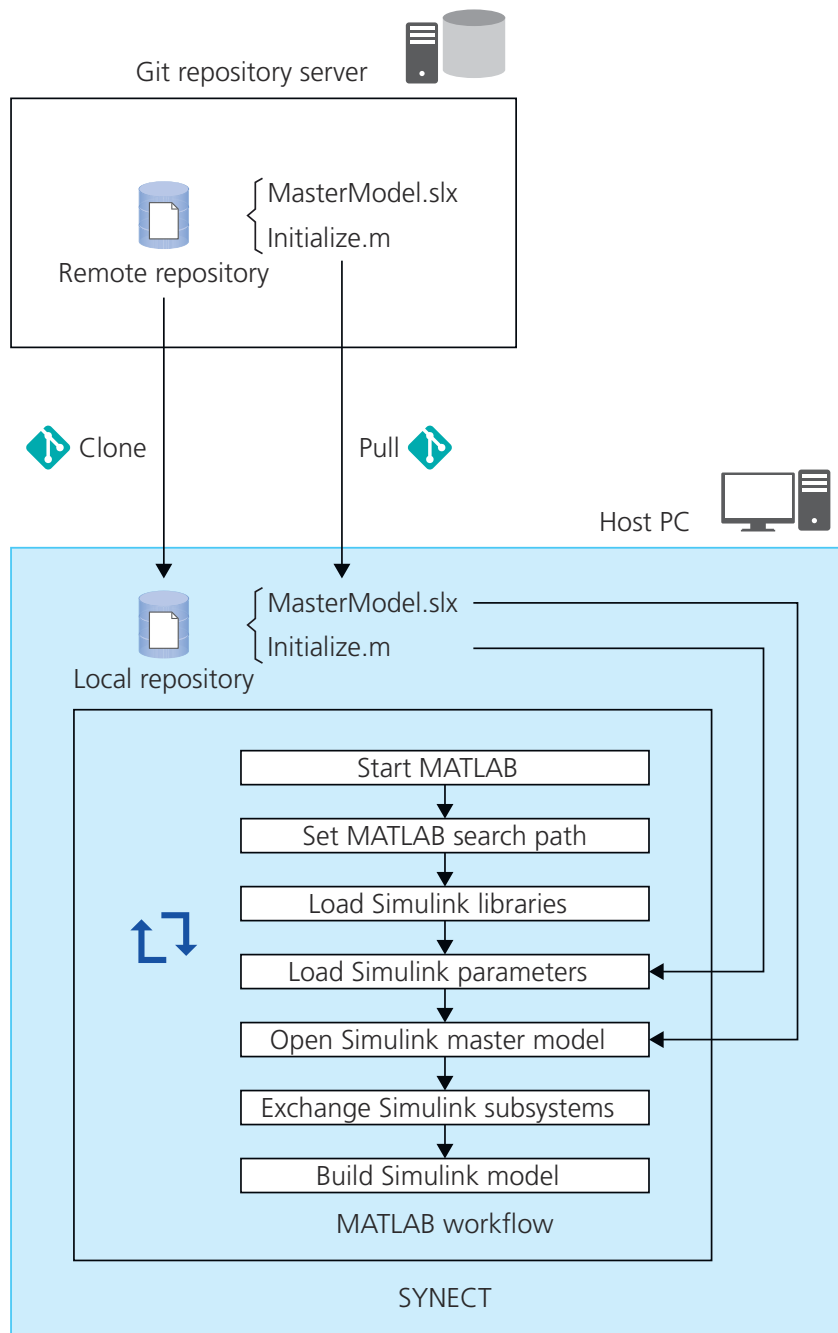

**Git workflow steps and parameters** The Git CM add-on provides Python workflow steps for the basic Git operations clone, stage, commit, push, and pull. You can use workflow management parameters to specify variant-dependent information that is required to perform Git operations, such as file locations or branch names.

**Copying parameter values**

Workflow management has a parameter tree for specifying variant-dependent values for workflows.

You can now copy the Value of parameters.

The Value can be specified in a generic for all variants using macros. This generic is expanded to the RealValue for specific variants. Copying the Value helps you copy parameters to across the tree.

**Support of custom attributes for parameters**

You can now add custom attributes to parameters.

The following illustration shows the Supported custom attribute in the parameter tree:

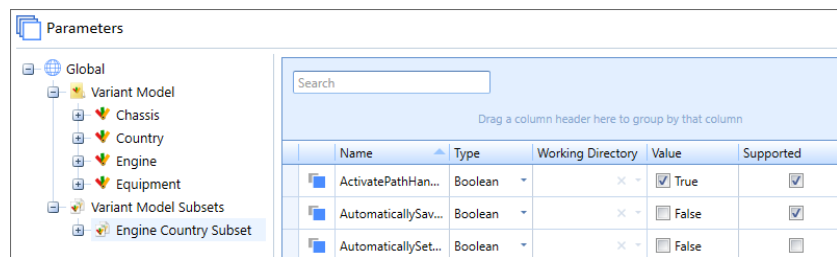

Name	Type	Working Directory	Value	Supported
ActivatePathHan...	Boolean	x	<input checked="" type="checkbox"/> True	<input checked="" type="checkbox"/>
AutomaticallySav...	Boolean	x	<input type="checkbox"/> False	<input checked="" type="checkbox"/>
AutomaticallySet...	Boolean	x	<input type="checkbox"/> False	<input type="checkbox"/>

You can also specify custom attributes for working directories.

The following illustration shows the Custom Attributes page of working directories.

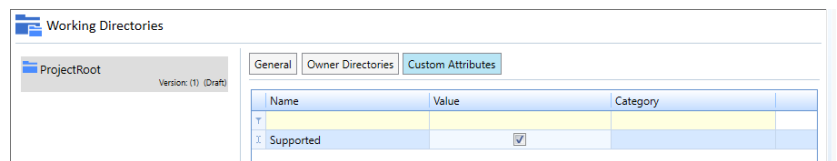

Name	Value	Category
Supported	<input checked="" type="checkbox"/>	

**Further reading**

Refer to [Managing Workflows](#) ( SYNECT Guide).

# Migrating to SYNECT 2.9

## Where to go from here

## Information in this section

<a href="#">Migrating Databases</a> .....	147
To use the data from previous SYNECT versions with SYNECT 2.9, you have to migrate the SYNECT database.	
<a href="#">Migrating from SYNECT 2.8</a> .....	147
Provides information on the points to note when migrating from SYNECT 2.8 to SYNECT 2.9.	
<a href="#">Data Model Changes From SYNECT 2.8 to SYNECT 2.9</a> .....	149
Some parts of the SYNECT data model have been changed from SYNECT 2.8 to SYNECT 2.9.	

## Migrating Databases

### Introduction

To use the data from previous SYNECT versions with SYNECT 2.9, you have to migrate the SYNECT database.

To migrate databases for SYNECT Versions 2.0 - 2.8 to SYNECT 2.9, SYNECT 2.9 provides the Database Migrator.

#### Note

Contact dSPACE Support if you want to migrate SYNECT versions earlier than SYNECT 2.0.

For basic information and instructions on migrating databases, refer to [Migrating Databases from Previous SYNECT Versions](#) ([PDF](#) The SYNECT Server Guide).

## Migrating from SYNECT 2.8

### Migrating ECXML files for the AutomationDesk plug-in

The execute adapter of the AutomationDesk plug-in no longer creates directories named according to the execute time as subdirectories of work or backup directories.

Instead, you can add the `%Started%` variable, which is replaced by the Started attribute value of executions or evaluations, to specified directories. You have to adapt ECXML files of previous SYNECT versions accordingly.

Add the `%Started%` variable to the following properties:

- `WorkDirectory`
- `ReportDirectory`
- `BackupDirectory`

**Further reading** For more information, refer to [AutomationDesk Execute Adapter](#) ([SYNECT Guide](#)).

---

### Changed import behavior of the AutomationDesk plug-in

The AutomationDesk plug-in specifies the `Sequence Name` attribute of test cases and evaluation functions during import to map them to sequences. With this version, the import also maps the folder hierarchy of sequences in a custom library to the `Sequence Name` attribute.

Import with SYNECT versions earlier than SYNECT 2.9:

```
CentralLockingLibrary.Lock car
```

Import with SYNECT 2.9: `CentralLockingLibrary.Tests System.Lock car`

SYNECT identifies sequences by their name because the name must be unique in a custom library. Therefore, you can execute test cases and evaluation functions with SYNECT 2.9 that were imported with SYNECT versions earlier than SYNECT 2.9.

The following applies:

- Import with SYNECT 2.9 updates the `Sequence Name` attribute, including the folder hierarchy.
- The export adapter provides a configuration property that lets you select whether the folder hierarchy must be available when you use the `Push` command to synchronize test cases and evaluation functions with sequences in a custom library. The `AllowMoveSequenceToRoot` property is disabled by default and prevents that sequences without a hierarchy are moved from subfolders to the library root.
- SYNECT prints a warning to the `Messages` pane when you execute sequences without the folder hierarchy in the `Sequence Name` attribute.

**Further reading** For more information, refer to [AutomationDesk Export Adapter](#) ([SYNECT Guide](#)).

---

### Migrating scripts to be used with the Script Sequencer

The Script Sequencer was discontinued with SYNECT 2.9.

dSPACE provides the Workflow Management Script Sequencer Migration add-on, which lets you migrate Python scripts that you implemented for use with the Script Sequencer.

You have to store the following files for migration:

- Export required configurations of the Script Sequencer with a previous SYNECT version, such as SYNECT 2.8.
- Backup script files and the `SEQ.XML` files for referencing them in the Script Sequencer.

The scripts can be migrated for use with workflow steps.

You can install the add-on from the dSPACE Website. It provides user documentation with details of the migration process.

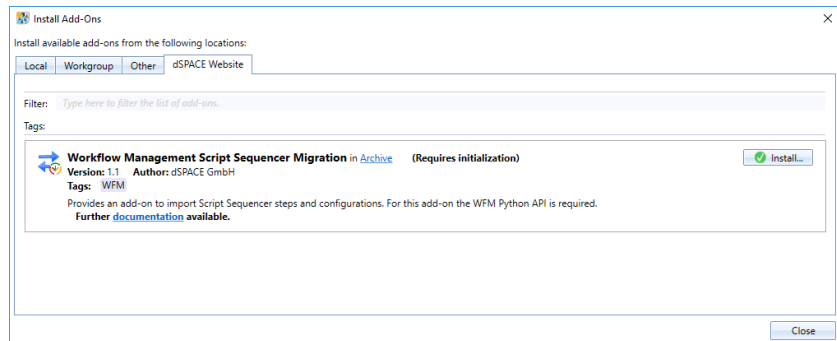

### Migrating view configurations of workflow management parameters

Due to the support of custom attributes, the view configurations of the workflow management parameter tree changed.

When you migrate the SYNECT database to SYNECT 2.9, existing view configurations of the workflow management parameter tree are deleted.

You have to create new view configurations for the parameter tree of workflow management.

## Data Model Changes From SYNECT 2.8 to SYNECT 2.9

### Introduction

Some parts of the SYNECT data model have been changed from SYNECT 2.8 to SYNECT 2.9.

### Deleted item types

No item types were deleted.

### Deleted attributes

No attributes were deleted.

### Deleted reference types

No reference types were deleted.

### New item types

No item types were added.

**New attributes**

The following attributes were added to the SYNECT data model:

Domain	Item Type	Attributes
Variant Management	<a href="#">Variant Base</a> (  <a href="#">SYNECT Data Model Reference</a> )	Variant Path

**New reference types**

No reference types were added.

# VEOS

## Where to go from here

## Information in this section

<a href="#">New Features of VEOS 5.0</a> .....	151
Gives an overview of the new features of VEOS 5.0.	
<a href="#">Compatibility of VEOS 5.0</a> .....	152
Provides information on the compatibility of VEOS 5.0.	
<a href="#">Migrating to VEOS 5.0</a> .....	155
To migrate from VEOS 4.5 to VEOS 5.0, you might have to perform certain migration steps.	

## New Features of VEOS 5.0

### Building offline simulation applications for Linux

You can now build offline simulation applications for execution on a Linux operating system. To this end, the VEOS installation for Windows includes the GCC 5.5 cross compiler.

A VEOS version for Linux is not part of dSPACE Release 2020-A, but will be provided separately.

For an overview of model support features, refer to [Compatibility of VEOS 5.0](#) on page 152.

### Specifying additional code files for the FMU build process

VEOS 5.0 now lets you specify additional, code files for the build process of a Functional Mock-up Unit (FMU). Refer to [Import](#) ([📖 VEOS Manual](#)).

## Compatibility of VEOS 5.0

<b>General compatibility</b>	dSPACE recommends using only software products from the same dSPACE Release. This ensures maximum run-time compatibility.										
<b>Supported compiler versions</b>	For information on supported compiler versions, refer to <a href="#">Basics on Integrating the Simulation System</a> (  <a href="#">VEOS Manual</a> ).										
<b>Supported operating systems</b>	For information on the operating systems supported by VEOS, refer to <a href="#">Operating System</a> on page 158.										
<b>BSC file compatibility</b>	<p>VEOS 5.0 is compatible with bus simulation container (BSC) files created with the Bus Manager of dSPACE Release 2020-A (BSC version 1.8).</p> <ul style="list-style-type: none"> <li>▪ If a BSC file was generated <i>without an SIC file</i>, or <i>with an SIC file that was generated for the dsrt.tlc system target file</i>, you can integrate the BSC file in a VEOS simulation on Windows.</li> <li>▪ If a BSC file was generated <i>with an SIC file that was generated for the dsrt64.tlc system target file</i>, you can integrate the BSC file in a VEOS simulation on Linux.</li> </ul>										
<b>CTLGZ file compatibility</b>	<p>The following table shows the compatibility between VEOS 5.0 and V-ECU implementation (CTLGZ) files:</p> <table border="1"> <thead> <tr> <th>V-ECU Implementations Created With...</th> <th>V-ECU Implementation Version</th> </tr> </thead> <tbody> <tr> <td>dSPACE Release 2020-A: <ul style="list-style-type: none"> <li>▪ SystemDesk 5.4</li> </ul> </td> <td>2.10<sup>1)</sup></td> </tr> <tr> <td>dSPACE Release 2019-B: <ul style="list-style-type: none"> <li>▪ SystemDesk 5.4</li> <li>▪ TargetLink 5.0</li> </ul> </td> <td>2.10<sup>1)</sup></td> </tr> <tr> <td>dSPACE Release 2019-A: <ul style="list-style-type: none"> <li>▪ SystemDesk 5.3</li> </ul> </td> <td>2.9<sup>2)</sup></td> </tr> <tr> <td>dSPACE Release 2018-B: <ul style="list-style-type: none"> <li>▪ SystemDesk 5.2</li> <li>▪ TargetLink 4.4</li> </ul> </td> <td>2.8<sup>2)</sup></td> </tr> </tbody> </table> <p><sup>1)</sup> You can integrate a CTLGZ file of this version in a VEOS simulation on Windows and in a VEOS simulation on Linux.</p> <p><sup>2)</sup> You can integrate a CTLGZ file of this version in a VEOS simulation on Windows, not in a VEOS simulation on Linux.</p>	V-ECU Implementations Created With...	V-ECU Implementation Version	dSPACE Release 2020-A: <ul style="list-style-type: none"> <li>▪ SystemDesk 5.4</li> </ul>	2.10 <sup>1)</sup>	dSPACE Release 2019-B: <ul style="list-style-type: none"> <li>▪ SystemDesk 5.4</li> <li>▪ TargetLink 5.0</li> </ul>	2.10 <sup>1)</sup>	dSPACE Release 2019-A: <ul style="list-style-type: none"> <li>▪ SystemDesk 5.3</li> </ul>	2.9 <sup>2)</sup>	dSPACE Release 2018-B: <ul style="list-style-type: none"> <li>▪ SystemDesk 5.2</li> <li>▪ TargetLink 4.4</li> </ul>	2.8 <sup>2)</sup>
V-ECU Implementations Created With...	V-ECU Implementation Version										
dSPACE Release 2020-A: <ul style="list-style-type: none"> <li>▪ SystemDesk 5.4</li> </ul>	2.10 <sup>1)</sup>										
dSPACE Release 2019-B: <ul style="list-style-type: none"> <li>▪ SystemDesk 5.4</li> <li>▪ TargetLink 5.0</li> </ul>	2.10 <sup>1)</sup>										
dSPACE Release 2019-A: <ul style="list-style-type: none"> <li>▪ SystemDesk 5.3</li> </ul>	2.9 <sup>2)</sup>										
dSPACE Release 2018-B: <ul style="list-style-type: none"> <li>▪ SystemDesk 5.2</li> <li>▪ TargetLink 4.4</li> </ul>	2.8 <sup>2)</sup>										
<b>FMU file compatibility</b>	<ul style="list-style-type: none"> <li>▪ VEOS supports Functional Mock-up Units (FMUs) that comply with the FMI 2.0 standard.</li> </ul>										



- VEOS supports only the *FMI for Co-Simulation interface*, but not the FMI for Model Exchange interface.

You can integrate an FMU file in a VEOS simulation on Windows and in a VEOS simulation on Linux.

For detailed and up-to-date compatibility information on the dSPACE FMI support, refer to:

<http://www.dspace.com/go/FMI-Compatibility>.

### OSA file compatibility

The following table shows the compatibility between VEOS 5.0 and offline simulation application (OSA) files:

OSA Files Created with Products Of ...	OSA Version
dSPACE Release 2020-A	5.0 <sup>1)</sup>
dSPACE Release 2019-B	4.5 <sup>2)</sup>
dSPACE Release 2019-A	4.4 <sup>2)</sup>
dSPACE Release 2018-B	4.3 <sup>2)</sup>

<sup>1)</sup> OSA files created or modified with VEOS 5.0 cannot be loaded in earlier VEOS versions.

<sup>2)</sup> You cannot modify the properties of VPUs contained in an OSA file if you open the OSA file in a later VEOS version than the version with which the OSA file was originally created. However, port and network connections can be edited. As a consequence, it is recommended to rebuild the binary OSA files from existing model implementation container files (CTLGZ, SIC, BSC, FMU) when you migrate from one VEOS version to another.

### SIC file compatibility

The following table shows the compatibility between VEOS 5.0 and Simulink implementation container (SIC) files:

SIC Files Created With ...	SIC Version
dSPACE Release 2020-A: <ul style="list-style-type: none"> <li>▪ Model Interface Package for Simulink 4.3</li> </ul>	1.8 <sup>1), 2)</sup>
dSPACE Release 2019-B: <ul style="list-style-type: none"> <li>▪ Model Interface Package for Simulink 4.2</li> <li>▪ TargetLink 5.0</li> </ul>	1.7 <sup>1), 2)</sup>
dSPACE Release 2019-A: <ul style="list-style-type: none"> <li>▪ Model Interface Package for Simulink 4.1</li> </ul>	1.6 <sup>1), 3)</sup>

SIC Files Created With ...	SIC Version
dSPACE Release 2018-B: <ul style="list-style-type: none"> <li>▪ Model Interface Package for Simulink 4.0</li> <li>▪ TargetLink 4.4</li> </ul>	1.5 <sup>1), 3)</sup>

- 1) If the SIC file is created with a previous dSPACE Release and if the SIC file contains an ASM model, you cannot simulate the model in VEOS 5.0 (dSPACE Release 2020-A). For more information, refer to [Migrating ASM Models](#) (📖 [VEOS Manual](#)).
- 2) If an SIC file of this version was generated for the `dsrt.t1c` system target file, you can integrate it in a VEOS simulation on Windows. If an SIC file of this version was generated for the `dsrt64.t1c` system target file, you can integrate it in a VEOS simulation on Linux. Refer to [How to Generate a Simulink Implementation Container](#) (📖 [Model Interface Package for Simulink - Modeling Guide](#)).
- 3) You can integrate an SIC file of this version in a VEOS simulation on Windows, not in a VEOS simulation on Linux.

### SMC file compatibility

The following table shows the compatibility between VEOS 5.0 and system model container (SMC) files:

SMC Files Created With ...	SMC Version
dSPACE Release 2020-A: <ul style="list-style-type: none"> <li>▪ SYNECT 2.9</li> <li>▪ VEOS 5.0</li> </ul>	1.2
dSPACE Release 2019-B: <ul style="list-style-type: none"> <li>▪ SYNECT 2.8</li> <li>▪ VEOS 4.5</li> </ul>	1.1
dSPACE Release 2019-A: <ul style="list-style-type: none"> <li>▪ SYNECT 2.7</li> <li>▪ VEOS 4.4</li> </ul>	1.1
dSPACE Release 2018-B: <ul style="list-style-type: none"> <li>▪ SYNECT 2.6</li> <li>▪ VEOS 4.3</li> </ul>	1.1

You also have to consider the following compatibility restrictions of the individual container files contained in the SMC file to be imported: If the SMC file contains a container of an unsupported version, VEOS 5.0 imports neither the unsupported container nor the connections to the application process based on the unsupported container.

### Real-Time Testing compatibility

To use RTT in connection with VEOS and ControlDesk, the Real-Time Testing (RTT) version used by the VEOS Simulator that runs the simulation system and the RTT version that is active on the PC must be identical.

The following table shows the VEOS Simulator version and the corresponding RTT version:

VEOS Simulator	RTT Version
... from VEOS 5.0	Real-Time Testing Version 4.3
... from VEOS 4.5	Real-Time Testing Version 4.2

VEOS Simulator	RTT Version
... from VEOS 4.4	Real-Time Testing Version 4.1
... from VEOS 4.3	Real-Time Testing Version 4.0
... from VEOS 4.2	Real-Time Testing Version 3.4
... from VEOS 4.1	Real-Time Testing Version 3.3
... from VEOS 4.0	Real-Time Testing Version 3.2

ControlDesk 7.2 automatically uses the VEOS Simulator of VEOS 5.0. You can therefore use RTT in connection with VEOS and ControlDesk if RTT 4.3 is active on the PC.

### Simulation of adaptive V-ECUs

For compatibility information regarding the simulation of adaptive V-ECUs in VEOS, refer to [Compatibility Requirements for the Simulation of Adaptive V-ECUs](#) ( [VEOS Manual](#)).

### Related topics

#### Basics

[Compatibility Requirements for the Simulation of Adaptive V-ECUs](#) ( [VEOS Manual](#))

## Migrating to VEOS 5.0

### Introduction

To migrate from VEOS 4.5 to VEOS 5.0, you might have to perform certain migration steps.

#### Note

To migrate to VEOS 5.0 from versions earlier than 4.5, you might also have to perform the migration steps of the intervening VEOS versions.

### Changed address range for 64-bit applications

Up to and including VEOS 4.5, the simulation of 64-bit applications was limited to the lower 32-bit address range. As of VEOS 5.0, simulations of 64-bit applications use the entire 64-bit address range.

As a result, if the model implementation to build contains code that uses typecasting of memory addresses to 32 bits, the simulation might lead to unexpected results or crash if you build the model implementation with a 64-bit compiler.

To solve the problem, you have two options:

- Build the model implementation with a 32-bit compiler. This is not supported for Linux operating systems.
- Adapt the code contained in the model implementation to a 64-bit simulation target, then build the model implementation with a 64-bit compiler.

---

### Migrating ASM models

You cannot simulate an ASM model on VEOS if the model is contained in an OSA or SIC file that was created with a dSPACE Release earlier than the one to which your VEOS installation belongs.

To simulate an ASM model that was last saved with a dSPACE Release earlier than the dSPACE Release to which your VEOS version belongs, perform the following steps:

1. Migrate the ASM model to the dSPACE Release to which your VEOS version belongs.

For information on migrating ASM models, refer to [Migrating ASM Models](#) ([📖 ASM User Guide](#)).

2. Generate a Simulink implementation container (SIC) file on the basis of the ASM model by using the *Model Interface Package for Simulink*.

For instructions, refer to [Generating Simulink Implementation Containers](#) ([📖 Model Interface Package for Simulink - Modeling Guide](#)).

3. Import the SIC file to the VEOS Player of your VEOS version.

For instructions, refer to [How to Import Simulink Implementations](#) ([📖 VEOS Manual](#)).

---

### Migrating from prior VEOS versions

To migrate from previous VEOS versions and reuse existing offline simulation applications, you might have to carry out additional migration steps. For more information on the migration steps, refer to [Migrating from Prior Versions of VEOS](#) ([📖 VEOS Manual](#)).

# Compatibility Information

---

## Where to go from here

## Information in this section

Supported MATLAB Releases.....	157
Operating System.....	158
Using dSPACE Software on Virtual Machines (VMs).....	160
Run-Time Compatibility of dSPACE Software.....	164
Limitations for Using Windows Features.....	165

## Supported MATLAB Releases

---

### MATLAB®/Simulink®

Working with various dSPACE products requires that MATLAB is installed on your host PC.

#### Tip

For system requirements of MathWorks® software, refer to <http://www.mathworks.com/support/sysreq.html>.

MATLAB Release...	...Is Supported by dSPACE Release 2020-A					
	RCP and HIL Software <sup>1), 2)</sup>	AutomationDesk 6.3 <sup>3)</sup>	TargetLink 5.0	Model Compare 3.0	dSPACE Python Extensions 3.3 <sup>4)</sup>	XIL API .NET MAPort 2020-A
R2020a	✓ <sup>5)</sup>	✓	–	–	✓	✓
R2019b	✓	✓	✓	✓	✓	✓
R2019a	✓	✓ <sup>6)</sup>	✓	✓ <sup>6)</sup>	✓ <sup>7)</sup>	✓
R2018b	✓	✓	✓	✓	✓	✓
R2018a	–	–	✓	✓	–	–

- <sup>1)</sup> 'RCP and HIL software' is a generic term for a software package containing several dSPACE software products, for example, ASM, RTI, ConfigurationDesk, MotionDesk and ModelDesk. These software products are installed in a common folder.
- <sup>2)</sup> MATLAB/Simulink Student Suite does not support Automotive Simulation Models (ASM).
- <sup>3)</sup> The AutomationDesk MATLAB Access Library requires MATLAB.
- <sup>4)</sup> matlplib2 of dSPACE Python Extensions requires MATLAB.
- <sup>5)</sup> R2020a is not supported by the RTI FPGA Programming Blockset – FPGA Interface.
- <sup>6)</sup> R2019a is only supported by Model Compare and the MATLAB Access Library in AutomationDesk if at least R2019a Update 5 is used.
- <sup>7)</sup> R2019a is only supported by the matlplib2 if at least R2019a Update 5 is used.

For up-to-date information on additional MATLAB releases that can be used in combination with dSPACE software, refer to <http://www.dspace.com/go/MATLABCompatibility>.

## Operating System

### Operating system on host PC

The dSPACE products of dSPACE Release 2020-A support the following operating systems:

- The following editions, channels, and servicing options of Windows 10:
  - Windows 10 Professional, Education, and Enterprise (64-bit versions)

The Windows 10 Home, Mobile, and Windows 10 S editions are not supported.

- Long-Term Servicing Branch: LTSB 2016
- Long-Term Servicing Channel: LTSC 2019
- Semi Annual Channel (formerly known as Current Branch (CB)): The compatibility statement of Microsoft applies. This means that newer versions released in this channel should be compatible with all previous versions. dSPACE used the 1903 version of the Semi Annual Channel for testing.
- Windows Server 2016 Standard with Desktop Experience  
Only the listed edition is supported. The Windows Server 2016 Datacenter, Essentials, MultiPoint Premium Server editions are not supported.

Some limitations apply when you use dSPACE software in conjunction with features of Windows. Refer to [Limitations for Using Windows Features](#) on page 165.

---

#### Using MicroAutoBox Embedded PC as host PC

ControlDesk can also be installed on:

- MicroAutoBox Embedded PC 6th Gen. Intel® Core™ i7-6822EQ Processor, running on Microsoft® Windows® 10 IOT Enterprise, LTSB 2016, 64-bit version
- MicroAutoBox III Embedded PC, running on Microsoft® Windows® 10 IoT Enterprise LTSB 2019, 64-bit version

---

#### Operating system on SYNECT server

The SYNECT server supports the following operating systems:

- The same operating systems as listed above for all dSPACE products of dSPACE Release 2020-A.
- Windows Server 2012, Windows Server 2012A
- Windows Server 2019 Standard with Desktop Experience, SAC

---

#### Operating system on server for floating network licenses

If you purchased floating network licenses, you have to specify one of the network PCs as a license server. Every PC with CodeMeter Runtime software can be used as a license server.

**Valid for servers without dSPACE software** dSPACE tests license servers only with Microsoft Windows operating systems in combination with protected dSPACE software.

##### Note

Non-Windows operating systems, such as Ubuntu Linux, are not tested. You can use them at your own risk. dSPACE does not provide support in this case.

**Valid for servers with dSPACE Installation Manager** dSPACE Installation Manager supports the same operating systems as the other dSPACE software products described above.

## Allowing communication

**Installing of additional firewall rules** Additional Windows firewall rules are installed during the installation of various dSPACE software products. For example, one rule allows communication with a dSPACE expansion box, such as AutoBox. Another rule allows MotionDesk to receive motion data from a network channel. These example rules are created by the following commands:

- `netsh advfirewall firewall add rule name="dSPACE Net Service" service=any dir=in action=allow profile=any protocol=icmpv4:0, any description="Allow the dSPACE Net Service to connect to a dSPACE expansion box via network."`
- `netsh advfirewall firewall add rule name="dSPACE MotionDesk" program=<main installation path>\dSPACE\CPHIL2020-A\MotionDesk\Bin\MotionDesk.exe" dir=in action=allow profile=any description="Allow dSPACE MotionDesk to receive motion data via network."`

**Required open TCP/IP network ports** If you are using third-party firewall software on your host PC, ensure that the TCP/IP communication of dSPACE software is not blocked:

- VEOS requires the following open TCP/IP network ports: 111 (TCP and UDP), 3702 (UDP), 7214 (TCP and TCP6), 8090 (TCP), 9923 (UDP), 15000 (UDP), 49152 ... 65535 (TCP, TCP6 and UDP)
- dSPACE Installation Manager and CodeMeter licensing software require the following open TCP/IP network ports:
  - 22350 (TCP and UDP) for communication in a LAN network (if not changed from the default setting).
  - 22352 (TCP and UDP): To access CodeMeter WebAdmin via http.
  - 22353 (TCP and UDP): To access CodeMeter WebAdmin via https.
- dSPACE Help requires an open TCP/IP network port for interprocess communication between its components. The default port number is 11000. If this port number is already being used, another free port is used automatically. The related processes can be identified via the following prefixes: `HelpApsLayer<xxx>`, `HelpInstaller<xxx>`.

## Using dSPACE Software on Virtual Machines (VMs)

### Introduction

As of dSPACE Release 2019-A, you can operate several dSPACE products installed on virtual machines. However, some dSPACE products support VMs only with limitations, and other dSPACE products cannot be operated on VMs at all.



**Usage restrictions****Note**

The dSPACE End User License Agreement (EULA) prohibits:

- Using a virtual machine for circumventing license protection mechanisms, for multiple use of an acquired license or for use outside the use determined by the license type.
- Accessing dSPACE software via Internet or network applications (e.g., Citrix, Microsoft Remote Desktop or other terminal/device servers) or to grant such access to third parties.

If you have any questions or encounter any problems, contact dSPACE Support ([www.dspace.com/go/supportrequest](http://www.dspace.com/go/supportrequest)).

**Recommended virtual machine software**

dSPACE tests the functionality of dSPACE software products with current VMware products and VM hardware compatibility version 10 and version 13.

You can use Windows, Linux, or macOS® as the host operating system.

**Support of dSPACE software on virtual machines****Note**

The following table shows the compatibility for all dSPACE products. For products that support VMs with limitations, the known limitations are listed. For these products, further limitations might apply depending on the use case.

Product	Full Support	Support with Known Limitations	No Support
ASM	✓	—	—
AutomationDesk	—	✓ Known limitations: <ul style="list-style-type: none"> <li>▪ Access to DS1006 modular systems via dSPACE link boards is not possible.</li> <li>▪ Access to DS1006 modular systems via Ethernet connection and slot CPU: Communication and therefore performance is very low.</li> <li>▪ Access to DS1104 R&amp;D Controller Boards is not possible.</li> </ul>	—
Bus Manager	✓	—	—
ConfigurationDesk - Configuration Version	✓	—	—
ConfigurationDesk - Implementation Version	✓	—	—
Container Manager	✓	—	—

Product	Full Support	Support with Known Limitations	No Support
ControlDesk	—	✓ Known limitations: <ul style="list-style-type: none"> <li>▪ Access to DS1006 modular systems via dSPACE link boards is not possible.</li> <li>▪ Access to DS1006 modular systems via Ethernet connection and slot CPU: Communication and therefore performance is very low.</li> <li>▪ Access to DS1104 R&amp;D Controller Boards is not possible.</li> </ul>	—
Data Dictionary Manager	✓	—	—
DCI-GSI Configuration Package	✓	—	—
dSPACE Installation Manager	✓	—	—
ECU Flash Programming Tool	✓	—	—
ECU Interface Base Package	✓	—	—
ECU bypassing target compiler	✓	—	—
Failure Simulation Package	—	✓ Supported only in combination with the VEOS platform. Combinations with other platforms are not tested and therefore not released for use on VMs.	—
Firmware Archives	—	✓ Known limitations: <ul style="list-style-type: none"> <li>▪ Access to DS1006 modular systems via dSPACE link boards is not possible.</li> <li>▪ Access to DS1006 modular systems via Ethernet connection and slot CPU: Communication and therefore performance is very low.</li> <li>▪ Access to DS1104 R&amp;D Controller Boards is not possible.</li> </ul>	—
Firmware Manager			
FlexRay Configuration Tool	✓	—	—
Model Compare	✓	—	—
ModelDesk	—	✓ Known limitations: <ul style="list-style-type: none"> <li>▪ The Traffic Object Manager cannot show custom sensor points in the preview.</li> <li>▪ Plotting occasionally does not start if a start trigger is used.</li> </ul>	—
Model Interface Package for Simulink	✓	—	—
MotionDesk	—	—	✓ <sup>1)</sup>
Platform API Package	—	✓ Known limitations: <ul style="list-style-type: none"> <li>▪ Access to DS1006 modular systems via dSPACE link boards is not possible.</li> <li>▪ Access to DS1006 modular systems via Ethernet connection and slot CPU: Communication and therefore performance is very low.</li> <li>▪ Access to DS1104 R&amp;D Controller Boards is not possible.</li> </ul>	—
Real-Time Testing	—	✓ Known limitations: <ul style="list-style-type: none"> <li>▪ Access to DS1006 modular systems via dSPACE link boards is not possible.</li> <li>▪ Access to DS1006 modular systems via Ethernet connection and slot CPU: Communication and therefore performance is very low.</li> <li>▪ Access to DS1104 R&amp;D Controller Boards is not possible.</li> </ul>	—

Product	Full Support	Support with Known Limitations	No Support
RTI Blocksets (Real-Time Interface)	—	✓ Known limitations: <ul style="list-style-type: none"> <li>▪ Access to DS1006 modular systems via dSPACE link boards is not possible.</li> <li>▪ Access to DS1006 modular systems via Ethernet connection and slot CPU: Communication and therefore the performance is very low.</li> <li>▪ Access to DS1104 R&amp;D Controller Boards is not possible.</li> </ul>	—
Sensor Simulation	—	—	✓ <sup>1)</sup>
SYNECT	✓	—	—
SYNECT Server	✓	—	—
SYNECT License Server	✓	—	—
SystemDesk	✓	—	—
TargetLink	✓	—	—
VEOS	✓ <sup>2)</sup>	—	—

<sup>1)</sup> VMs do not fulfill the requirements for graphics adapters.

<sup>2)</sup> If you want to simulate adaptive AUTOSAR V-ECUs, refer to [Compatibility Requirements for the Simulation of Adaptive V-ECUs](#) ([📖 VEOS Manual](#)).

### Required knowledge for setting up a virtual machine

To set up a virtual machine, you must have knowledge about the technology of VMs.

In virtual environments, significantly higher latencies and lower network performance (network throughput) must be expected compared to physical PCs. dSPACE has no influence on this.

**Using virtual machines in parallel** If you use multiple VMs simultaneously on one PC, sharing of host resources such as CPU, network and disk I/O bandwidth can cause timing issues. dSPACE recommends to use a physical PC if high performance is required by an application.

### Using the 'Revert to snapshot' feature

#### NOTICE

#### Using the 'Revert to snapshot' feature causes invalid licenses.

If you use the 'Revert to snapshot' feature in a VM, all software-based CmContainers on your PC (dSPACE Activation Container and/or dSPACE Borrow Container) become invalid and the contained licenses are lost. This is not the case if the license information is stored on CmDongles.

- Do not use the 'Revert to snapshot' feature for VMs containing software-based CmContainers with activated licenses.

### Using a virtual machine on the host PC

**System requirements** PCs that host virtual machines with dSPACE software, must meet at least the requirements listed in [Appendix: System Requirements](#) ([📖 Installing dSPACE Software](#)). You are recommended to use a PC with more

resources so that the software runs smoothly on a VM, because the VM software itself uses up some of the resources:

- The CPU speed and RAM size must be sufficient to run the operating system and the software on the host PC as well as the guest operating system and the application software on the VM.
- You also require sufficient free disk space to install the VM software and the software you want to run, just as you would if you were installing it directly on your PC.

**Connecting dongle-based devices** If you use dongle-based single-user licenses to use dSPACE software, you first have to connect your CmDongle to the host PC. Then you have to connect the WIBU-Systems CodeMeter-Stick device to the virtual machine on the host PC. For instructions, refer to the documentation of the VM software you use.

**Using floating network licenses** If you use floating network licences, the virtual machine requires access to the dSPACE License Server. For further instructions, refer to [How to Set up a Connection Between Client and Server](#) ([📖 Working with CodeMeter Licensing Technology](#)).

**Optimal display of dSPACE Help** For an optimal display of the content in dSPACE Help, you have to activate the ClearType setting in the VM (= default setting).

You can access this setting via the Windows Start menu (Start – Control Panel – Appearance and Personalization – Display – Adjust ClearType text).

## Run-Time Compatibility of dSPACE Software

### Definition

Run-time compatibility means that:

- dSPACE products can be used in parallel after software installation, even if they are installed in different folders.
- dSPACE products without interaction can run independently of each other.

### Compatibility of products in dSPACE Release 2020-A

dSPACE recommends using only software products from the same dSPACE Release. This ensures maximum run-time compatibility.

Observe the following points:

- Limitations regarding run-time compatibility in the dSPACE tool chain might occur if products from different dSPACE Releases are used together. If dSPACE products interact directly (through automation interfaces) or indirectly (through common file types like A2L), limitations might apply. For minor limitations, refer to the relevant product documentation. The major limitations are described in the following. In rare cases, an additional patch must be installed for a product to achieve run-time compatibility. For more information on the patch and whether a patch is required, refer to <http://www.dspace.com/go/CompPatch>.

- RCP and HIL software products (of Release 2020-A) cannot be used in combination with RCP and HIL software products from earlier dSPACE Releases.

**Major limitation for working with a SCALEXIO system and with MicroAutoBox III** The products for working with a SCALEXIO system and with MicroAutoBox III must be compatible. This is guaranteed only for products delivered with the same dSPACE Release. Contact dSPACE for more information.

**Compatibility of real-time applications loaded to a DS1006, DS1104 or MicroAutoBox II platform** If a real-time application is loaded to one of these platforms with a software product of dSPACE Release 2016-B or later, software products of dSPACE Release 2016-A (and earlier) do not detect that the loaded real-time application is the same as the real-time application stored on your host PC. In this case, you cannot work with the related software product without restrictions.

This also applies if you load a real-time application with a software product of dSPACE Release 2016-A or earlier and use software products of dSPACE Release 2016-B or later, for example, for experimenting.

---

**Combining dSPACE products from earlier Releases**

For more information and notes on the combined use of different products from and with earlier Releases, refer to [http://www.dspace.com/go/ds\\_sw\\_combi](http://www.dspace.com/go/ds_sw_combi).

## Limitations for Using Windows Features

---

**Motivation** Some limitations apply to using dSPACE software in conjunction with features of Windows.

**Fast user switching not supported** dSPACE software does not support the fast user switching feature of Windows.

**Closing dSPACE software before PC shutdown** The shutdown process of Windows operating systems might cause some required processes to be aborted although they are still being used by dSPACE software. To avoid a loss of data, it is recommended to close the dSPACE software manually before shutting down the PC.

**User Account Control** It is recommended to disable the Windows User Account Control (UAC) during the installation of dSPACE software. If you cannot disable UAC, note the following Windows behavior: If UAC is enabled, the setup programs use the administrator account instead of the user account. Therefore, it is important that the administrator account has access to the required drives, particularly the required network drives.

**USB devices**

If you connect dSPACE USB devices that use cables with optoisolation to the PC for the first time, there might be a message that the device driver software was not installed successfully. However, the dSPACE device will work properly later on.

**Using 4K monitors**

The following dSPACE software products have limitations for working with 4K monitors:

- SYNECT: If you use 4K monitors, the SYNECT graphical user interface might not be displayed properly in some cases, but this does not cause functional limitations.
- Real-Time Testing: The Real-Time Test Manager, the user interface for handling RTT sequences, does not support working with 4K monitors.
- FlexRay Configuration Package: The FlexRay Configuration Tool does not support working with 4K monitors.

**FIPS support**

dSPACE software was not developed for or tested against the FIPS PUB 140-2 U.S. government computer security standard (Security Requirements for Cryptographic Modules). For more information on FIPS, refer to <https://technet.microsoft.com/en-us/library/security/cc750357.aspx>.

**Long paths**

dSPACE software does not support the long path syntax of the Windows API. If a path that exceeds 260 characters is used directly or indirectly, the behavior of the dSPACE software is not defined.

**Enabling Windows 8dot3name creation option**

**Note**

It is strongly recommended that the Windows 8dot3name creation option is enabled for all drives (drives used for installation and drives used for work) before you install third-party software, such as MATLAB®/Simulink®, and the dSPACE software.

If the option is disabled during software installation, serious errors can occur when you run the dSPACE software. For example, the build process might be aborted. To repair an installation that was installed while the 8dot3name creation option was disabled, you have to install dSPACE software and required third-party software again.

For instructions on checking the setting and enabling the option, refer to <http://www.dspace.com/faq?346> or to the Microsoft Windows documentation.

**Settings in Windows for user locale and system locale must match**

MATLAB reads the user locale and system locale settings that are specified in Windows operating systems. The user locale and the system locale must match. If these settings are not the same, the system might not behave as expected when working with MATLAB and dSPACE software.

For instructions on checking and changing the settings, refer to [https://www.mathworks.com/help/matlab/matlab\\_env/setting-locale-on-windows-platforms.html?s\\_tid=gn\\_loc\\_drop](https://www.mathworks.com/help/matlab/matlab_env/setting-locale-on-windows-platforms.html?s_tid=gn_loc_drop).

This affects all MATLAB versions and all Windows operating systems, that are supported by dSPACE.

---

**Valid for Windows 10:  
Microsoft .NET Framework 3.5  
feature must be enabled**

The Microsoft .NET Framework 3.5 feature must be installed and enabled. This is required for using client programs and libraries built with .NET Runtime 2.0. If the Microsoft .NET Framework 3.5 is not enabled, the dSPACE software installation is interrupted and an error message is displayed.

With dSPACE Release 2020-B, dSPACE will discontinue the support for client programs and libraries built with .NET Runtime 2.0. This applies to any C#-based programs using the provided interfaces (APIs) for COM automation and for dSPACE Installation Manager. Applications using these interfaces have to use at least .NET Runtime 4.0.





**A**

- ASM Base InCylinder Blockset
  - migration 33
- ASM blocksets
  - migration 32
- ASM Diesel Engine Blockset
  - migration 35
  - new features 34
- ASM Diesel Exhaust Blockset
  - migration 37
- ASM Diesel InCylinder Blockset
  - migration 38
- ASM Drivetrain Basic Blockset
  - migration 39
- ASM Electric Components Blockset
  - migration 40
  - new features 40
- ASM Engine Gasoline Basic Blockset
  - migration 44
- ASM Engine Gasoline Blockset
  - migration 46
  - new features 45
- ASM Environment Blockset
  - migration 42
  - new features 42
- ASM Gasoline InCylinder Blockset
  - migration 48
- ASM Traffic Blockset
  - migration 50
  - new features 49
- ASM Utils
  - new features 51
- ASM Vehicle Dynamics Blockset
  - migration 52
  - new features 52
- AutomationDesk
  - migration 28
  - new features 27

**B**

- Bus Manager (stand-alone)
  - new features 53
- Bus Manager in ConfigurationDesk
  - new features 63

**C**

- Common Program Data folder 10
- CommonProgramDataFolder 10
- ControlDesk
  - migration 77
  - new features 70

**D**

- DCI Configuration Tool
  - migration 82
  - new features 81
- discontinuation 14
  - hardware 14

- planned (hardware) 15
- planned (software) 15
- software 14
  - software support 14
- Documents folder 10
- DocumentsFolder 10
- dSPACE ECU Flash Programming Tool
  - new features 83
- dSPACE FlexRay Configuration Package
  - migration 86
  - new features 85
- dSPACE XIL API
  - migration 89
  - new features 89

**E**

- ECU Interface Manager
  - migration 92
  - new features 91

**F**

- Firmware Manager
  - new features 95

**G**

- general enhancements and changes 11

**H**

- host PC software
  - MATLAB 157
  - operating system 158

**K**

- key features 18

**L**

- limitations for using Windows features 165
- Local Program Data folder 10
- LocalProgramDataFolder 10

**M**

- MATLAB
  - requirements 157
  - supported releases 157
- MicroAutoBox III firmware
  - new features 97
- migration
  - ASM Base InCylinder Blockset 33
  - ASM blocksets 32
  - ASM Diesel Engine Blockset 35
  - ASM Diesel Exhaust Blockset 37
  - ASM Diesel InCylinder Blockset 38
  - ASM Drivetrain Basic Blockset 39
  - ASM Electric Components Blockset 40
  - ASM Engine Gasoline Basic Blockset 44
  - ASM Engine Gasoline Blockset 46
  - ASM Environment Blockset 42

- ASM Gasoline InCylinder Blockset 48
- ASM Traffic Blockset 50
- ASM Vehicle Dynamics Blockset 52
- AutomationDesk 28
- ControlDesk 77
- DCI Configuration Tool 82
- dSPACE FlexRay Configuration Package 86
- dSPACE XIL API 89
- ECU Interface Manager 92
- ModelDesk 100
- MotionDesk 107
- Real-Time Testing 109
- RTI 112
  - RTI Bypass Blockset 116
  - RTI CAN MultiMessage Blockset 119
  - RTI FPGA Programming Blockset 126
  - RTI LIN MultiMessage Blockset 129
  - RTI Synchronized Time Base Manager Blockset 131
- ModelDesk
  - migration 100
  - new features 99
- MotionDesk
  - migration 107
  - new features 104, 106

**N**

- new features
  - ASM Diesel Engine Blockset 34
  - ASM Electric Components Blockset 40
  - ASM Engine Gasoline Blockset 45
  - ASM Environment Blockset 42
  - ASM Traffic Blockset 49
  - ASM Utils 51
  - ASM Vehicle Dynamics Blockset 52
  - AutomationDesk 27
  - Bus Manager (stand-alone) 53
  - Bus Manager in ConfigurationDesk 63
  - ControlDesk 70
  - DCI Configuration Tool 81
  - dSPACE ECU Flash Programming Tool 83
  - dSPACE FlexRay Configuration Package 85
  - dSPACE XIL API 89
  - ECU Interface Manager 91
  - Firmware Manager 95
  - MicroAutoBox III firmware 97
  - ModelDesk 99
  - MotionDesk 104, 106
  - Real-Time Testing 109
  - RTI Bypass Blockset 115
  - RTI CAN MultiMessage Blockset 119
  - RTI FPGA Programming Blockset 123
  - RTI LIN MultiMessage Blockset 129
  - RTI/RTI-MP 111
  - RTLib 111
  - SCALEXIO firmware 133
  - Sensor Simulation 135
  - test management 143
  - VEOS 151
    - workflow management 144
- new general features

SYNECT 138  
new hardware 11

**P**

product overview 16  
Python distribution 12

**R**

Real-Time Testing  
  migration 109  
  new features 109  
requirements  
  host PC software  
    MATLAB 157  
    operating system 158  
RTI Bypass Blockset  
  migration 116  
  new features 115  
RTI CAN MultiMessage Blockset  
  migration 119  
  new features 119  
RTI FPGA Programming Blockset  
  migration 126  
  new features 123  
RTI LIN MultiMessage Blockset  
  migration 129  
  new features 129  
RTI Synchronized Time Base Manager Blockset  
  migration 131  
RTI/RTI-MP  
  new features 111  
  unsupported MATLAB features (R2020a) 111  
RTLib  
  new features 111

**S**

SCALEXIO firmware  
  new features 133  
Sensor Simulation  
  new features 135  
supported MATLAB releases 157  
SYNECT  
  new general features 138  
system requirements  
  operating system 158

**T**

test management  
  new features 143

**U**

unsupported MATLAB features (R2020a)  
  RTI/RTI-MP 111

**V**

VEOS  
  new features 151  
version history 16

**W**

Windows  
  limitations 165  
workflow management  
  new features 144